

Datasheet

Butterfly valve

MTV/MTVF/MTVL

Si-205 EN

Edition: 2020-09

- Advanced triple eccentric design
- Designed for control and shut-off applications
- Designed for applications up to 350° C (662 °F)
- Tightness class in accordance with EN 60534-4 Class V as standard
- Solid seat made of stainless steel
- Wafer design (Mounted between flanges) alt. lugged and flanged design

Options

- Fire safe
- PTFE seat
- High temperature applications up to 550° C (1022 °F)



Type MTV:	Wafer design
Type MTVF:	Flanged design
TYPE MTVL:	Lugged design
Nominal pressure:	PN 10-25
Nominal size:	DN80 - 500 MTV DN80 - 500 MTVF DN80 - 350 MTVL
Material:	Stainless steel, Titanium



Copyright

The copyright on this installation and maintenance datasheet is held by SOMAS Instrument AB. The instructions and drawings contained may not be fully or partially copied, distributed or used in any unauthorized way for competitive purposes or passed on to others.

Sales and distribution

SOMAS Instrument AB
P.O. Box 107
SE-661 23 SÄFFLE, Sweden
Visiting address: Norrlandsv. 26-28

Phone: +46 533 167 00
Mail to: sales@somas.se
Internet: www.somas.se



Product Information

SOMAS butterfly valves type MTV, MTVF and MTVL, are control, on/off and shut-off valves. These valves are designed to handle a wide range of liquids, gases and steam within a broad temperature range.

The MTV valve can be mounted between flanges and also supplied in lugged design.

The valve type MTVF is a full flanged butterfly valve.

The valves have an advanced triple eccentric design including a unique shape of the disc allows the use of a solid stainless steel seat.

The solid seat remains un-affected by high flow velocities and temperatures. A good valve function is achieved even on difficult applications.

SOMAS valves are delivered factory-tested and as complete units with actuators positioners and other accessories. The valves are ready for immediate installation/operation upon delivery.

Option

"Fire safe" (see datasheet Si-202 EN)



Tightness class

The tightness class is related to the chosen material in the seat ring.

Standard leakage class	Optional leakage class
EN 60534-4	EN 60534-4
PTFE - Class V	PTFE - Class VI
Metal - Class V	
	EN 12266-1
	PTFE - Rate B
	PTFE - Rate C
	Metal - Rate D

Pressure and temperature rating

Pressure, Bar, gauge

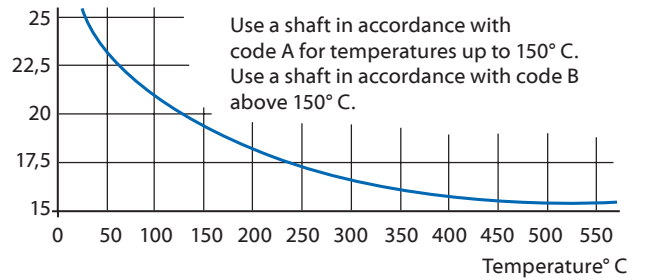

Minimum working temperature -60°. If lower temperatures are needed contact SOMAS.

Flow characteristics

Flow
100% Flow

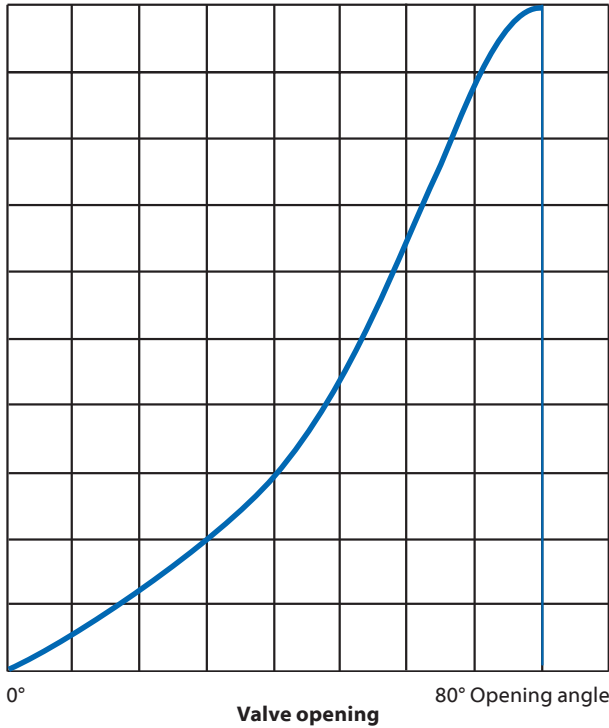

Pipe geometry factor Fp

Valve DN	Pipe DN	Opening angle								
		10°	20°	30°	40°	50°	60°	70°	80°	90°
80	100				0.99	0.99	0.96	0.93	0.91	0.93
	150	1.0	1.0	0.99	0.98	0.97	0.92	0.86	0.83	0.86
	200				0.97	0.94	0.88	0.81	0.77	0.81
100	150				0.98	0.97	0.93	0.88	0.84	0.88
	200	1.0	1.0	0.99	0.97	0.94	0.87	0.80	0.76	0.80
	250				0.96	0.93	0.85	0.77	0.72	0.77
125	150				0.98	0.95	0.91	0.91	0.88	0.91
	200	1.0	1.0	0.99	0.95	0.89	0.83	0.83	0.79	0.83
	250				0.93	0.86	0.78	0.78	0.74	0.78
150	200				0.98	0.95	0.91	0.91	0.88	0.91
	250	1.0	1.0	0.99	0.95	0.89	0.83	0.83	0.79	0.83
	300				0.93	0.86	0.78	0.78	0.74	0.78
200	250				0.99	0.98	0.96	0.93	0.91	0.93
	300	1.0	1.0	0.99	0.98	0.96	0.92	0.86	0.83	0.86
	350				0.97	0.94	0.88	0.81	0.77	0.81
250	300				0.99	0.99	0.97	0.95	0.93	0.95
	350	1.0	1.0	0.99	0.99	0.97	0.93	0.88	0.85	0.88
	400				0.98	0.95	0.90	0.83	0.80	0.83
300	350				0.99	0.99	0.98	0.96	0.95	0.96
	400	1.0	1.0	0.99	0.99	0.98	0.94	0.90	0.87	0.90
	500				0.98	0.96	0.91	0.85	0.82	0.85
350	400				0.99	0.99	0.97	0.95	0.93	0.95
	500	1.0	1.0	0.99	0.99	0.98	0.94	0.90	0.87	0.90
	600				0.98	0.96	0.91	0.85	0.82	0.85
400	500				0.99	0.99	0.99	0.97	0.97	0.97
	600	1.0	1.0	0.99	0.99	0.98	0.96	0.93	0.91	0.93
	700				0.98	0.96	0.91	0.85	0.82	0.85
500	600				0.99	0.99	0.99	0.98	0.98	0.98
	700	1.0	1.0	0.99	0.98	0.97	0.93	0.88	0.85	0.88
	800				0.98	0.95	0.89	0.83	0.79	0.83

Factor FLP

Factor	Opening angle								
	10°	20°	30°	40°	50°	60°	70°	80°	90°
FLP	0.88	0.86	0.82	0.80	0.74	0.68	0.61	0.60	0.59

Factor FLP is valid for all sizes

Liquid pressure recovery factor FL

Factor	Opening angle								
	10°	20°	30°	40°	50°	60°	70°	80°	90°
FL	0.88	0.86	0.82	0.80	0.74	0.68	0.61	0.60	0.59

Factor FL is valid for all sizes



Capacity factor K_v and Resistance factor ζ

DN	Opening angle									
	10°	20°	30°	40°	50°	60°	70°	80°	90°	ζ 90°
80	14	31	48	73	108	165	203	235	205	1,18
100	21	45	70	107	158	240	324	375	326	1,13
125	35	75	116	177	262	400	520	605	523	1,06
150	50	108	168	256	379	580	780	905	784	0,98
200	89	193	299	457	675	1030	1390	1610	1397	0,99
250	142	307	476	727	1076	1650	2211	2555	2222	0,95
300	207	446	692	1058	1566	2400	3219	3720	3235	0,93
350	279	602	934	1427	2111	3230	4341	5020	4362	0,95
400	371	800	1242	1898	2809	4300	5775	6675	5805	0,91
500	584	1258	1951	2981	4413	6760	9071	10485	9117	0,90

Relation between K_v and C_v : $C_v = 1.156 \times K_v$



Wafer design

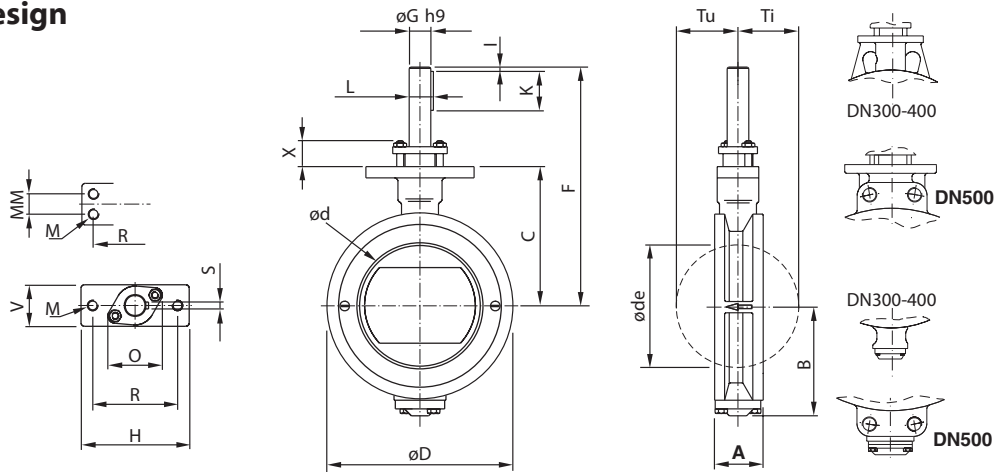

Butterfly valve type MTV																				Weight		
DN	A	B	C	ød	øde	øD	F	øG	H	I	K	L	M	MM	O	R	S	V	X	Tu	Ti	MTV
80	46	86	111	70	60	133	226	20	125	5	45	22.5	M12	-	61	98	6	40	30	41	38	5
100	52	99	128	90	86	160	243	20	125	5	45	22.5	M12	-	61	98	6	44	30	52	48	6
125	56	113	146	116	110	188	261	20	125	5	45	22.5	M12	-	61	98	6	48	30	64	60	9
150	56	127	161	140	138	215	276	25	125	5	45	28	M12	-	66	98	8	48	30	77	73	11
200	60	153	191	187	186	270	306	25	125	5	45	28	M12	-	66	98	8	48	30	100	96	17
250	68	188	225	236	235	324	360	30	150	5	60	33	M12	24	72	123	8	50	40	124	120	26
300	78	261	265	285	285	374	400	35	150	3	50	38	M12	24	75	123	10	60	40	149	145	39
350	78	287	294	331	330	432	449	40	150	3	50	43	M12	40	95	123	12	70	50	172	167	54
400	102	339	330	382	380	485	530	50	170	3	80	53.5	M16	55	105	136	14	87	50	199	194	82
500	127	339	395	479	475	590	605	60	210	3	90	64	M20	70	116	150	18	120	60	249	242	149

A = Face to face dimension according to EN 558 series 20
 øde = Necessary free diameter for the disc under movement

Lugged design

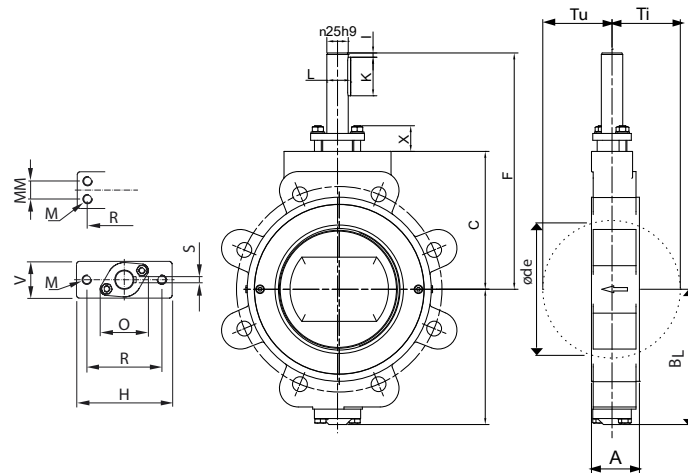

Drilled and threaded according to the ordered flange standard

Butterfly valve type MTVL																				Weight		
DN	A	BL	C	ød	øde	øD	F	øG	H	I	K	L	M	MM	O	R	S	V	X	Tu	Ti	MTVL
80	46	86	111	70	60	133	226	20	125	5	45	22.5	M12	-	61	98	6	40	30	41	38	10**/14
100	52	129	128	90	86	160	243	20	125	5	45	22.5	M12	-	61	98	6	44	30	52	48	11.5
125	56	137	146	116	110	188	261	20	125	5	45	22.5	M12	-	61	98	6	48	30	64	60	15.5
150	56	158	161	140	138	215	276	25	125	5	45	28	M12	-	66	98	8	48	30	77	73	18.5
200	60	191 ¹	191	187	186	270	306	25	125	5	45	28	M12	-	66	98	8	48	30	100	96	21* / 31
250	68	226	225	236	235	324	360	30	150	5	60	33	M12	24	72	123	8	50	40	124	120	45
300	78	261	265	285	285	374	400	35	150	3	50	38	M12	24	75	123	10	60	40	149	145	70
350	78	287	294	331	330	432	449	40	150	3	50	43	M12	40	95	123	12	70	50	172	167	100

*PN 10/Cl. 150 = 21 kg
 ** PN 10/16/25=14 kg, PN 20/Class 150=10 kg
 PN 16/25 = 31 kg

A = Face to face dimension according to EN 558 series 20
 øde = Necessary free diameter for the disc under movement



Wafer design

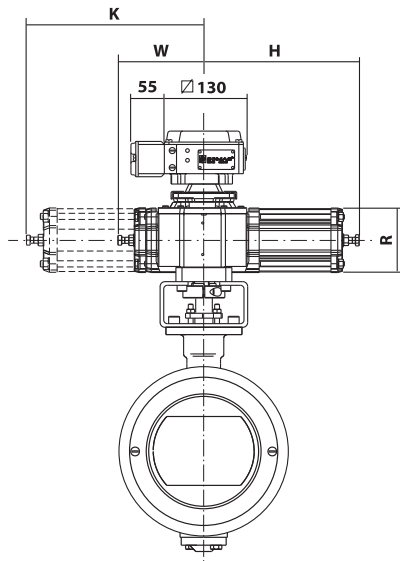

Lugged design

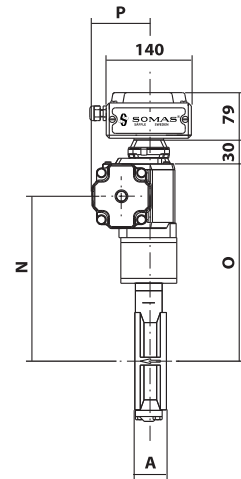
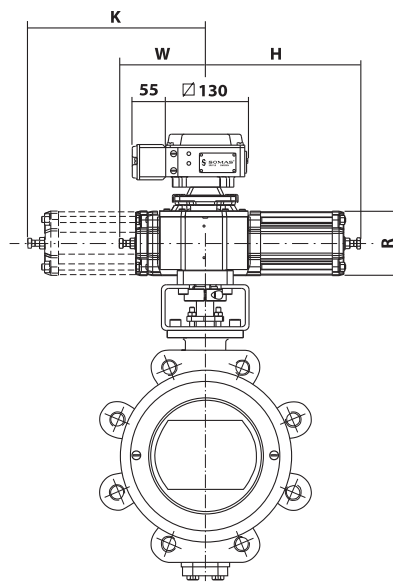

Butterfly valve type MTV/MTVL/MTVF with actuator type A-DA

DN	Type	H	K	N O		N O		P	R	W	Weight MTV	Weight MTVL	Weight MTVF
				MTV/MTVL	MTVF	MTV/MTVL	MTVF						
80	A13-DA	250	-	235	285	235	285	83	106	90	11	13	18
80	A21-DA	255	-	255	320	255	320	94	106	140	14	16	22
100	A21-DA	255	-	270	335	270	335	94	106	140	15	21	25
100	A22-DA	255	260	270	335	270	335	94	106	-	17	23	26
125	A21-DA	255	-	290	355	290	355	94	106	140	18	24	32
125	A22-DA	255	260	290	355	290	355	94	106	-	20	26	33
150	A21-DA	255	-	305	370	305	370	94	106	140	20	28	43
150	A22-DA	255	260	305	370	305	370	94	106	-	22	30	45
200	A22-DA	255	260	335	400	335	400	94	106	-	28	35	53
250	A22-DA	255	260	375	440	375	440	117	106	-	40	58	79
250	A23-DA	305	-	375	440	375	440	117	152	140	42	60	81
250	A24-DA	305	310	375	440	375	440	117	152	-	46	64	86
250	A31-DA	380	-	415	505	415	505	144	152	215	51	69	89
300	A31-DA	380	-	455	540	455	540	144	152	215	64	86	112
300	A32-DA	380	395	455	540	455	540	144	152	-	70	92	118
350	A31-DA	380	-	505	590	505	590	144	152	215	78	134	158
350	A32-DA	380	395	505	590	505	590	144	152	-	84	140	175
400	A32-DA	380	395	560	645	560	645	144	152	-	113	-	230
400	A33-DA	470	-	560	645	560	645	185	230	215	120	-	240
500	A41-DA	550	-	670	795	670	795	210	230	315	226	-	445
500	A42-DA	550	560	670	795	670	795	210	230	-	241	-	460

For units with the positioner type SP405, add 2 kg
For units with the positioner type SPE405, add 3 kg



Actuator type A-SC/SO

DN	Type	H	K	N	O	N	O	P	R	W	Weight MTV	Weight MTVL	Weight MTVF
				MTV/MTVL		MTVF							
80	A23-SO/SC	415	-	255	317	255	317	117	152	140	22	24	29
100	A23-SO/SC	415	-	270	335	270	335	117	152	140	24	30	33
100	A24-SO/SC	415	420	270	335	270	335	117	152	-	33	39	42
125	A23-SO/SC	415	-	290	355	290	355	117	152	140	30	32	37
150	A24-SO/SC	415	420	305	370	305	370	117	152	-	38	45	51
200	A24-SO/SC	415	420	335	400	335	400	117	152	-	44	51	69
250	A33-SO/SC	660	-	415	505	415	505	185	230	215	84	102	122
300	A33-SO/SC	660	-	455	540	455	540	185	230	215	97	119	145
350	A34-SO/SC	665	680	505	590	505	590	185	230	-	145	202	230
400	A34-SO/SC	665	680	560	645	560	645	185	230	-	174		345
400	A43-SO/SC	925	-	605	730	605	730	280	355	330	245	-	365
500	A43-SO/SC	925	-	670	795	670	795	280	355	330	311	-	477
500	A44-SO/SC	925	935	670	795	670	795	280	355	-	365	-	585

X = SC – Spring to close

X = SO – Spring to open

For units with the positioner type SP405, add 2 kg

For units with the positioner type SPE405, add 3 kg

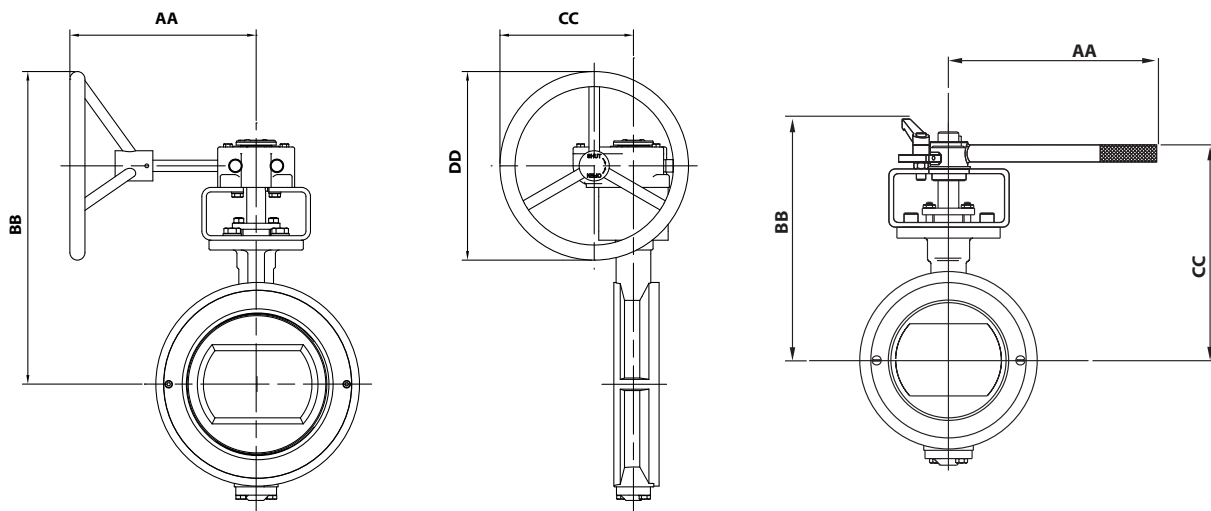

Butterfly valve type MTV with gear unit

DN	Type	AA	BB	CC	øDD	Weight
80	AB215N	247	342	177	200	13
100	AB215N	247	357	177	200	14
125	AB215N	247	372	177	200	17
150	AB215N	247	386	177	200	19
200	AB215N	247	414	177	200	25
250	AB550N	284	487	221	300	39
300	AB550N	284	526	221	300	52
350	AB550N	284	589	221	300	65
400	AB880N	277	667	261	350	102
500	AB2000N	320	866	320	500	184

Butterfly valve type MTV with hand lever

DN	Type	AA	BB	CC	Weight
80	HSR20	355	236	206	8
100	HSR20	355	251	223	9
125	HSR20	355	271	241	12



Flanged design

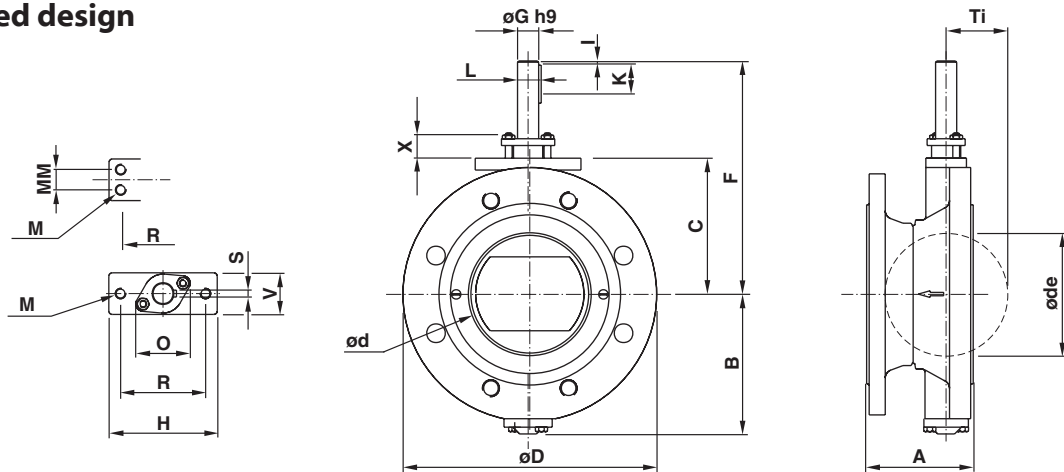

Butterfly valve type MTVF

DN	A	B	C	ød	øde	øD	F	øG	øH	I	K	L	M	MM	O	R	S	V	X	Ti	Weight ¹
80	114	113	111	70	60	According to the flange standard	226	20	125	5	45	22.5	M12	-	61	98	6	40	30	38	14
100	127	130	128	90	86		243	20	125	5	45	22.5	M12	-	61	98	6	44	30	48	17.5
125	140	150	146	116	110		261	20	125	5	45	22.5	M12	-	61	98	6	48	30	60	24
150	140	165	161	140	138		276	25	125	5	45	28	M12	-	66	98	8	48	30	73	34
200	152	195	191	187	186		306	25	125	5	45	28	M12	-	66	98	8	48	30	96	42
250	165	224	225	236	235		360	30	150	5	60	33	M12	24	72	123	8	50	40	120	64
300	178	261	265	285	285		400	35	150	3	50	38	M12	24	75	123	10	60	40	145	100
350	190	297	294	331	330		449	40	150	3	50	43	M12	40	95	123	12	70	50	167	157
400	216	320	330	382	380		530	50	170	3	80	53.5	M16	55	105	136	14	87	50	194	254
500	229	375	395	479	475		605	60	210	3	90	64	M20	70	116	150	18	120	60	242	315

A = Face to face dimension according to EN 558 series 13

øde = Necessary free diameter for the disc under movement

¹ Approximate value dependent on PN-class

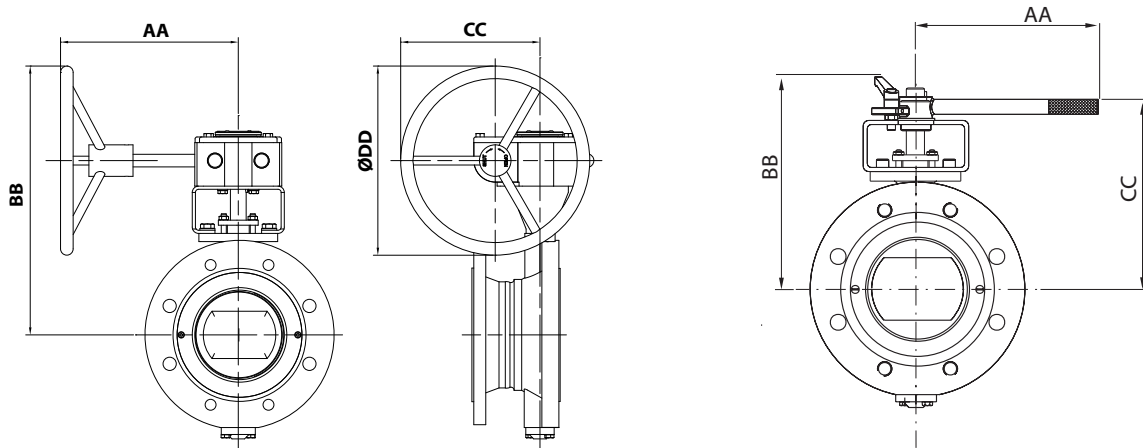

Butterfly valve type MTVF with gear unit

DN	Type	AA	BB	CC	øDD	Weight ¹
80	AB215N	247	342	177	200	22
100	AB215N	247	357	177	200	25.5
125	AB215N	247	372	177	200	32
150	AB215N	247	386	177	200	42
200	AB215N	247	414	177	200	50
250	AB550N	284	487	221	300	77
300	AB550N	284	526	221	300	112
350	AB550N	284	589	221	300	170
400	AB880N	277	667	261	350	274
500	AB2000N	320	866	320	500	450

Butterfly valve type MTVF with hand lever

DN	Type	AA	BB	CC	Weight ¹
80	HSR20	355	236	206	15
100	HSR20	355	251	223	18
125	HSR20	355	271	241	25

¹ Approximate value dependent on PN-class

¹ Approximate value dependent on PN-class



Flanged design

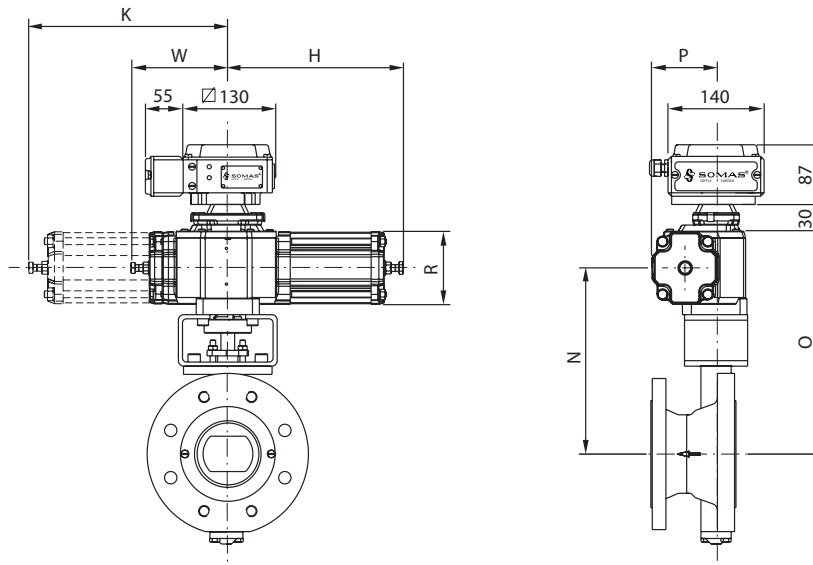

Butterfly valve type MTFV with actuator type A-DA

DN	Type	H	K	N	O	P	R	W	Weight ¹
80	A13	250	-	235	285	83	106	90	18
80	A21	255	-	255	320	94	106	140	22
100	A21	255	-	270	335	94	106	140	25
100	A22	255	260	270	335	94	106	-	26
125	A22	255	260	290	355	94	106	-	33
150	A22	255	260	305	370	94	106	-	38
200	A22	155	260	335	400	94	106	-	53
250	A23	305	-	380	445	117	152	140	81
250	A31	380	-	420	510	144	152	215	89
300	A31	380	-	460	550	144	152	215	112
300	A32	380	395	460	550	144	152	-	118
350	A32	380	395	505	590	144	152	-	175
400	A32	380	395	560	645	144	152	-	230
400	A33	470	-	560	645	185	230	215	240
500	A41	550	-	670	795	210	230	315	445
500	A42	545	560	670	795	210	230	-	460

For units with the positioner type SP405, add 2 kg
 For units with the positioner type SPE405, add 3 kg

Actuator type A-SC/SO

DN	Type	H	K	N	O	P	R	W	Weight ¹
80	A23-X	415	-	255	320	117	152	140	29
100	A24-X	415	420	270	335	117	152	-	42
125	A24-X	415	420	290	355	117	152	-	49
150	A24-X	415	420	305	370	117	152	-	54
200	A24-X	415	420	335	400	117	152	-	69
250	A33-X	660	-	420	510	185	230	215	122
300	A33-X	660	-	460	550	185	230	215	145
350	A34-X	665	680	505	590	185	230	-	230
400	A43-X	920	-	605	730	280	355	315	365
500	A44-X	925	935	670	795	280	355	-	585

X = SC – Spring to close

X = SO – Spring to open

For units with the positioner type SP405, add 2 kg

For units with the positioner type SPE405, add 3 kg

¹ Approximate value dependent on PN-class



Actuator selection table for Butterfly Valves

Air supply 5.5 bar

Valve DN	Shaft (mm) dia.	Closing torque (Nm)			Double acting 5,5 (bar) supply air		Single acting 5,5(bar) supply air	
		$\Delta p > 10(\text{bar})$	$\Delta p \leq 10(\text{bar})$	Max allowable	$\Delta p > 10(\text{bar})$	$\Delta p \leq 10(\text{bar})$	$\Delta p > 10(\text{bar})$	$\Delta p \leq 10(\text{bar})$
80	20	120	100	150	A21-DA	A21-DA	A23-SC/SO	A23-SC/SO
100	20	165	120	220	A21-DA	A21-DA	A24-SC/SO	A23-SC/SO
125	20	180	165	220	A22-DA	A21-DA	A24-SC/SO	–
150	25	250	200	300	A22-DA	A21-DA	A24-SC/SO	A24-SC/SO
200	25	290	250	350	A22-DA	A22-DA	A24-SC/SO	A24-SC/SO
250	30	500	400	600	A23-DA	A22-DA	A33-SC/SO	A33-SC/SO
300	35	620	500	750	A31-DA	A31-DA	A33-SC/SO	A33-SC/SO
350	40	1000	800	1200	A32-DA	A31-DA	A34-SC/SO	A34-SC/SO
400	50	1350	1000	1600	A32-DA	A32-DA	A43-SC/SO	A34-SC/SO
500	60	2700	1900	3250	A41-DA	A41-DA	A44-SC/SO	A43-SC/SO

Actuator selection table for Butterfly Valves

Air supply 4 bar

Valve DN	Shaft (mm) dia.	Closing torque (Nm)			Double acting 4,0(bar) supply air		Single acting 4,0(bar) supply air	
		$\Delta p > 10(\text{bar})$	$\Delta p \leq 10(\text{bar})$	Max allowable	$\Delta p > 10(\text{bar})$	$\Delta p \leq 10(\text{bar})$	$\Delta p > 10(\text{bar})$	$\Delta p \leq 10(\text{bar})$
80	20	120	100	150	A21-DA	A21-DA	A23-SCL/SOL	A23-SCL/SOL
100	20	165	120	220	A22-DA	A21-DA	A24-SCL/SOL	A23-SCL/SOL
125	20	180	165	220	A22-DA	A22-DA	A24-SCL/SOL	A24-SCL/SOL
150	25	250	200	300	A22-DA	A22-DA	A24-SCL/SOL	A24-SCL/SOL
200	25	290	250	350	A22-DA	A22-DA	A24-SCL/SOL	A24-SCL/SOL
250	30	500	400	600	A31-DA	A24-DA	A33-SCL/SOL	A33-SCL/SOL
300	35	620	500	750	A32-DA	A31-DA	A33-SCL/SOL	A33-SCL/SOL
350	40	1000	800	1200	A32-DA	A32-DA	A34-SCL/SOL	A34-SCL/SOL
400	50	1350	1000	1600	A33-DA	A32-DA	A43-SCL/SOL	A34-SCL/SOL
500	60	2700	1900	3250	A42-DA	A41-DA	A44-SOL	A43-SCL/SOL

SC = Spring to close at air failure

SO/SOL = Spring to open at air failure

Manual override

Valve DN	Shaft dia. (mm)	Hand lever	Gear unit
80	20	HSR020	AB215N
100	20	HSR020	AB215N
125	20	HSR020	AB215N
150	25	–	AB215N
200	25	–	AB215N
250	30	–	AB550N
300	35	–	AB550N
350	40	–	AB550N
400	50	–	AB880N
500	60	–	AB2000N



Flange standard

SOMAS butterfly valve type MTV in this data sheet is of wafer type for mounting between flanges PN10 - 25.

The valve can also be delivered in lugged design, MTVL.

The butterfly valve type MTVF is equipped with flanges which can be drilled for PN10 - 25.

Both types of valve can also be drilled for mounting between flanges according to ASME.

When ordering, please always state the pressure rating of the counter flanges. See the valve specification system on page 15, code 13.

Seat design

The valves have a metal seat (type Y) according to code D.

PTFE and nickel alloy seat for firesafe design is available as an option.

Further technical information

Technical data for the materials used in the SOMAS valves, flange standard, steam data, etc. can be found in documents library on www.somas.se.

Data sheet Si-203 shows butterfly valve type VSS for nominal sizes above DN500.

Actuators and accessories

The valves can be fitted with SOMAS manual, on/off or control actuators in accordance with the selection table. The valves will then be delivered as tested units ready for installation.

In the documents library on www.somas.se there is also information about positioners, limit switches and solenoid valves.

We can also fit other types of actuators and accessories in accordance with your specification.



Max. allowable pressure drops/torque figures

Maximum allowable pressure drops are valid at 20° C (see below).

Valve DN	PN	Max. pressure drop. bar at opening angle			Torque min. at ΔP		Torque min. at ΔP		Torque max. shaft
		0°	60°	80°	bar	Nm	bar	Nm	Nm
80	25	25	13	4.4	≤ 10	100	> 10	120	150
100	25	25	13	4.4	≤ 10	120	> 10	165	220
125	25	25	15	5.8	≤ 10	165	> 10	180	220
150	25	25	9	2.7	≤ 10	200	> 10	250	300
200	25	25	4.3	1.1	≤ 10	250	> 10	290	350
250	25	25	3.6	1.05	≤ 10	400	> 10	500	600
300	25	20	3.6	1.05	≤ 10	500	> 10	620	750
350	25	20	3.6	1.09	≤ 8	800	> 8	1000	1200
400	25	20	4.7	1.43	≤ 8	1000	> 8	1350	1600
500	25	15	4.4	1.19	≤ 6	1900	> 6	2700	3250

Supplemental information

Note: Use flat gaskets with the correct inside diameter to ensure that pressure is applied on the cover plate. Spiral-wound gaskets shall not be used.

For mounting between flanges according to PN10-25, the inside gasket diameter should not exceed the dimensions specified in the standard EN 1514-1.

For mounting between flanges according to Class 150 dimensions according to the standard ASME B 16.21 RF are valid where the following dimensions refer to the gasket.

Valve DN	Gaskets according to EN 1514-1			
	Max. Inside dia. di (mm)	Outside dia. (dy) (mm)		
		PN 10	PN 16	PN 25
80	89	142	142	142
100	115	162	162	168
125	141	192	192	194
150	169	218	218	224
200	220	273	273	284
250	273	328	329	340
300	324	378	384	400
350	356	438	444	457
400	407	489	495	514
500	508	594	617	624

Valve DN	Gaskets according to ASME B 16.21 RF	
	Max. Inside dia. di (mm)	Outside dia. (dy) (mm) Class 150
80	89	136
100	114	174
125	141	196
150	168	222
200	219	279
250	273	340
300	324	410
350	356	451
400	406	515
500	508	606



Variants

The standard MTV valve is designed to be mounted between flanges (wafer), but is also available in lugged and flanged design.

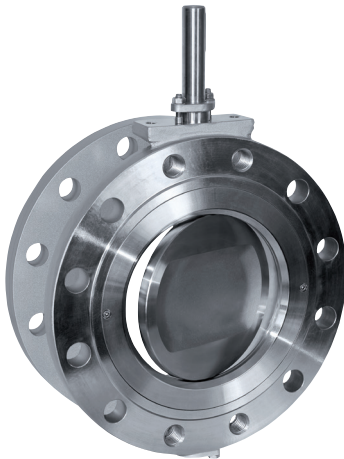

MTVF
Flanged design

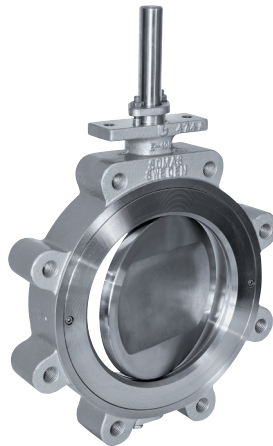

MTVL
Lugged design

Ordering

State desired valve according to the valve specification system below as well as type of actuator, positioner and accessories.

Temperature range

Seat	Max. temp.
A = PTFE (10 % carbon)	170° C
D = 1.4462 alt. 1.4470 (metal seat, type Y)	350° C ¹ 550° C ²
E = 1.4547	500° C
P = PTFE (fibreglass 15%)	170° C
N = 1.4835, seat type Y	550° C

Shaft	Max. temp.
A = 1.4460 alt. SS 2324-12	150° C
B = 1.4460 alt. SS 2324-12, hard chromed	350° C ¹ 550° C ²
C = 1.4460 alt. SS 2324-12, HiCo Gr 6 coated	350° C ¹ 550° C ²
G = 1.4404, hard chromed	
J = CK3MCuN / 1.4547	500° C
S = 1.4469 alt. 1.4410	150° C
T = Titan gr.2	200° C ³
Y = 1.4462 alt. 1.4470, hard chromed	150° C
Z = 1.4462 alt. 1.4470	350° C ¹ 550° C ²

Valve body	Max. temp.
A = CF8M/1.4408	550° C
E = CK3MCuN	500° C
H = 1.4470	250° C
S = Titan Gr C-2 / Gr 2	200° C
Z = 1.4469	250° C

¹ Check with SOMAS for temperatures between 350 and 550° C. At higher pressures for example steam turbine applications.

² At lower pressures for example exhaust applications.

³ seat, sealings and bearings may limit the temperature below 200° C.



Valve specification system

MTV - A 5 - A A D - A 1 1 - DN... - D... - B... - PN...

1
2
3
4
5
6
7
8
9
10
11
12
13

1 Type of valve

Wafer design
 MTV
 Flanged design
 MTVF
 Lugged design
 MTVL

2 Valve body design

A = Wafer design
 F = Lugged design
 L = Flanged design

3 Nominal pressure

4 = Class150
 5 = PN25

4 Material - valve body

A = CF8M / 1.4408
 E = CK-3MCuN
 H = 1.4470
 S = Titan Gr C-2 / Gr 2
 Z = 1.4469

5 Material – disc

A = CF8M/1.4408 alt. 1.4401
 B = CF8M/1.4408 alt. 1.4401,
 hard chromed
 C = CF8M/1.4408 alt. 1.4401,
 HiCo Gr 21 coated
 H = 1.4462 alt. 1.4470
 N = 1.4469 alt. 1.4410
 S = CK-3MCuN alt. 1.4547
 U = Titan Gr C-2 / Gr 2

6 Material – seat

A = PTFE (10 % carbon,
 percentage by weight)
 D = 1.4462 alt. 1.4470, (metal seat,
 type Y)
 E = 1.4547
 N = 1.4835, seat type Y
 P = PTFE, glass fiber filled 15 %

7 Material – shaft

A = 1.4460 alt. SS 2324-12
 B = 1.4460 alt. SS 2324-12,
 hard chromed
 C = 1.4460 alt. SS 2324-12,
 HiCo Gr 6 coated
 F = 1.4404
 G = 1.4404 hard chromed
 J = CK3MCuN / 1.4547
 S = 1.4469 alt. 1.4410
 T = Titan gr.2
 N = 1.4835
 Y = 1.4462 alt. 1.4470,
 hard chromed
 Z = 1.4462 alt. 1.4470

8 Bearing – valve body/shaft

1 = Without bearing
 4 = PTFE (Rulon)
 6 = N06625 (High Nickel Alloy)
 7 = 1.4462

9 Stuffing box

1 = Graphite
 2 = PTFE

10 Valve size, DN

11 Shaft diameter

12 Actuator mounting flange drilling

13 Drilling, counter flanges PN/ Class

*Other materials are available on request.
 Contact Somas for further information.*

SOMAS reserves the right to make improvements without prior notice.



Concern and head office:
SOMAS Instrument AB
Norrlandsvägen 26
SE-661 40 SÄFFLE
Sweden

Phone: +46 (0)533 167 00
E-mail: sales@somas.se
www.somas.se

