



# HART® to Modbus® Adaptor

## Operating Manual



Eclipse® Model 706  
Guided Wave Radar Level Transmitter





# TABLE OF CONTENTS

SETUP PROCEDURES .....	6
1. CONFIGURING COMMUNICATIONS SETTINGS IN THE HMA.....	6
2. READING AND WRITING REGISTERS IN THE HMA.....	9
3. BASIC MODBUS RTU COMMUNICATION OVER RS-485.....	13
4. BASIC MODBUS RTU COMMUNICATION OVER RS-232.....	14
5. BASIC MODBUS ASCII COMMUNICATION OVER RS-485 .....	15
6. MODBUS RTU COMMUNICATION IN SINGLE DEVICE MODE.....	17
7. MODBUS RTU COMMUNICATION IN DEVICE MODE.....	18
8. MODBUS RTU COMMUNICATION IN HMA MODE .....	21
9. BASIC LEVELMASTER COMMUNICATION.....	25
10. ADDITIONAL LEVELMASTER COMMANDS .....	29
11. AUTO SWITCHING BETWEEN MODBUS RTU/ASCII AND HART OVER RS-485 COMMUNICATION .....	34
12. AUTO SWITCHING BETWEEN LEVELMASTER AND HART OVER RS-485 COMMUNICATION .....	38
13. HMA DIAGNOSTICS .....	43
14. ROCLINK 800 .....	47
15. ABB TOTALFLOW XRC – MODBUS RTU / ASCII .....	56
16. ABB TOTALFLOW XRC – LEVELMASTER .....	73
17. THERMOSCIENTIFIC AUTOPILOT PRO – MODBUS RTU / ASCII.....	85
APPENDICES .....	95
A. HMA TERMINAL BLOCK LAYOUT .....	95
B. HMA DIP SWITCH SETTINGS.....	96
C. HMA LED INDICATORS .....	96
D. HMA SYSTEM CONNECTION DIAGRAM .....	97
E. NOMENCLATURE TABLE .....	97
F. HMA COMMUNICATION MODBUS REGISTERS .....	98
G. HMA DIAGNOSTICS MODBUS REGISTERS.....	99
H. HMA DEVICE INFORMATION MODBUS REGISTERS.....	100
I. MODEL 706, MODEL JM4 MODBUS REGISTERS .....	101
J. MODEL 705 3X MODBUS REGISTERS .....	102
K. MODEL R82 R2 MODBUS REGISTERS .....	103
L. MODEL RX5 MODBUS REGISTERS.....	104
M. MODEL 355 MODBUS REGISTERS .....	105
N. ENHANCED JUPITER MODBUS REGISTERS .....	106
O. E3 MODULELEVEL MODBUS REGISTERS.....	107
P. LEVELMASTER ERROR AND WARNING CODES.....	108
Q. LEVEL UNIT CODES .....	110
R. PARAMETER CODES .....	110

## INTRODUCTION

The HART to Modbus Adaptor (HMA) is designed to allow Magnetrol HART transmitters to be utilized in a Modbus<sup>®1</sup> system. The following Modbus protocols are supported:

- Modbus RTU – Function codes 3, 4, 6, and 16
- Modbus ASCII – Function codes 3, 4, 6, and 16
- Levelmaster – Commands [Uxx?](#), [UxxF?](#), [UxxOL?](#), and [UxxOLxxx?](#)

The HMA will support up to five attached HART devices; one in the same housing as the HMA, and up to four external devices attached through a 4-20 mA loop. The HMA provides power for all attached HART units. Note that the unit should be set to a fixed 4 mA loop current.

### **Communication**

Within the above protocols, it is possible to [change communications parameters](#) such as baud rate, parity, stop bits, etc. to match the settings for a particular Modbus RTU or host.

To ensure a standard way to communicate with the HMA, setting DIP switch position 1 to OFF (see Appendix A) will configure the HMA to communicate via Modbus RTU with the default communications settings shown in Appendix F.

### **Operating Modes**

When using the Modbus RTU and ASCII protocols, the HMA can be used in two basic ways:

1. [Single Device](#) – The HMA is connected to only the HART device present in the same transmitter housing. The HART poll address of the HART device and the Modbus poll address of the HMA are the same. Essentially, they appear to a Modbus master as a single native Modbus device.
2. Multiple Devices – Up to five HART devices can be connected to an HMA. The devices can be accessed via two modes:
  - [Device](#) – The Modbus host addresses the HART devices directly, using the HART Poll Address of each device as the Modbus address. (The HMA is essentially transparent.) The registers for each attached device type are the same regardless of the poll address. The HART devices will appear to be native Modbus devices to the Modbus host.
  - [HMA](#) – The Modbus host addresses the HMA directly, using only the address of the HMA. The registers in the HMA for each attached device depend on the slave number of the attached devices. The HMA will appear to be a Modbus device capable of providing multiple level measurements.

### **Supported Device Parameters**

Not all of the parameters for a particular HART device are supported by the HMA using Modbus communication. The parameters that are available have been chosen to represent the most commonly used or adjusted parameters for the device. The available parameters are listed in Appendices I through O.

### **Full Device Configuration**

---

<sup>1</sup> Modbus<sup>®</sup> is a registered trademark of Schneider Electric, licensed to the Modbus Organization, Inc.

The HMA is also capable of passing [HART commands using the RS-485 connection](#) to the attached devices. Alternatively, a HART modem can be connected directly to the HART terminal block on the HMA<sup>2</sup>. These modes can be used to utilize a hand-held communicator or PACTware with a DTM to set up or troubleshoot an attached HART device. Using a DD or DTM, the full range of the HART device's parameters can be accessed.

This document is intended to provide a guide for utilizing the various features of the Magnetrol HART to Modbus Adaptor. For each feature, a step-by-step procedure is provided to demonstrate how to set up the HMA and attached HART devices for a particular configuration. Other configurations are possible with various combinations of the number of HART to Modbus Adapters on a single RS-485 line and the number and type of Magnetrol HART devices attached to those HART to Modbus Adapters. The operations in those configurations can be accomplished by extending the procedures provided in this document. Additionally, it is not required to use the Modbus RTUs or host applications shown in this document. Any RTU or host application can be used that allows for reading and writing Modbus registers in a slave device.

---

<sup>2</sup> The HMA will always act as a primary master on the HART loop. Therefore, if connecting another HART host to the loop, it must either be capable of automatically setting itself to be a secondary master, or be manually configured as a secondary master.

## SETUP PROCEDURES

### 1. Configuring communications settings in the HMA

#### 1.1. Purpose

This setup procedure instructs how to configure HART to Modbus Adaptor (HMA) communications using a basic Modbus master simulator application. The procedure can also be performed using any Modbus master that permits reading and writing of the appropriate registers in the HMA.

To ensure that there is a known communication configuration for the HMA, position 1 of the DIP switch is used to select between a fixed communication setting and a user-configurable setting. When the switch is set to OFF, the HMA communicates using Modbus RTU with a poll address of 247 at 9600 baud, 8 data bits, even parity, and 1 stop bit. When in the default configuration, the user-selectable communication settings can be adjusted. When the user settings are desired to be used, position 1 of the DIP switch should be set to ON, and then input power cycled. Changing back to the fixed default settings also requires a power cycle.

#### 1.2. Equipment

Item	Manufacturer	Model
HART to Modbus Adaptor	MII	031-2859-001
USB Communications cable	FDTIchip	USB-RS485-WE
Termination resistor	-	120Ω
Modbus host application	<a href="http://www.modbustools.com">www.modbustools.com</a>	Modbus Poll
Power Supply	-	20-24V, 0.5A

#### 1.3. Setup

Connect the HMA to a power supply via the power terminal block. Connect an RS-485 communications cable to the RS-485 terminal block of the HMA, with the Receive/Transmit Data+ A lead (orange) on the positive terminal and the Receive/Transmit Data- B lead (yellow) on the negative terminal. Connect a 120Ω resistor between the two RS-485 terminal block positions. Connect the other end of the cable to a PC which has a Modbus host application.

#### 1.4. Procedure

- 1.4.1 Connect the HMA to a power supply and Modbus host as specified in section 1.3.
- 1.4.2 Ensure that the DIP switches on the HMA are set to 1 == OFF (Default Config Mode), 2 == OFF, 3 == OFF, 4 == ON. See Appendix A for the location of the DIP switch, and Appendix B for a legend of the four switch positions.
- 1.4.3 Open the Modbus Poll application.

- 1.4.4 Select Connection\Connect from the menu bar, ensure that the connection settings are as follows, and then click OK. Note that the USB Serial Port setting needs to match the port number for the communication cable that is being used.

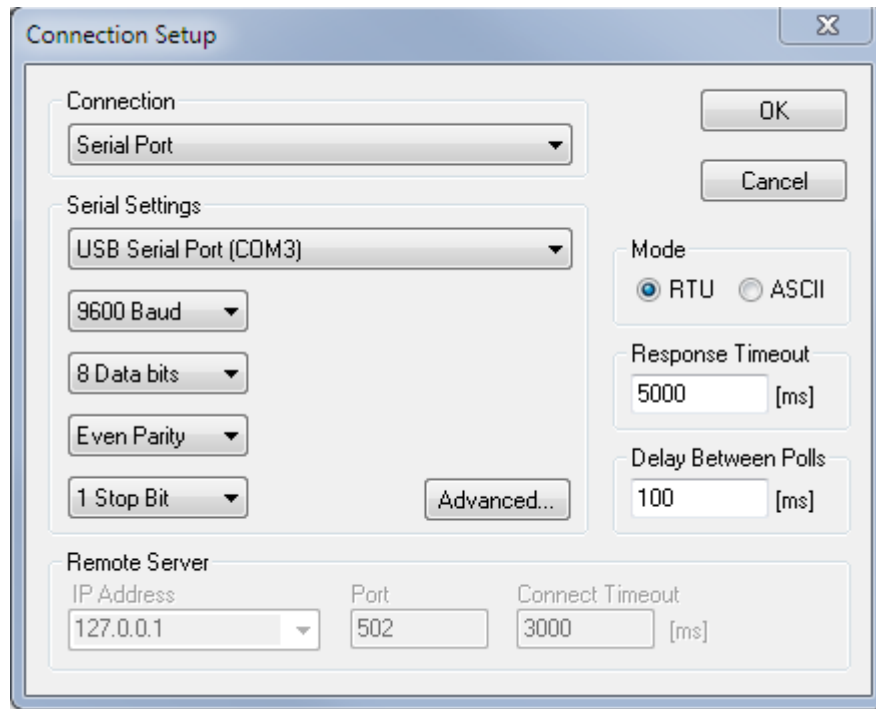

- 1.4.5 Open or click on an Mbpoll window, select Setup\Read\Write Definition from the menu bar, ensure that the settings are as follows, and then click OK:

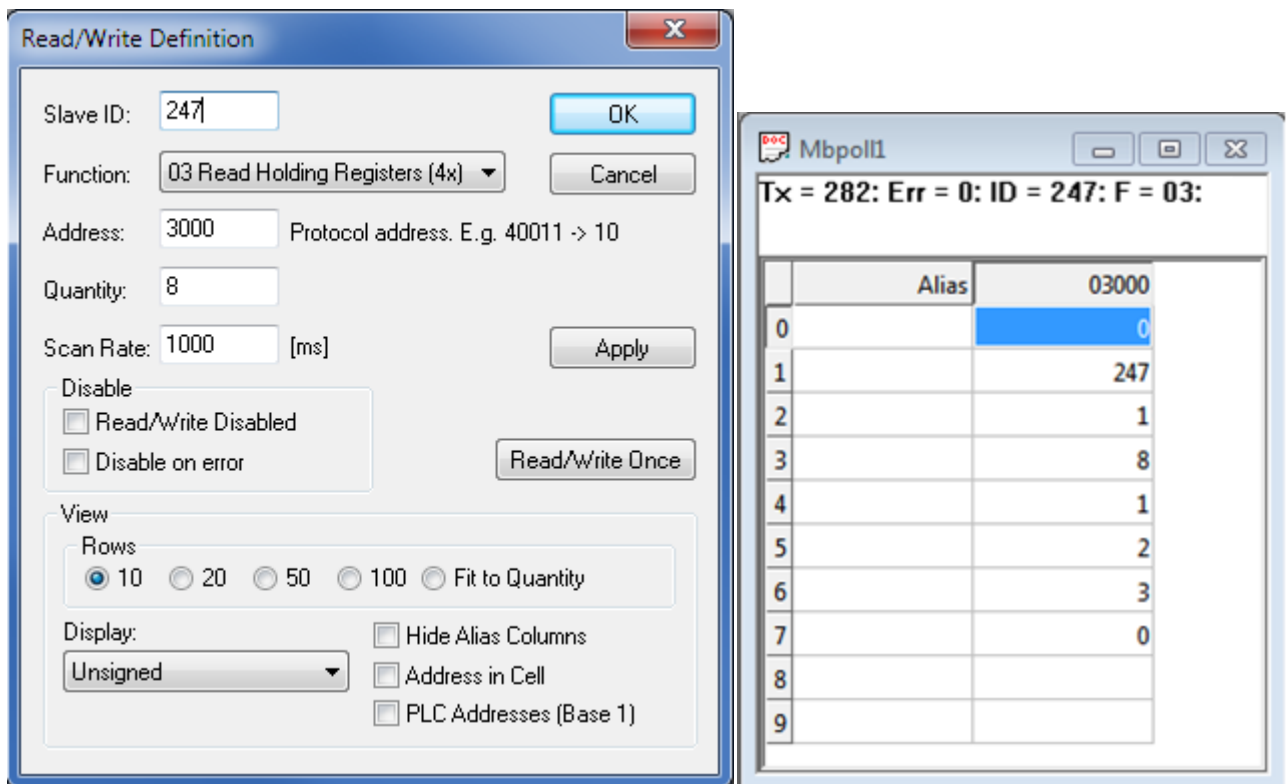

- 1.4.6 Verify that the values in the registers listed in the Mbpoll window match the values for the desired Modbus protocol settings. Refer to Appendix F for the HMA Communication settings. If the settings do not match, double-click on a value that needs to be changed in order to open the Write Single Register dialog, enter the new value, and then click on Send.
- 1.4.7 Power down the HMA, change DIP switch 1 to ON, and then reapply power to the HMA. This sets the device to run in the selected communications mode.
- 1.4.8 If communication at the new settings is not achieved, power down the HMA, change DIP switch 1 to OFF, and then reapply power to the HMA. This sets the device to run in the default Modbus RTU communications mode. Check the communication setting registers to ensure that the desired values are present.



## 2. Reading and writing registers in the HMA

### 2.1. Purpose

This setup procedure instructs how to read and write HART to Modbus Adaptor (HMA) registers using a basic Modbus master simulator application. The procedure can also be performed using any Modbus master that permits reading and writing of the appropriate registers in the HMA.

### 2.2. Equipment

Item	Manufacturer	Model
HART to Modbus Adaptor	MII	031-2859-001
USB Communications cable	FDTIchip	USB-RS485-WE
Termination resistor	-	120Ω
Modbus host application	<a href="http://www.modbustools.com">www.modbustools.com</a>	Modbus Poll
Power Supply	-	20-24V, 0.5A

### 2.3. Setup

Connect the HMA to a power supply via the power terminal block. Connect an RS-485 communications cable to the RS-485 terminal block of the HMA, with the Receive/Transmit Data+ A lead (orange) on the positive terminal and the Receive/Transmit Data- B lead (yellow) on the negative terminal. Connect a 120Ω resistor between the two RS-485 terminal block positions. Connect the other end of the cable to a PC which has a Modbus host application.

### 2.4. Procedure

- 2.4.1 Connect the HMA to a power supply and Modbus host as specified in section 2.3.
- 2.4.2 Ensure that the DIP switches on the HMA are set to 1 == OFF (Default Config Mode), 2 == OFF, 3 == OFF, 4 == ON. See Appendix A for the location of the DIP switch, and Appendix B for a legend of the four switch positions.
- 2.4.3 Open the Modbus Poll application.

- 2.4.4 Select Connection\Connect from the menu bar, ensure that the connection settings are as follows, and then click OK. Note that the USB Serial Port setting needs to match the port number for the communication cable that is being used.

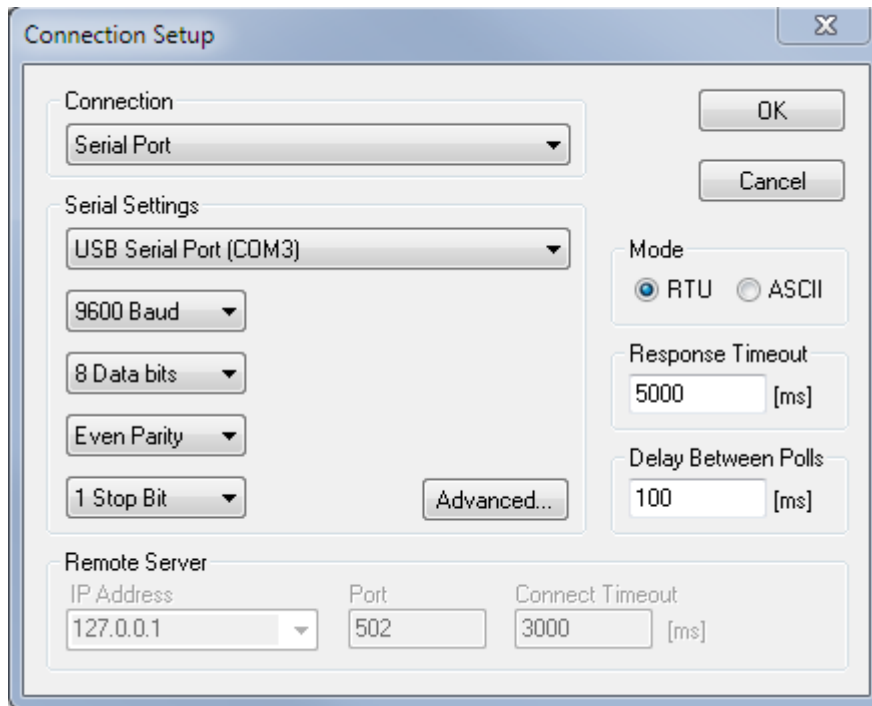

2.4.5 To read an input register, open or click on an Mbpoll window, and select Setup\Read\Write Definition from the menu bar. Set the Slave ID to match the Modbus Poll Address of the HMA. Set the Function to '04 Read Input Registers (3x)'. Using Appendices I through O, set the Address, Quantity and Display type in the pop-up dialog as required. Then click OK. The register value should appear in the Mbpoll window.

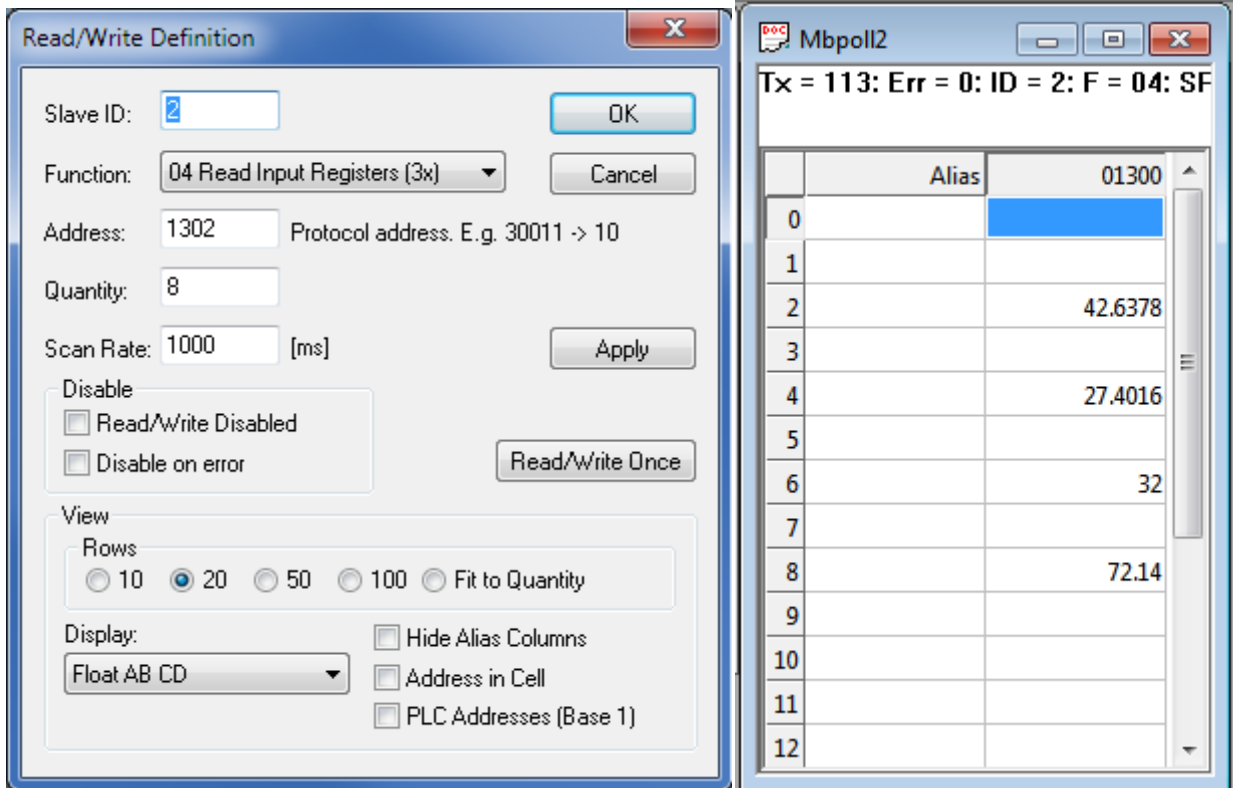

2.4.6 To read a holding register, open or click on an Mbpoll window, and select Setup\Read\Write Definition from the menu bar. Set the Slave ID to match the Modbus Poll Address of the HMA. Set the Function to '03 Read Holding Registers (4x)'. Using Appendices I through O, set the Address, Quantity and Display type in the pop-up dialog as required. Then click OK. The register value should appear in the Mbpoll window.

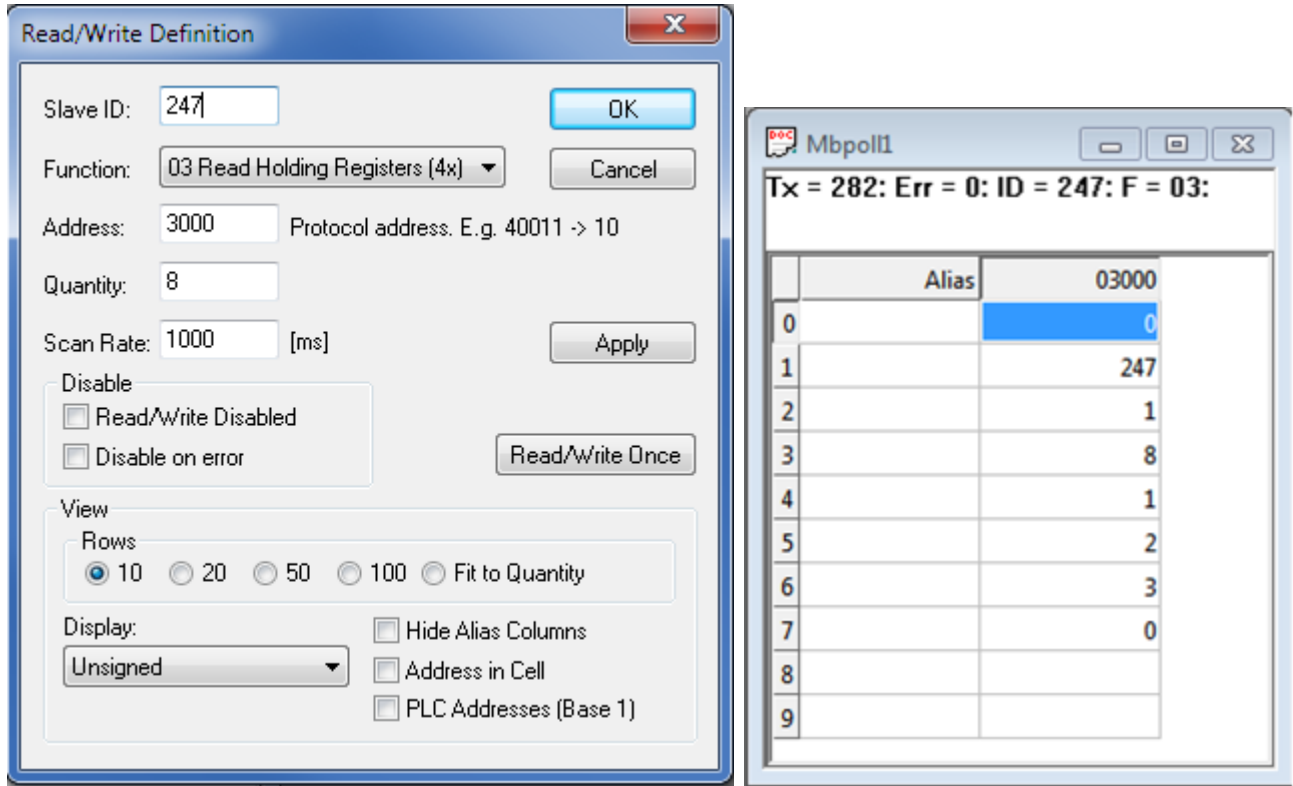

2.4.7 To write a holding register, double-click on the register value displayed in step 2.4.6. Enter the new value and click on 'Send'. Confirm that the new value appears in the Mbpoll window.

### 3. Basic Modbus RTU Communication over RS-485

#### 3.1. Purpose

This setup procedure instructs how to configure the HART to Modbus Adaptor (HMA) to support the Modbus RTU protocol over RS-485.

#### 3.2. Equipment

Item	Manufacturer	Model
HART to Modbus Adaptor	MII	031-2859-001
USB Communications cable	FDTIchip	USB-RS485-WE
Termination resistor	-	120Ω
Modbus host application	<a href="http://www.modbustools.com">www.modbustools.com</a>	Modbus Poll
Power Supply	-	20-24V, 0.5A
Level transmitter	MII	Model 706
Probe	MII	Model 706 compatible

#### 3.3. Setup

Connect the HMA to a power supply via the power terminal block. Connect an RS-485 communications cable to the RS-485 terminal block of the HMA, with the Receive/Transmit Data+ A lead (orange) on the positive terminal and the Receive/Transmit Data- B lead (yellow) on the negative terminal. Connect a 120Ω resistor between the two RS-485 terminal block positions. Connect the other end of the cable to a PC which has a Modbus host application.

#### 3.4. Procedure

- 3.4.1 Using Procedure 1, ensure that registers 3000 through 3007 of the HMA match the values shown for the Modbus RTU protocol default settings. Refer to Appendix F for the HMA Communication settings. If the settings do not match, double-click on a value that needs to be changed in order to open the Write Single Register dialog, enter the new value, and then click on Send.
- 3.4.2 Change DIP switch 1 to ON. This sets the device to run in the selected communications mode.
- 3.4.3 Remove power from the HMA.
- 3.4.4 Connect the HMA to a Modbus master.
- 3.4.5 Apply power to the HMA.
- 3.4.6 Verify that the Modbus master is receiving responses from the HMA (Tx is increasing) and that there are no communication errors being reported.

## 4. Basic Modbus RTU Communication over RS-232

### 4.1. Purpose

This setup procedure instructs how to configure the HART to Modbus Adaptor (HMA) to support the Modbus protocol over RS-232.

### 4.2. Equipment

Item	Manufacturer	Model
HART to Modbus Adaptor	MII	031-2859-001
Serial Communications cable	-	-
Termination resistor	-	120Ω
Modbus host application	<a href="http://www.modbustools.com">www.modbustools.com</a>	Modbus Poll
Power Supply	-	20-24V, 0.5A
Level transmitter	MII	Model 706
Probe	MII	Model 706 compatible

### 4.3. Setup

Connect the HMA to a power supply via the power terminal block. Connect an RS-485 communications cable to the RS-485 terminal block of the HMA, with the Receive/Transmit Data+ A lead (orange) on the positive terminal and the Receive/Transmit Data- B lead (yellow) on the negative terminal. Connect a 120Ω resistor between the two RS-485 terminal block positions. Connect the other end of the cable to a PC which has a Modbus host application.

### 4.4. Procedure

- 4.4.1 Using Procedure 1, ensure that registers 3000 through 3007 of the HMA match the values shown for the Modbus RTU protocol default settings. Refer to Appendix F for the HMA Communication settings. If the settings do not match, double-click on a value that needs to be changed in order to open the Write Single Register dialog, enter the new value, and then click on Send.
- 4.4.2 Ensure that the DIP switches on the HMA are set to 1 == ON (Default Config Mode), 2 == OFF, 3 == ON, 4 == OFF.
- 4.4.3 Remove power from the HMA.
- 4.4.4 Connect the HMA to a Modbus master.
- 4.4.5 Apply power to the HMA
- 4.4.6 Verify that the Modbus master is receiving responses from the HMA (Tx is increasing) and that there are no communication errors being reported.

## 5. Basic Modbus ASCII Communication over RS-485

### 5.1. Purpose

This setup procedure instructs how to configure the HART to Modbus Adaptor (HMA) to support the Modbus ASCII protocol.

### 5.2. Equipment

Item	Manufacturer	Model
HART to Modbus Adaptor	MII	031-2859-001
USB Communications cable	FDTIchip	USB-RS485-WE
Termination resistor	-	120Ω
Modbus host application	<a href="http://www.modbustools.com">www.modbustools.com</a>	Modbus Poll
Power Supply	-	20-24V, 0.5A

### 5.3. Setup

Connect the HMA to a power supply via the power terminal block. Connect an RS-485 communications cable to the RS-485 terminal block of the HMA, with the Receive/Transmit Data+ A lead (orange) on the positive terminal and the Receive/Transmit Data- B lead (yellow) on the negative terminal. Connect a 120Ω resistor between the two RS-485 terminal block positions. Connect the other end of the cable to a PC which has a Modbus host application.

### 5.4. Procedure

- 5.4.1 Using Procedure 1, ensure that registers 3000 through 3007 of the HMA match the values shown for the Modbus ASCII protocol default settings. Refer to Appendix F for the HMA Communication settings. If the settings do not match, double-click on a value that needs to be changed in order to open the Write Single Register dialog, enter the new value, and then click on Send.
- 5.4.2 Change DIP switch 1 to ON. This sets the device to run in the selected communications mode.
- 5.4.3 Cycle the power to the HMA.
- 5.4.4 Verify that the device is not communicating with the Modbus Poll application.
- 5.4.5 Select Connection\Disconnect from the Modbus Poll menu bar.

- 5.4.6 Select Connection\Connect from the menu bar, ensure that the connection settings are as follows, and then click OK. Note that the USB Serial Port setting needs to match the port number for the communication cable that is being used.

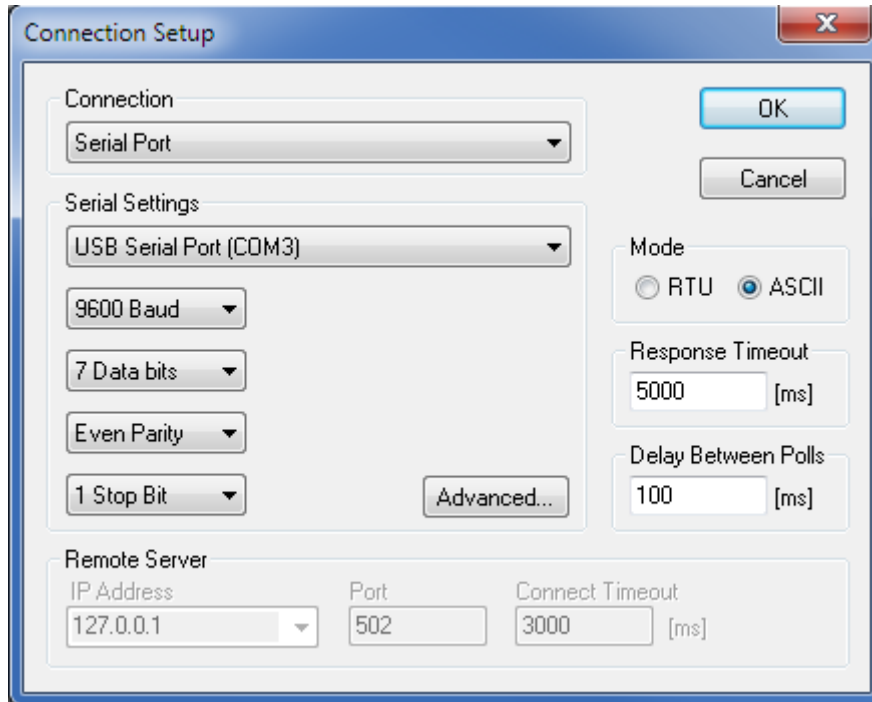

- 5.4.7 Verify that the Modbus Poll application is receiving responses from the HMA (Tx is increasing) and that there are no communication errors being reported.



## 6. Modbus RTU Communication in Single Device Mode

### 6.1. Purpose

This setup procedure instructs how to configure the HART to Modbus Adaptor (HMA), when in the Single Device mode, to support the various parameter registers defined for the attached device.

In the Single Device mode (register 3007 set to 2), the HMA and attached device will appear to be a single native Modbus device to the Modbus RTU/master. This mode is for instances where an HMA is used with a single HART device, and is designed to simplify the configuration and commissioning process. PACTware and a DTM or a HART host with a DD can be used to configure the attached device. When the HART poll address of the device is changed, the HMA will automatically change its Modbus address to match.

### 6.2. Equipment

Item	Manufacturer	Model
HART to Modbus Adaptor	MII	031-2859-001
USB Communications cable	FDTIchip	USB-RS485-WE
Termination resistor	-	120Ω
Modbus host application	<a href="http://www.modbustools.com">www.modbustools.com</a>	Modbus Poll
Power Supply	-	20-24V, 0.5A
Level transmitter	MII	Model 706
Probe	MII	Model 706 compatible

### 6.3. Setup

Connect the HMA to a power supply via the 9-30 VDC terminal block. Connect a HART modem and HART host or a 475 Field Communicator to the HART terminal block.

### 6.4. Procedure

- 6.4.1 Connect the HMA to a power supply and HART host as specified in section 6.3.
- 6.4.2 Using Procedure 2, verify that register 3012 on the HMA is set to a value of 2 – Single Device.
- 6.4.3 Configure the HART device using the HART host.
- 6.4.4 Change the poll address of the HART device to the desired Modbus address (within the range of 0 to 63).
- 6.4.5 Set position 1 of the DIP switch to 1.
- 6.4.6 Cycle power to the HMA.
- 6.4.7 The HMA will search through the 0 to 63 poll range for the attached device. Once the device is found, the HMA will automatically change its Modbus address to match.
- 6.4.8 Note that the Modbus communication settings such as baud rate, parity, etc. require a Modbus master to change the settings. See Procedure 1.

## 7. Modbus RTU Communication in Device Mode

### 7.1. Purpose

This setup procedure instructs how to configure the HART to Modbus Adaptor (HMA), when in the Device mode, to support the various parameter registers defined for the attached devices. It also demonstrates how to use multiple HMAs when it is necessary to communicate with more than five attached HART devices when in the Device mode.

In the Device mode (register 3007 set to 1), the HMA will appear to be transparent to the Modbus RTU/master. The HART poll address of each attached HART unit should be set to the desired Modbus poll address for that device (within the range of 0 to 63). This mode can be useful when several devices are attached to the same RS-485 line. There is no need to maintain a record of which HART device is connected to each HMA device, or to read different register numbers for the same type HART device depending on which slave number it is on which HMA. In effect, the HART devices will appear to the Modbus master as native Modbus devices. For the same type device, the register number for various parameters will be the same from unit to unit. The HMA should have a different Modbus address so that it can also be queried by the Modbus master.

### 7.2. Equipment

Item	Manufacturer	Model
HART to Modbus Adaptor	MII	031-2859-001
USB Communications cable	FDTIchip	USB-RS485-WE
Termination resistor	-	120Ω
Modbus host application	<a href="http://www.modbustools.com">www.modbustools.com</a>	Modbus Poll
Power Supply	-	20-24V, 0.5A
Level transmitter	MII	Model 706
Probe	MII	Model 706 compatible
Level transmitter	MII	Model 705 3x
Probe	MII	Model 705 3x compatible
Level transmitter	MII	Model 355
Level transmitter	MII	Model R82 R2
Level transmitter	MII	Model RX5
Level transmitter	MII	Enhanced Jupiter
Level transmitter	MII	E3 Modulelevel

### 7.3. Setup

Connect two HMAs to a power supply via the power terminal block. Connect an RS-485 communications cable to a PC which has a Modbus host application. Connect the other end of the cable to the RS-485 terminal block of the HMA1. Install jumper wires connecting the positive terminal of the RS-485 terminal block of HMA1 and the positive terminal of the RS-485 terminal block of HMA2 as well as the negative terminal of the two terminal blocks. Connect a 120Ω resistor between the two RS-485 terminal block positions of HMA2. Connect additional supported Magnetrol HART devices to the HART loop terminal block of the two HMAs. There can be any combination of devices including the Model 706, Model 705 3x, Model 355, Model R82 R2, Model RX5, Enhanced Jupiter and E3 Modulelevel device. Note that each device's Poll Address can be set to any value between 0 and 63 as long as it has a unique Poll Address, and

there can be a maximum of 5 devices connected to an HMA including the device in the housing containing the HMA.

#### **7.4. Procedure**

- 7.4.1 Connect the HMAs to a power supply, Modbus host and MII HART transmitters as specified in section 7.3.
- 7.4.2 Temporarily disconnect HMA2.
- 7.4.3 Using Procedure 1, ensure that registers 3000 through 3007 of the HMA match the values shown for the Modbus RTU protocol default settings. Refer to Appendix F for the HMA Communication settings. If the settings do not match, double-click on a value that needs to be changed in order to open the Write Single Register dialog, enter the new value, and then click on Send.
- 7.4.4 Using Procedure 2, change register 3001 to a value of 15. This changes the address of the HMA to 15 to be unique from the other HMA and from the attached devices.
- 7.4.5 Using Procedure 2, change register 3007 to a value of 1. This sets the HMA to run in the Device mode which allows direct Modbus addressing of the HART devices. In this mode, the Modbus address will be the same as the HART Poll Address.
- 7.4.6 Using Procedure 2, change register 3012 to a value of 0. This will cause the HMA to scan the attached devices at start-up, and record the poll address and other information for each device.
- 7.4.7 Repeat steps 6.4.2 through 6.4.6 except disconnecting HMA1 and modifying settings on HMA2. Set the Poll Address of HMA2 to 20.
- 7.4.8 Power down the HMAs, change DIP switch 1 to ON for both units, and then reapply power to both HMAs.
- 7.4.9 Using Procedure 2, verify that register 3012 on each HMA has automatically changed to a value of 1.

7.4.10 Using Procedure 2, verify that parameters of the HART devices can be read through the appropriate registers. The supported parameters of the Magnetrol HART transmitters are listed in Appendices I through O. Use the Modbus Register number column labeled 'Device Mode' for the Address number. Note that the Slave ID number must match the HART Poll Address of the attached device. Multiple registers may be read at the same time as long as the register numbers are contiguous and can be shown as the same data type. For example, the PV, SV, TV and QV values can be displayed in one Modbus Poll window by setting the Read/Write Definition to:

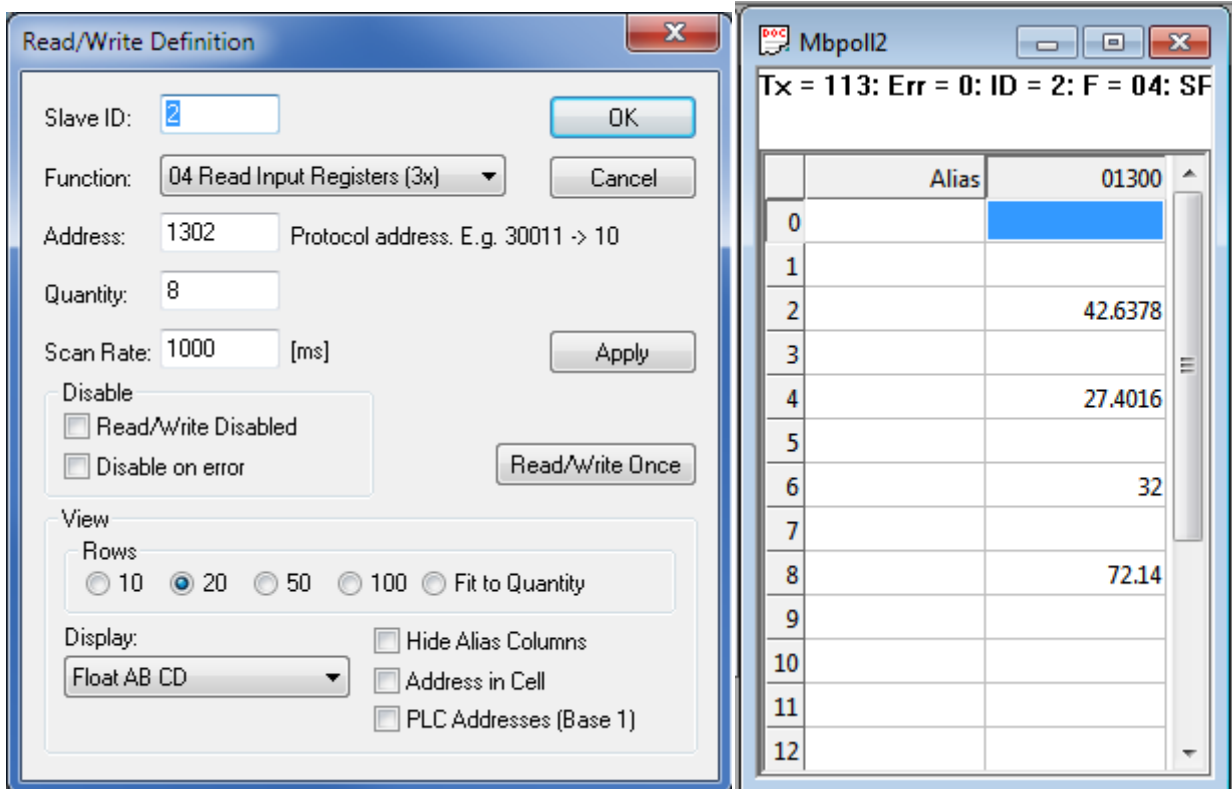

- 7.4.11 Verify that the values displayed match the values shown on the device's local user interface.
- 7.4.12 For parameters that are defined as Holding registers in Appendix I, use Procedure 2 to verify that a value can be written to the device and that the new value appears on the local display of the device. To write a new value to the device, double-click on a value that needs to be changed in order to open the Write Single Register dialog, enter the new value, and then click on Send.
- 7.4.13 Repeat steps 6.4.10 through 6.4.12 for the other devices attached to the HMAs. For each device, the Slave ID entered in step 6.4.10 must match the Poll Address for that device. The supported parameters for a device are listed in Appendices I through O.

## 8. Modbus RTU Communication in HMA Mode

### 8.1. Purpose

This setup procedure instructs how to configure the HART to Modbus Adaptor (HMA), when in the HMA mode, to support the various registers defined for the attached devices. It also demonstrates how to use multiple HMAs when it is necessary to communicate with more than five attached HART devices when in the HMA mode.

In the HMA mode (register 3007 set to 0), the HMA will be the only device directly visible to the Modbus RTU/master. This mode can be useful when more devices are attached to the same RS-485 line than there are available Modbus addresses. With each HMA supporting up to 5 HART devices, far fewer Modbus addresses are required for a given number of HART devices. All commands to read or write to a device are accomplished by using only HMA registers. In effect, the HART devices will be invisible to the Modbus master, and the HMAs will appear to be able to provide multiple level readings. For the same type device, the HMA register number to access various parameters in the attached HART devices will be different from HART device to HART device and will depend on the slave number of the device on the HMA.

### 8.2. Equipment

Item	Manufacturer	Model
HART to Modbus Adaptor	MII	031-2859-001
USB Communications cable	FDTIchip	USB-RS485-WE
Termination resistor	-	120Ω
Modbus host application	<a href="http://www.modbustools.com">www.modbustools.com</a>	Modbus Poll
Power Supply	-	20-24V, 0.5A
Level transmitter	MII	Model 706
Probe	MII	Model 706 compatible
Level transmitter	MII	Model 705 3x
Probe	MII	Model 705 3x compatible
Level transmitter	MII	Model 355
Level transmitter	MII	Model R82 R2
Level transmitter	MII	Model RX5
Level transmitter	MII	Enhanced Jupiter
Level transmitter	MII	E3 Modulelevel

### 8.3. Setup

Connect two HMAs to a power supply via the power terminal block. Connect an RS-485 communications cable to a PC which has a Modbus host application. Connect the other end of the cable to the RS-485 terminal block of the HMA1. Install jumper wires connecting the positive terminal of the RS-485 terminal block of HMA1 and the positive terminal of the RS-485 terminal block of HMA2 as well as the negative terminal of the two terminal blocks. Connect a 120Ω resistor between the two RS-485 terminal block positions of HMA2. Connect additional supported Magnetrol HART devices to the HART loop terminal block of the two HMAs. There can be any combination of devices including the Model 706, Model 705 3x, Model 355, Model R82 R2, Model RX5, Enhanced Jupiter and E3 Modulelevel. Note that each device's Poll Address can be set to any value between 0 and 63 as long as it has a unique address, and there can be a maximum of 5 devices connected to an HMA including the device in the housing containing the HMA.

## 8.4. Procedure

- 8.4.1 Connect the HMAs to a power supply, Modbus host and MII HART transmitters as specified in section 8.3.
- 8.4.2 Temporarily disconnect HMA2.
- 8.4.3 Using Procedure 1, ensure that registers 3000 through 3007 of the HMA match the values shown for the Modbus RTU protocol default settings. Refer to Appendix F for the HMA Communication settings. If the settings do not match, double-click on a value that needs to be changed in order to open the Write Single Register dialog, enter the new value, and then click on Send.
- 8.4.4 Using Procedure 2, change register 3001 to a value of 15. This changes the address of the HMA to 15 to be unique from the other HMA and from the attached devices.
- 8.4.5 Change register 3007 to a value of 0. This sets the HMA to run in the HMA mode in which only the HMAs are directly addressed by the Modbus master.
- 8.4.6 Change register 3012 to a value of 0. This will cause the HMA to scan the attached devices at start-up, and record the poll address and other information for each device.
- 8.4.7 Repeat steps 7.4.2 through 7.4.6 except disconnecting HMA1 and modifying settings on HMA2. Set the Poll Address of HMA2 to 20.
- 8.4.8 Power down the HMAs, change DIP switch 1 to ON for both units, and then reapply power to both HMAs.
- 8.4.9 Verify that register 3012 on each HMA has automatically changed to a value of 1.
- 8.4.10 Verify that register 1250 on each HMA displays the correct number of attached devices.

8.4.11 Check that the Device Type (1251 – 1255) and Polling Address (1256 – 1260) registers display the correct values for the attached devices. All eight registers along with register 1250 can be displayed in one Mbpoll window if the Display parameter is set to 'Hex' in the Read/Write Definition dialog. Refer to Appendix H for the register numbers. For example, with two devices attached:

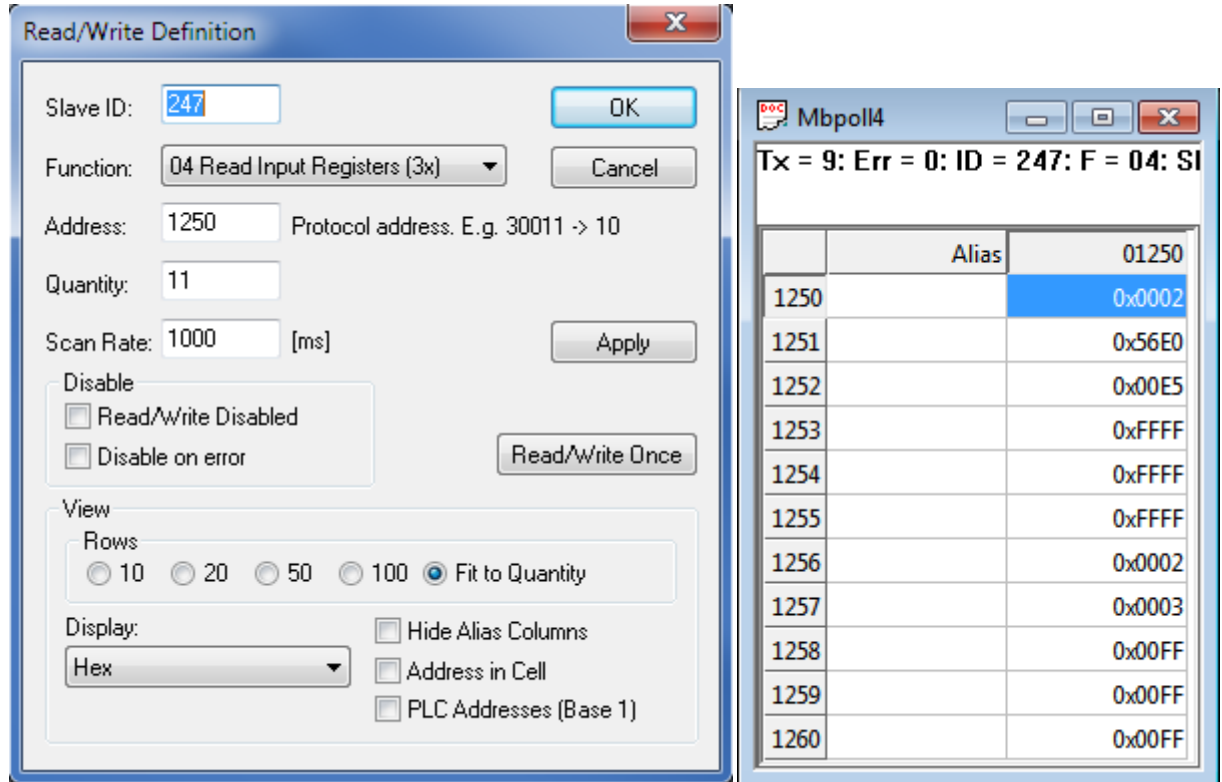

8.4.12 Note that Poll Address and Device Type registers corresponding to Slave IDs with no attached device will show 0xFFFF and 0x00FF respectively.

8.4.13 Open a new Mbpoll window.

8.4.14 The supported parameters for the HART devices are listed in Appendices I through O. For each device, use the appropriate table and the Modbus Register number column labeled with the Slave ID number of the device. Read the registers for each parameter. Note that the Slave ID number for the Mbpoll window must match the Slave ID of the HMA, not the attached device. For example, to read the PV through QV values for Slave ID 2, set the Read/Write Definition to:

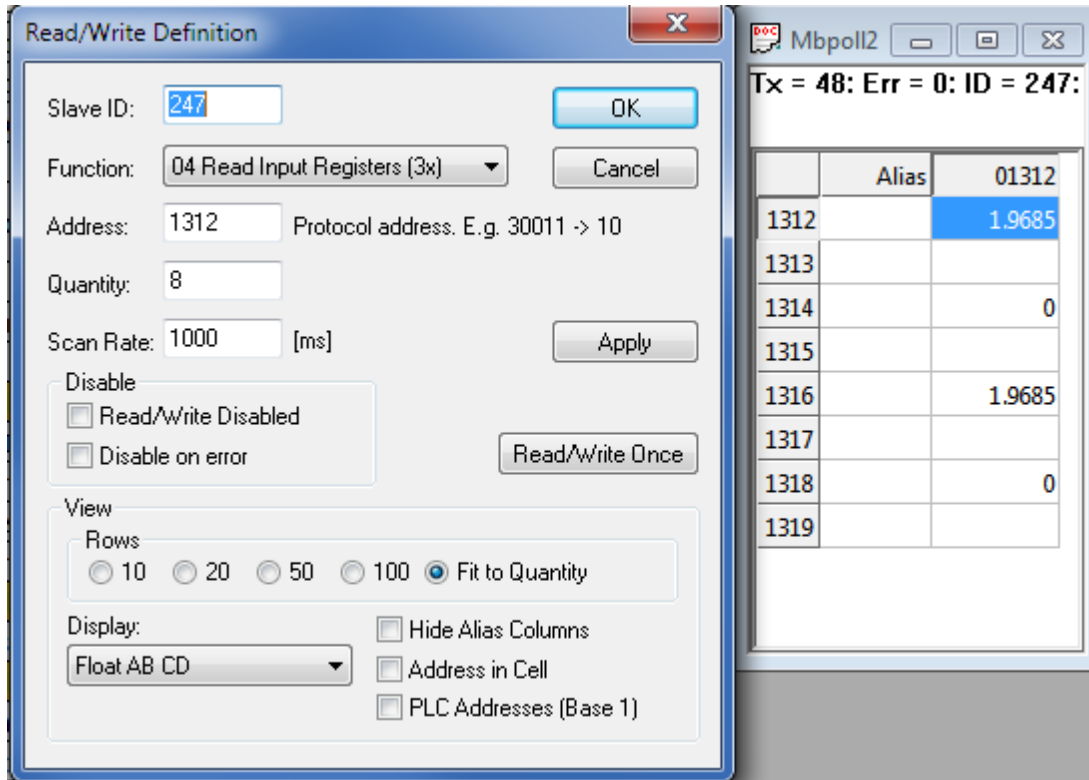

- 8.4.15 Ensure that the values displayed match the values shown on the device's local user interface.
- 8.4.16 Repeat steps 7.4.14 and 7.4.15 for the remaining parameters listed in Appendices I through O for the attached devices.
- 8.4.17 For parameters that are defined as Holding registers in Appendix I, ensure that a value can be written to the device and that the new value appears on the local display of the device. To write a new value to the device, double-click on a value that needs to be changed in order to open the Write Single Register dialog, enter the new value, and then click on Send.
- 8.4.18 Repeat steps 7.4.11 through 7.4.17 for HMA2 (Slave address 20).



## 9. Basic LevelMaster Communication

### 9.1. Purpose

This setup procedure instructs how to configure the HART to Modbus Adaptor (HMA) to support the Modbus LevelMaster protocol.

In the LevelMaster configuration, the HMA will appear to be invisible to the LevelMaster host. This is due to the limited command set available with LevelMaster. Instead, the attached HART devices will appear to be native LevelMaster devices. They will respond to the Modbus poll address equivalent to their HART poll address. The devices will return the HART PV and SV as the two D (float) values in the Uxx? command response. The F value corresponds to the Echo Signal strength. The E and W values correspond to the highest active Error and Warning diagnostic in each category.

### 9.2. Equipment

Item	Manufacturer	Model
HART to Modbus Adaptor	MII	031-2859-001
USB Communications cable	FDTIchip	USB-RS485-WE
Termination resistor	-	120Ω
Modbus host application	<a href="http://www.modbustools.com">www.modbustools.com</a>	Modbus Poll
Terminal v1.9b application	<a href="http://hw-server.com">hw-server.com</a>	Version 1.9b - 20040204
Power Supply	-	20-24V, 0.5A
Level transmitter	MII	Model 706
Probe	MII	Model 706 compatible

### 9.3. Setup

Connect the HMA to a power supply via the power terminal block. Connect an RS-485 communications cable to the RS-485 terminal block of the HMA, with the Receive/Transmit Data+ A lead (orange) on the positive terminal and the Receive/Transmit Data- B lead (yellow) on the negative terminal. Connect a 120Ω resistor between the two RS-485 terminal block positions. Connect the other end of the cable to a PC which has a Modbus host application. Connect a Model 706 level transmitter to the HART loop terminal block of the HMA. Set the HART Poll Address of the Model 706 device to 2. Note that other Magnetrol HART transmitters and HART poll addresses can be used.

### 9.4. Procedure

- 9.4.1 Connect the HMA to a power supply, Modbus host and Model 706 HART transmitter as specified in section 9.3.
- 9.4.2 Using Procedure 1, ensure that registers 3000 through 3007 of the HMA match the values shown for the Modbus LevelMaster protocol default settings. Refer to Appendix F for the HMA Communication settings. If the settings do not match, double-click on a value that needs to be changed in order to open the Write Single Register dialog, enter the new value, and then click on Send.

- 9.4.3 Change register 3012 to a value of 0. This will cause the HMA to scan the attached devices at start-up, and record the poll address and other information for each attached HART device.

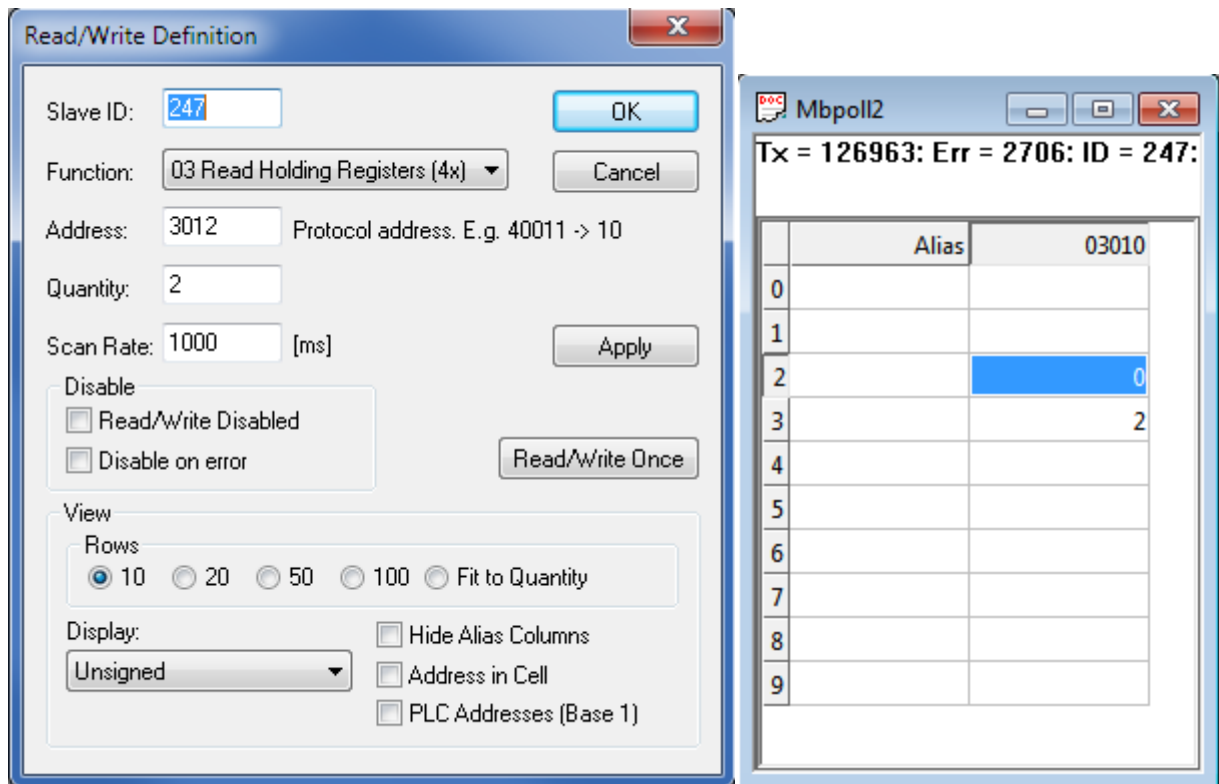

- 9.4.4 Power down the HMA, change DIP switch 1 to ON, and reapply power to the HMA.
- 9.4.5 Select Connection\Disconnect from the menu bar.
- 9.4.6 Start the Terminal v1.9b application. Note that any similar application that supports transmission/reception of ASCII characters over the RS-485 connection may be used.
- 9.4.7 Set the COM Port to match the COM port used for the communication cable (the same number as with the Modbus Poll application).
- 9.4.8 Set the Baud rate, Data bits, Parity, Stop Bits and Handshaking parameters to match the settings made in the HMA for LevelMaster communication.

9.4.9 The Terminal application settings should be as below.

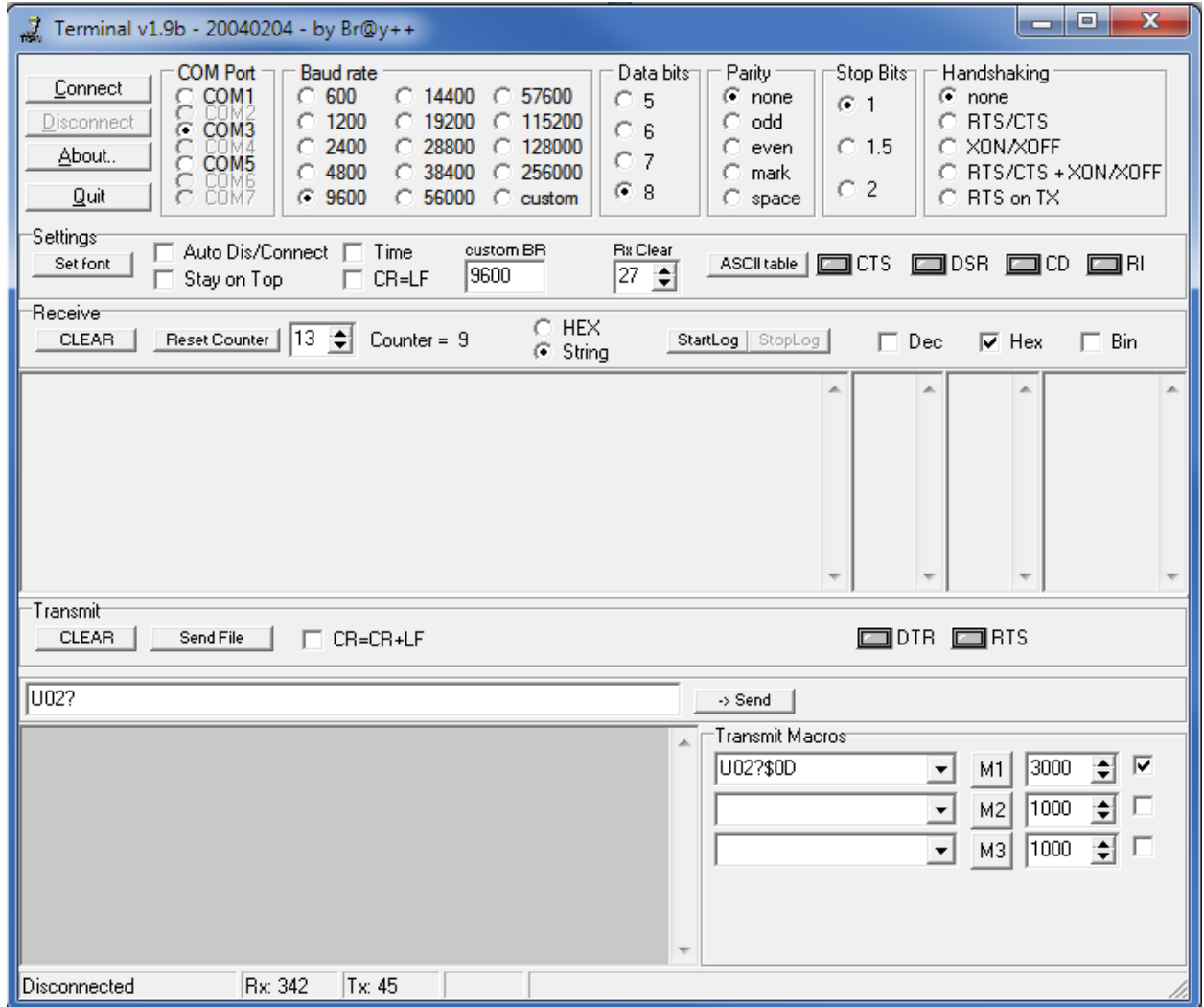

9.4.10 Click Connect.

9.4.11 Create a Transmit Macro that will send U02?\$0D and check the checkbox to the right of the macro definition. Note that the 02 in the macro represents the Poll Address of the Model 706 device.

9.4.12 Verify that the Terminal application is receiving responses from the HMA and that there are no communication errors being reported. The Receive buffer section should have the same number of responses as the Transmit buffer section.

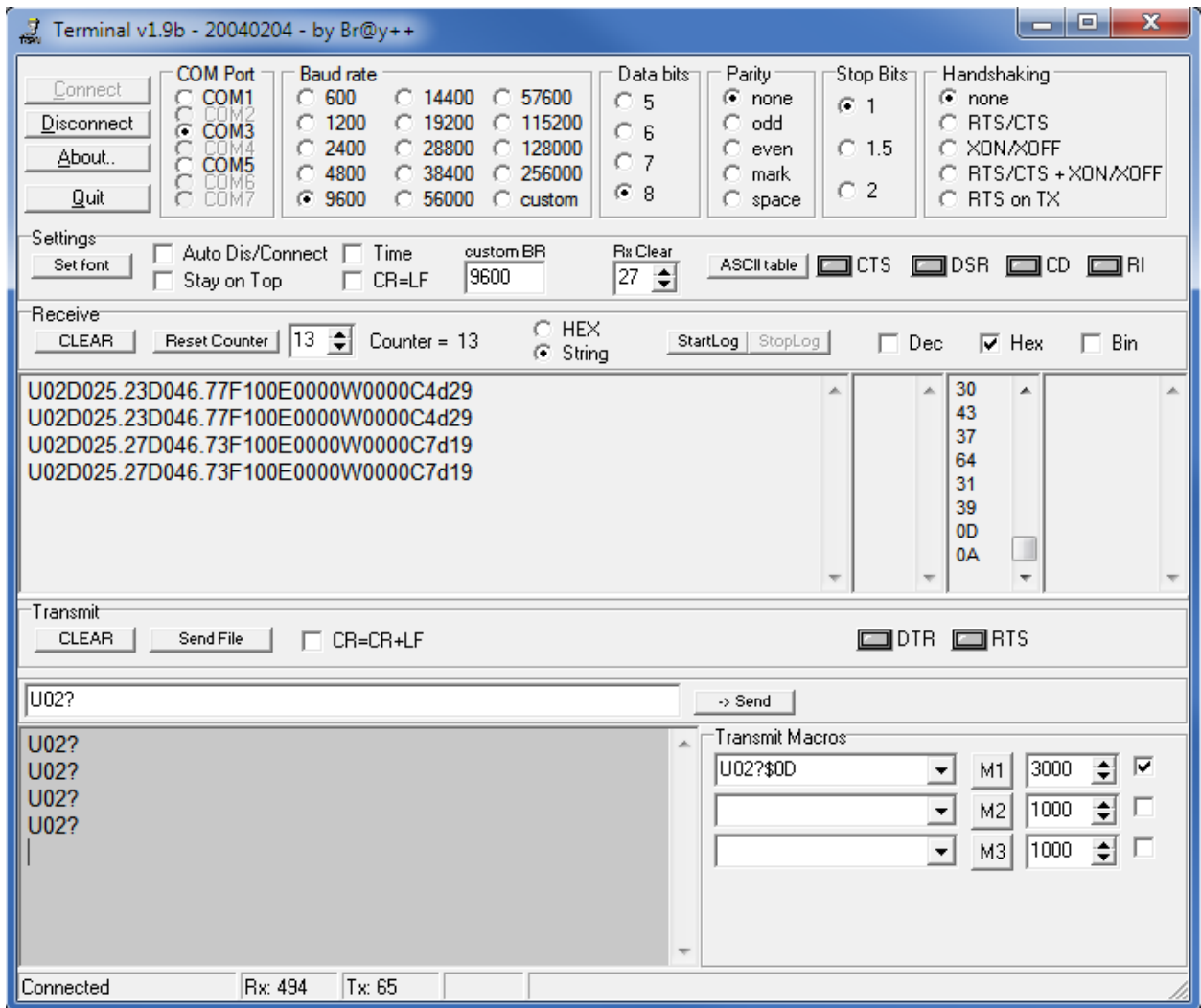

- 9.4.13 Verify that the value after the U in the response matches the Poll Address of the Model 706 device.
- 9.4.14 Verify that the value after the first D in the response matches the PV value shown on the local display of the Model 706 device.
- 9.4.15 Verify that the value after the second D in the response matches the SV value shown on the local display of the Model 706 device.
- 9.4.16 Verify that the value after the F in the response matches the Echo Strength value shown on the local display of the Model 706 device.
- 9.4.17 Verify that the values after the E and W in the response match the highest priority of any active diagnostics in the attached device. See Appendix P for a listing of codes. Typically, the code should match the active diagnostic displayed on the device's LCD home screen.

## 10. Additional LevelMaster Commands

### 10.1. Purpose

This setup procedure instructs how to configure the HART to Modbus Adaptor (HMA) to support the additional Modbus LevelMaster protocol commands implemented in the HMA.

Using this procedure, the Number of Floats (UxxF?) can be read from the attached HART device and the Level Offset parameter can be read (UxxOL?) and changed (UxxOLxxxx?).

Note that the returned value for Level Offset, as well as the value for writing to the device, is multiplied by a factor of 10. For instance, a value of 0015 in the UxxOL? command represents a value of 1.5 in the HART device. This is to allow a more precise adjustment capability within the context of the command being limited to whole numbers.

### 10.2. Equipment

Item	Manufacturer	Model
HART to Modbus Adaptor	MII	031-2859-001
USB Communications cable	FDTIchip	USB-RS485-WE
Termination resistor	-	120Ω
Modbus host application	<a href="http://www.modbustools.com">www.modbustools.com</a>	Modbus Poll
Terminal v1.9b application	<a href="http://hw-server.com">hw-server.com</a>	Version 1.9b - 20040204
Power Supply	-	20-24V, 0.5A
Level transmitter	MII	Model 706
Probe	MII	Model 706 compatible

### 10.3. Setup

Connect the HMA to a power supply via the power terminal block. Connect an RS-485 communications cable to the RS-485 terminal block of the HMA, with the Receive/Transmit Data+ A lead (orange) on the positive terminal and the Receive/Transmit Data- B lead (yellow) on the negative terminal. Connect a 120Ω resistor between the two RS-485 terminal block positions. Connect the other end of the cable to a PC which has a Modbus host application. Connect a Model 706 level transmitter to the HART loop terminal block of the HMA. Set the HART Poll Address of the Model 706 device to 3. Note that other Magnetrol HART transmitters and HART poll addresses can be used.

### 10.4. Procedure

- 10.4.1 The HMA shall be connected to a power supply, Modbus host and Model 706 HART transmitter as specified in section 10.3.
- 10.4.2 Using Procedure 1, ensure that registers 3000 through 3007 of the HMA match the values shown for the Modbus LevelMaster protocol default settings. Refer to Appendix F for the HMA Communication settings. If the settings do not match, double-click on a value that needs to be changed in order to open the Write Single Register dialog, enter the new value, and then click on Send.

- 10.4.3 Change register 3012 to a value of 0. This will cause the HMA to scan the attached devices at start-up, and record the poll address and other information for each device.

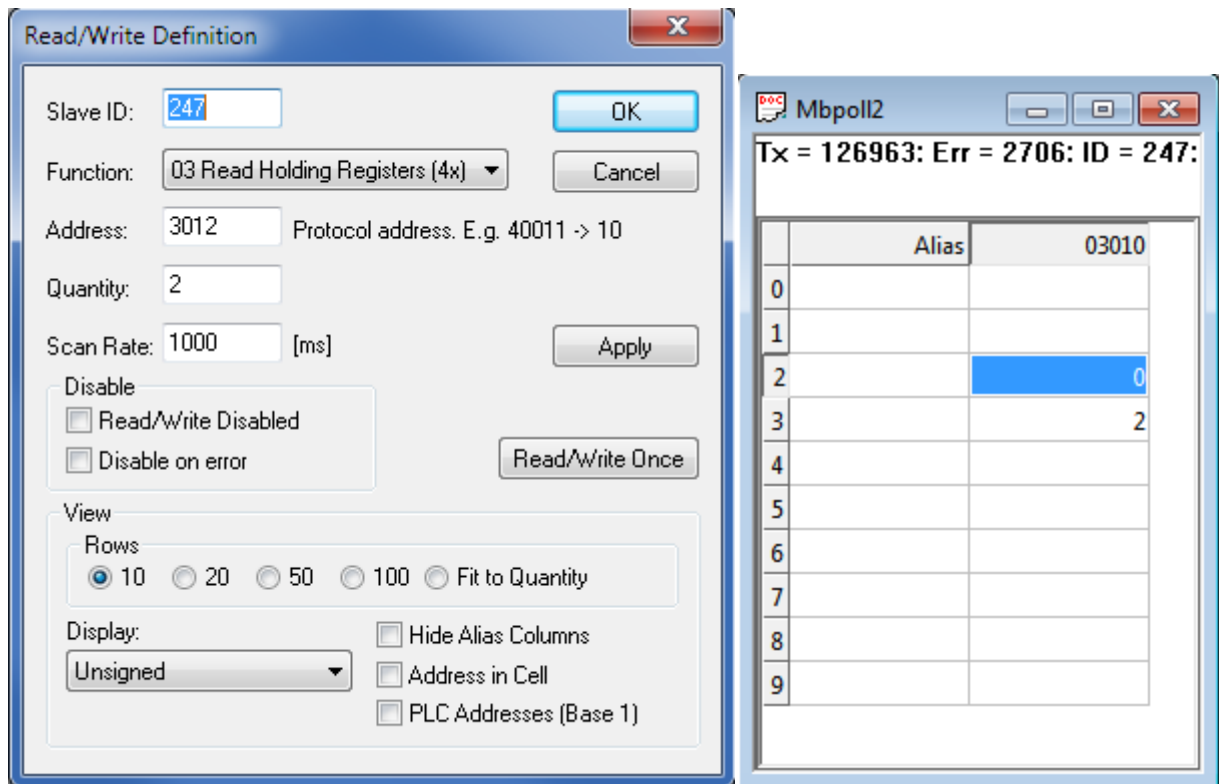

- 10.4.4 Power down the HMA, change DIP switch 1 to ON, and reapply power to the HMA.
- 10.4.5 Select Connection\Disconnect from the Modbus Poll menu bar.
- 10.4.6 Start the Terminal v1.9b application.
- 10.4.7 Set the COM Port to match the COM port used for the communication cable (the same number as with the Modbus Poll application).
- 10.4.8 Set the Baud rate, Data bits, Parity, Stop Bits and Handshaking parameters to match the settings made in the HMA for LevelMaster communication.
- 10.4.9 Click Connect.

- 10.4.10 Create a Transmit Macro that will send U03F?\$0D and click on the Mx button to the right of the macro definition. This command requests the number of floats that the attached device will return when responding to the Uxx? command. For the HMA implementation, there will always be two floats returned so '2' should always be returned by the UxxF? Command. Note that the 03 in the macro represents the Poll Address of the Model 706 device.
- 10.4.11 Verify that the Terminal application receives a response from the HMA each time the Mx button is clicked, and that there are no communication errors being reported. The Receive buffer section should have the same number of responses as the Transmit buffer section.

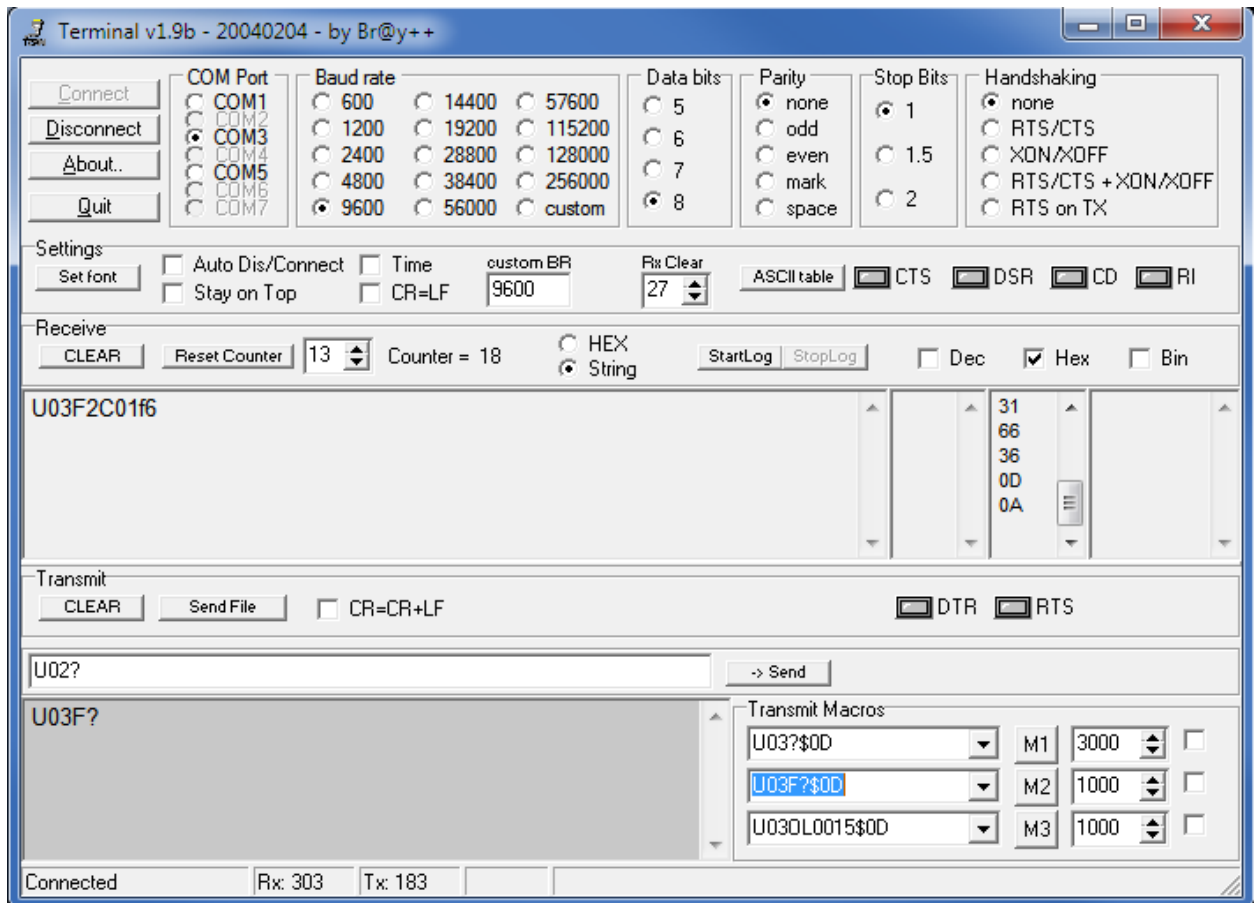

- 10.4.12 Verify that the value after the F in the response equals two.

- 10.4.13 Create a Transmit Macro that will send U03OL?\$0D and click on the Mx button to the right of the macro definition. This command requests the value for Level Offset in the attached device. Note that the 03 in the macro represents the Poll Address of the Model 706 device.
- 10.4.14 Verify that the Terminal application receives a response from the HMA each time the Mx button is clicked, and that there are no communication errors being reported. The Receive buffer section should have the same number of responses as the Transmit buffer section.

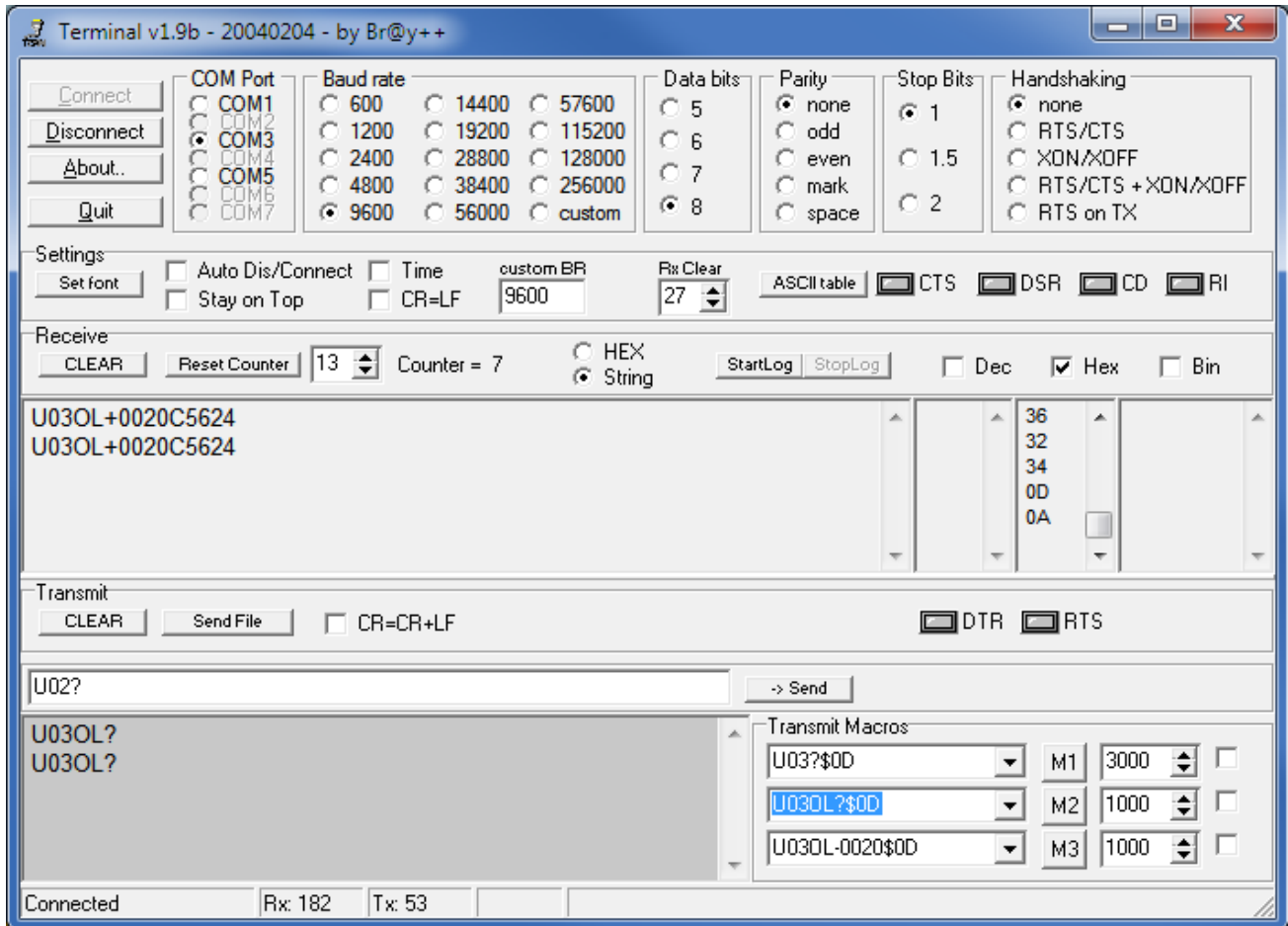

- 10.4.15 Verify that the value after the OL in the response matches the Level Offset value shown on the local display of the Model 706 device. The value displayed is shown as a whole number to conform to the command requirements, but actually represents the Level Offset multiplied by 10. For example, a Level Offset of 1.5 inches will be displayed in the command response as 0015. The value returned by the command may vary from the value shown on the local display by a value of 1 due to the effects of rounding. The value returned will be in terms of Level Units.



- 10.4.16 Create a Transmit Macro that will send U03OL0020\$0D and click on the Mx button to the right of the macro definition. This command requests that the sent value be saved for Level Offset in the attached device. The value is in terms of Level Units.
- 10.4.17 Verify that the Terminal application receives a response from the HMA each time the Mx button is clicked, and that there are no communication errors being reported. The Receive buffer section should have the same number of responses as the Transmit buffer section.

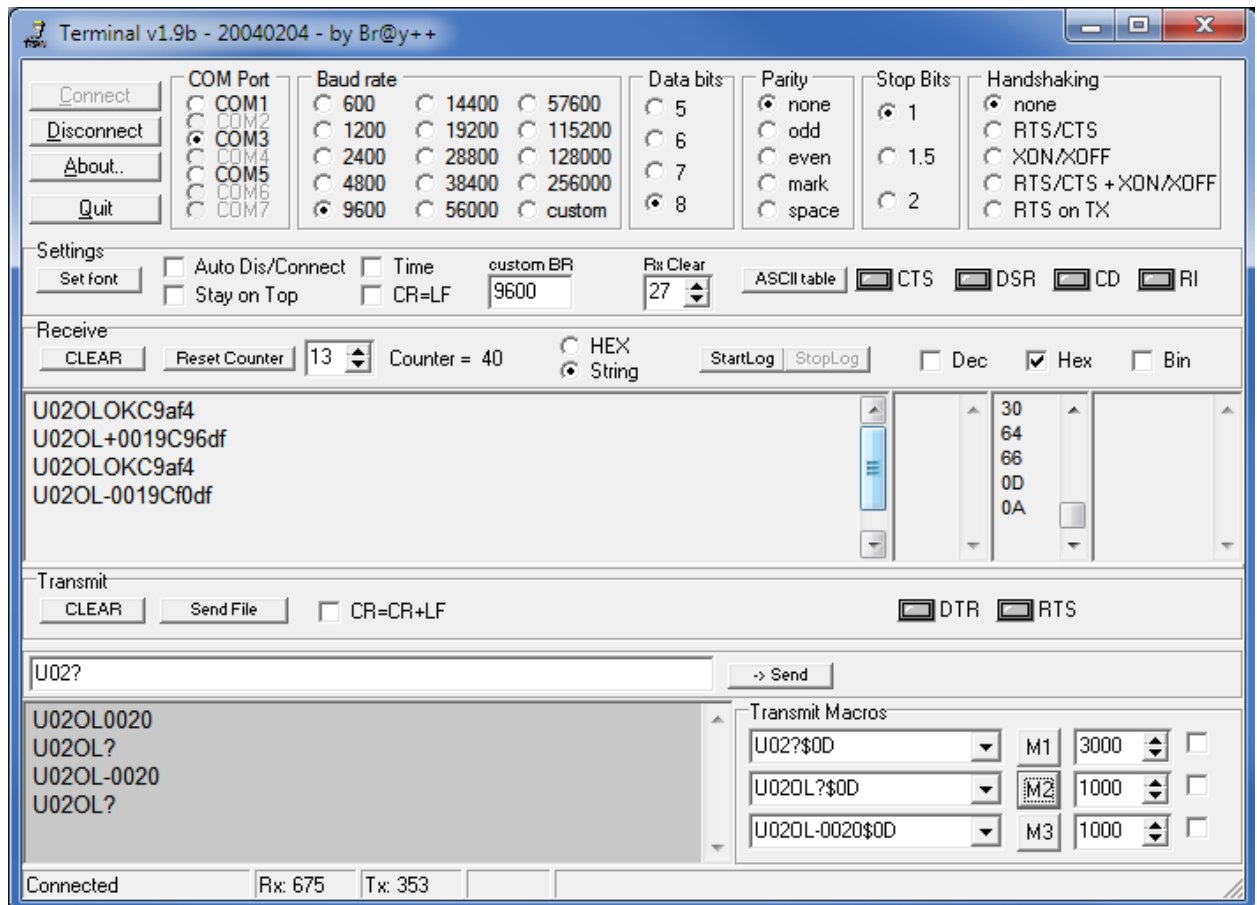

- 10.4.18 Verify that the value after the OL in the response to command U03OL?\$0D matches the Level Offset value sent by the U03OL0020\$0D command and shown on the local display of the Model 706 device. The value returned by command U03OL?\$0D may vary from the value shown on the local display by a value of 1 due to the effects of rounding.
- 10.4.19 Repeat steps 10.4.16 through 10.4.18 while sending U03OL-0020\$0D to cause a write of -2.0 as the Level Offset.

## 11. Auto Switching Between Modbus RTU/ASCII and HART over RS-485 Communication

### 11.1. Purpose

This setup procedure instructs how to configure the HART to Modbus Adaptor (HMA) to automatically switch between Modbus RTU and HART over RS-485 communication when it receives the appropriate commands.

This provides a convenient method for configuring or troubleshooting an attached HART device using PACTware. The process is to set a register to a value of 1 while the HMA is in a Modbus communication mode. The HMA will automatically switch to the HART over RS-485 mode. No cycling of power is required. PACTware can then be connected to a device through the RS-485 terminal block on the HMA. Once the PACTware session is completed, by sending a HART command 0 with a poll address of 63, a user can cause the HMA to automatically revert to the previous Modbus configuration protocol settings. Again, no cycling of power is required.

This procedure demonstrates the auto-switching feature using the Modbus RTU protocol. The process can be used for the Modbus ASCII protocol by setting the HMA for that protocol in step 11.4.2.

### 11.2. Equipment

Item	Manufacturer	Model
HART to Modbus Adaptor	MII	031-2859-001
USB Communications cable	FDTIchip	USB-RS485-WE
Termination resistor	-	120Ω
Modbus host application	<a href="http://www.modbustools.com">www.modbustools.com</a>	Modbus Poll
Power Supply	-	20-24V, 0.5A
PACTware	PACTware Consortium	Version 4.1 or higher
Level transmitter	MII	Model 706
Probe	MII	Model 706 compatible

### 11.3. Setup

Connect the HMA to a power supply via the power terminal block. Connect an RS-485 communications cable to the RS-485 terminal block of the HMA, with the Receive/Transmit Data+ A lead (orange) on the positive terminal and the Receive/Transmit Data- B lead (yellow) on the negative terminal. Connect a 120Ω resistor between the two RS-485 terminal block positions. Connect the other end of the cable to a PC which has a Modbus host application. Connect a Model 706 transmitter and probe, or other supported Magnetrol HART transmitter, to the HART loop terminal block of the HMA. The device's Poll Address can be set to any value between 0 and 14.

### 11.4. Procedure

- 11.4.1 Connect the HMA to a power supply and Modbus as specified in section 11.3.
- 11.4.2 Using Procedure 1, ensure that registers 3000 through 3007 of the HMA match the values shown for the Modbus RTU protocol default settings. Refer to Appendix F for the HMA Communication settings. If the settings do not match, double-click on a value that needs to be changed in order to open the Write Single Register dialog, enter the new value, and then click on Send.

- 11.4.3 Note that when the HMA is in the Single Device Mode (register 3012 set to 2), the HMA address shown in register 3001 will match the HART Poll Address of the attached HART device.
- 11.4.4 Power down the HMA, change DIP switch 1 to ON, and reapply power to the HMA.
- 11.4.5 Click on the Mbpoll window, select Setup\Read\Write Definition from the menu bar, change the Slave ID to match the address shown in step 11.4.3 for register 3012, and then click OK.
- 11.4.6 Verify that the Modbus Poll application is communicating with the HMA.
- 11.4.7 Change to value of register 3008 to 1. This causes the HMA to automatically reboot into the HART over RS-485 mode.
- 11.4.8 Verify that the HMA is not communicating with the Modbus Poll application.
- 11.4.9 Select Connection\Disconnect from the Modbus Poll menu bar.
- 11.4.10 Start PACTware.
- 11.4.11 Add a HART Comm DTM to the Project.
- 11.4.12 Left click on the Comm DTM in the Project tree and add a DTM to the Project for one of the listed devices.
- 11.4.13 Right-click on the Comm DTM Project item and select Parameter. Select the correct COM port for the RS-485 communications cable, set the Start address and End address to cover the range of addresses for the attached devices. Set the Comm DTM to be a secondary master, then click OK.
- 11.4.14 Right-click on the Comm DTM Project item and select Additional functions\Change dtm address. Click on the Change address button. Select the poll address number corresponding to the attached Model 706 device, then click Close.
- 11.4.15 Right-click on the Comm DTM Project item and select Connect.
- 11.4.16 Right-click on the Comm DTM Project item and select Additional functions\Change device address. The DTM will scan for attached devices and display them in a list. If necessary, click on the Refresh button.
- 11.4.17 Verify that the attached Model 706 is listed and is shown with the correct Poll Address.
- 11.4.18 Right-click on the Comm DTM Project item and select Connect.
- 11.4.19 Double click on the device entry in the Project tree to open the Online parameterization window.
- 11.4.20 Verify that the DTM communicates with the device and features such as changing parameters and viewing Echo Curves, Echo History (as appropriate) and Trend Data are operational.
- 11.4.21 Close the Online parameterization window.
- 11.4.22 Right-click on the Comm DTM Project item and select Disconnect.
- 11.4.23 Right-click on the Comm DTM Project item and select Parameter. Set both the Start address and End address to 63, then click OK.
- 11.4.24 Right-click on the Comm DTM Project item and select Connect.

- 11.4.25 Right-click on the Comm DTM Project item and select Additional functions\Scan list. The DTM will scan for attached device, sending a HART Command 0 with an address of 63. Receipt of that command by the HMA will cause it to reboot into the Normal operating mode.
- 11.4.26 Shut down PACTware.
- 11.4.27 Open the Modbus Poll application.
- 11.4.28 Select Connection\Connect from the Modbus Poll menu bar, ensure that the connection settings are as follows, and then click OK. Note that the USB Serial Port setting needs to match the port number for the communication cable that is being used.

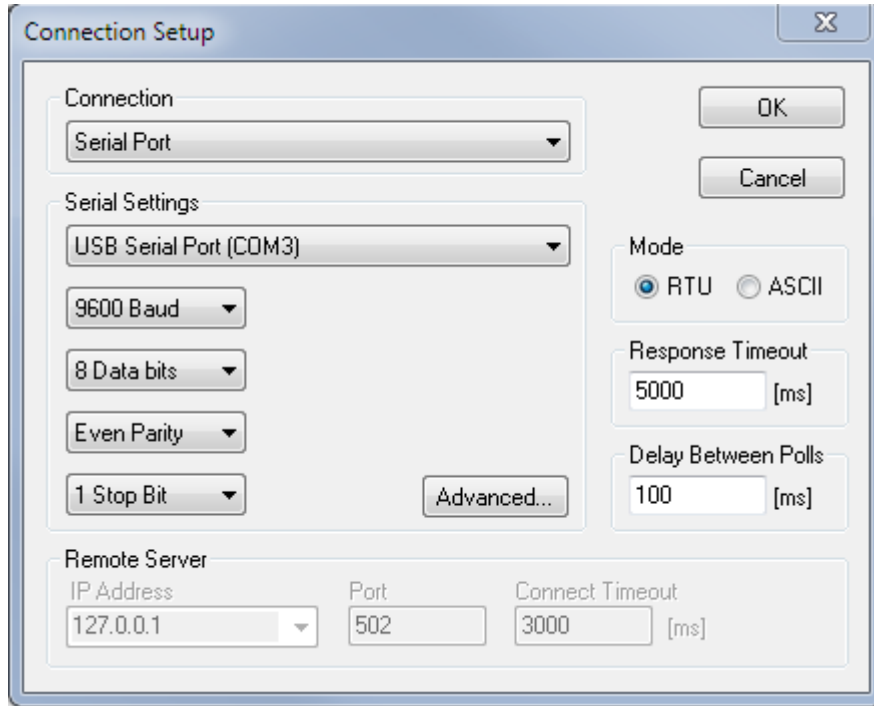

- 11.4.29 Open or click on an Mbpoll window, select Setup\Read\Write Definition from the menu bar, ensure that the settings are as follows, and then click OK:

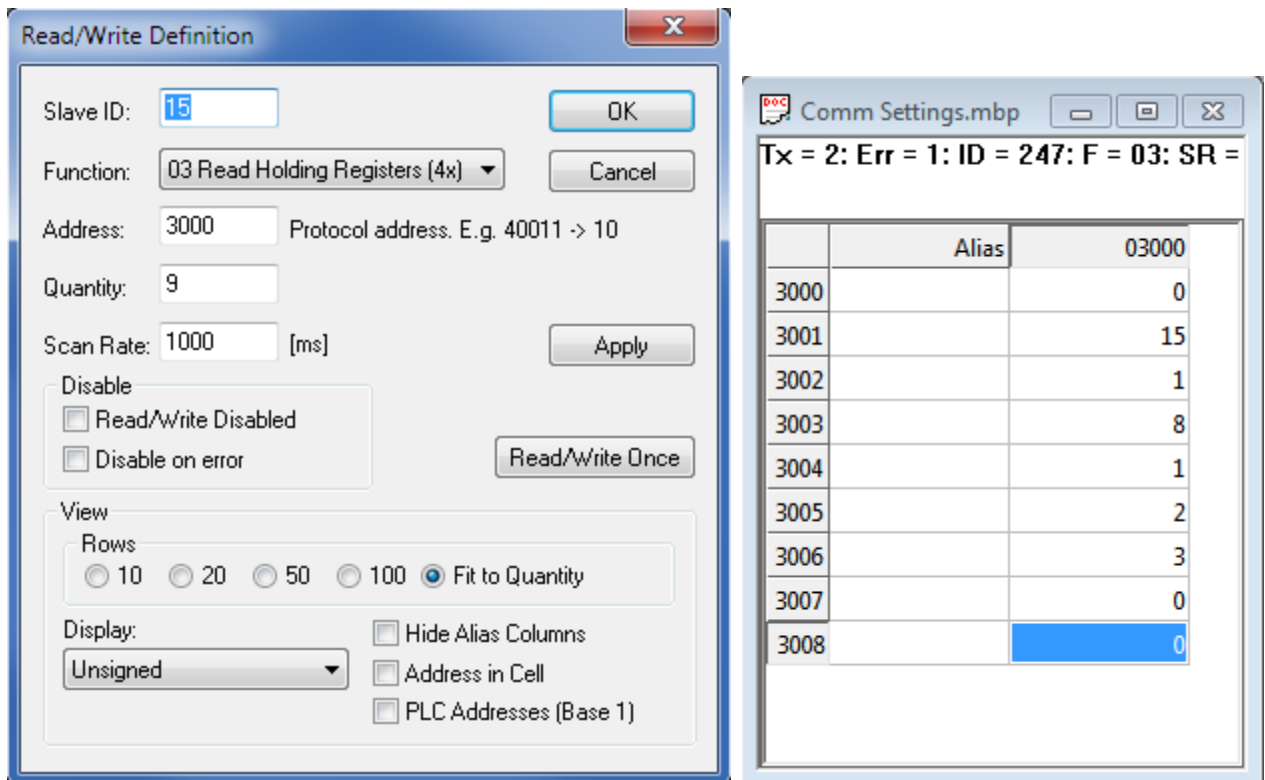

- 11.4.30 Verify that the Tx count in the Mbpoll window is increasing, the Err count is not increasing and there are no reported communication errors.
- 11.4.31 Verify that register 3008 is set to 0.
- 11.4.32 If unable to establish communication in the HART over RS-485 mode, the HMA can be reset to normal Modbus operating mode by switching DIP switch 1 to OFF, and cycling power to the unit. The HMA will power up into the default communication mode. Using Procedure 1, set register 1 to 0. The HMA can be used either in that mode, or by setting DIP switch 1 to ON and cycling power, it can be used in its normal Modbus configuration mode.

## 12. Auto Switching Between LevelMaster and HART over RS-485 Communication

### 12.1. Purpose

This setup procedure instructs how to configure the HART to Modbus Adaptor (HMA) to automatically switch between Modbus and HART over RS-485 communication when it receives the appropriate commands.

### 12.2. Equipment

Item	Manufacturer	Model
HART to Modbus Adaptor	MII	031-2859-001
USB Communications cable	FDTIchip	USB-RS485-WE
Termination resistor	-	120Ω
Modbus host application	<a href="http://www.modbustools.com">www.modbustools.com</a>	Modbus Poll
Terminal v1.9b application	<a href="http://hw-server.com">hw-server.com</a>	Version 1.9b - 20040204
Power Supply	-	20-24V, 0.5A
PACTware	PACTware Consortium	Version 4.1 or higher
Level transmitter	MII	Model 706
Probe	MII	Model 706 compatible

### 12.3. Setup

Connect the HMA to a power supply via the power terminal block. Connect an RS-485 communications cable to the RS-485 terminal block of the HMA, with the Receive/Transmit Data+ A lead (orange) on the positive terminal and the Receive/Transmit Data- B lead (yellow) on the negative terminal. Connect a 120Ω resistor between the two RS-485 terminal block positions. Connect the other end of the cable to a PC which has a Modbus host application. Connect a Model 706 transmitter and probe, or other supported Magnetrol HART transmitter, to the HART loop terminal block of the HMA. The device's Poll Address can be set to any value between 0 and 14.

### 12.4. Procedure

- 12.4.1 Connect the HMA to a power supply, Modbus host and Model 706 HART transmitter as specified in section 12.3.
- 12.4.2 Using Procedure 1, ensure that registers 3000 through 3007 of the HMA match the values shown for the Modbus LevelMaster protocol default settings. Refer to Appendix F for the HMA Communication settings. If the settings do not match, double-click on a value that needs to be changed in order to open the Write Single Register dialog, enter the new value, and then click on Send.
- 12.4.3 Power down the HMA, change DIP switch 1 to ON, and reapply power to the HMA.
- 12.4.4 Ensure that the Modbus Poll application is communicating with the HMA.
- 12.4.5 Select Connection\Disconnect from the Modbus Poll menu bar.
- 12.4.6 Start the Terminal v1.9b application.
- 12.4.7 Set the COM Port to match the COM port used for the communication cable (the same number as with the Modbus Poll application).

- 12.4.8 Set the Baud rate, Data bits, Parity, Stop Bits and Handshaking parameters to match the settings made in the HMA for LevelMaster communication.
- 12.4.9 The Terminal application settings should be as below.

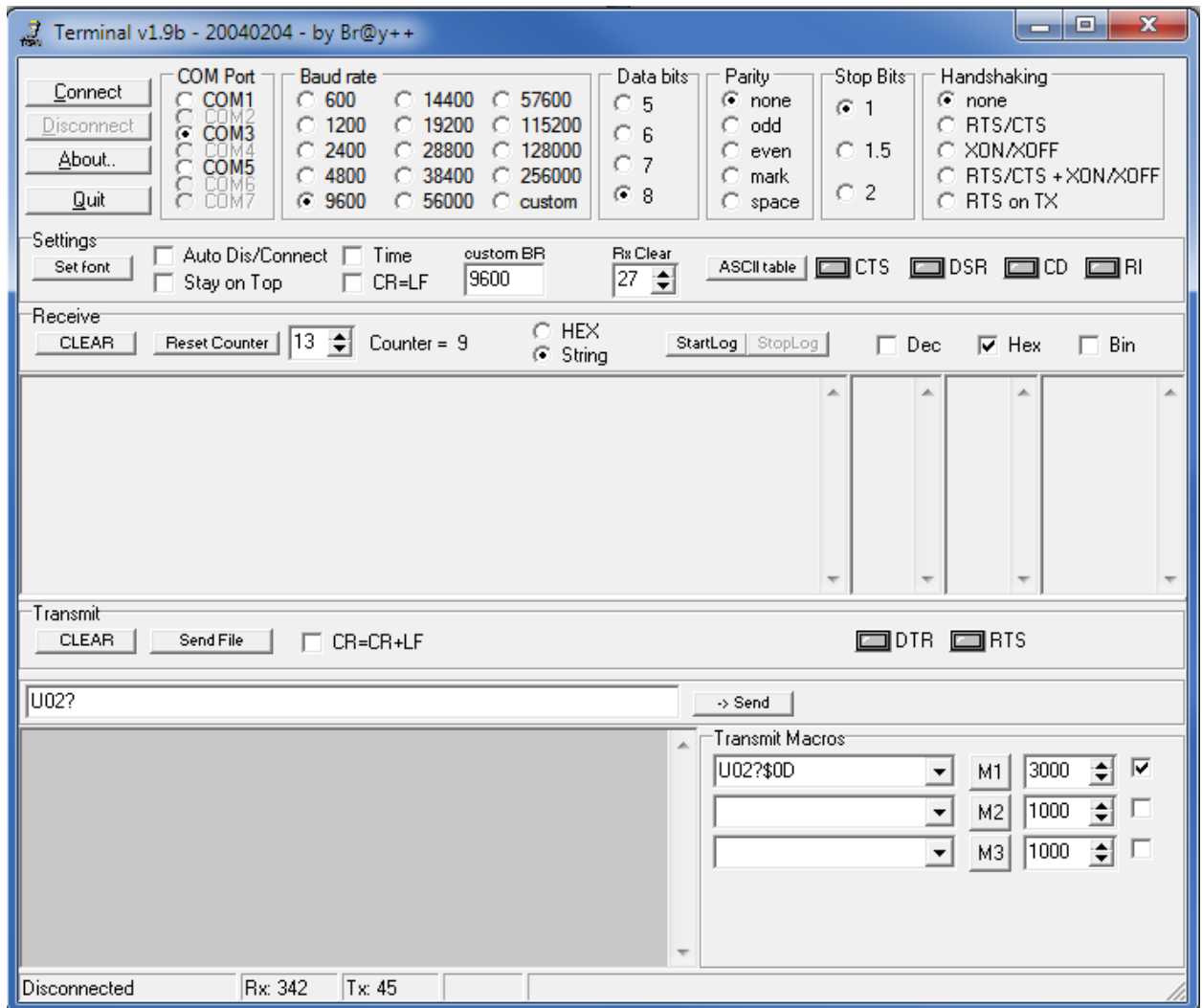

- 12.4.10 Click Connect.
- 12.4.11 Create a Transmit Macro that will send U02?\$0D and check the checkbox to the right of the macro definition. Note that the 02 in the macro represents the Poll Address of the Model 706 device.
- 12.4.12 Verify that the Terminal application is receiving responses from the HMA and that there are no communication errors being reported. The Receive buffer section should have the same number of responses as the Transmit buffer section.

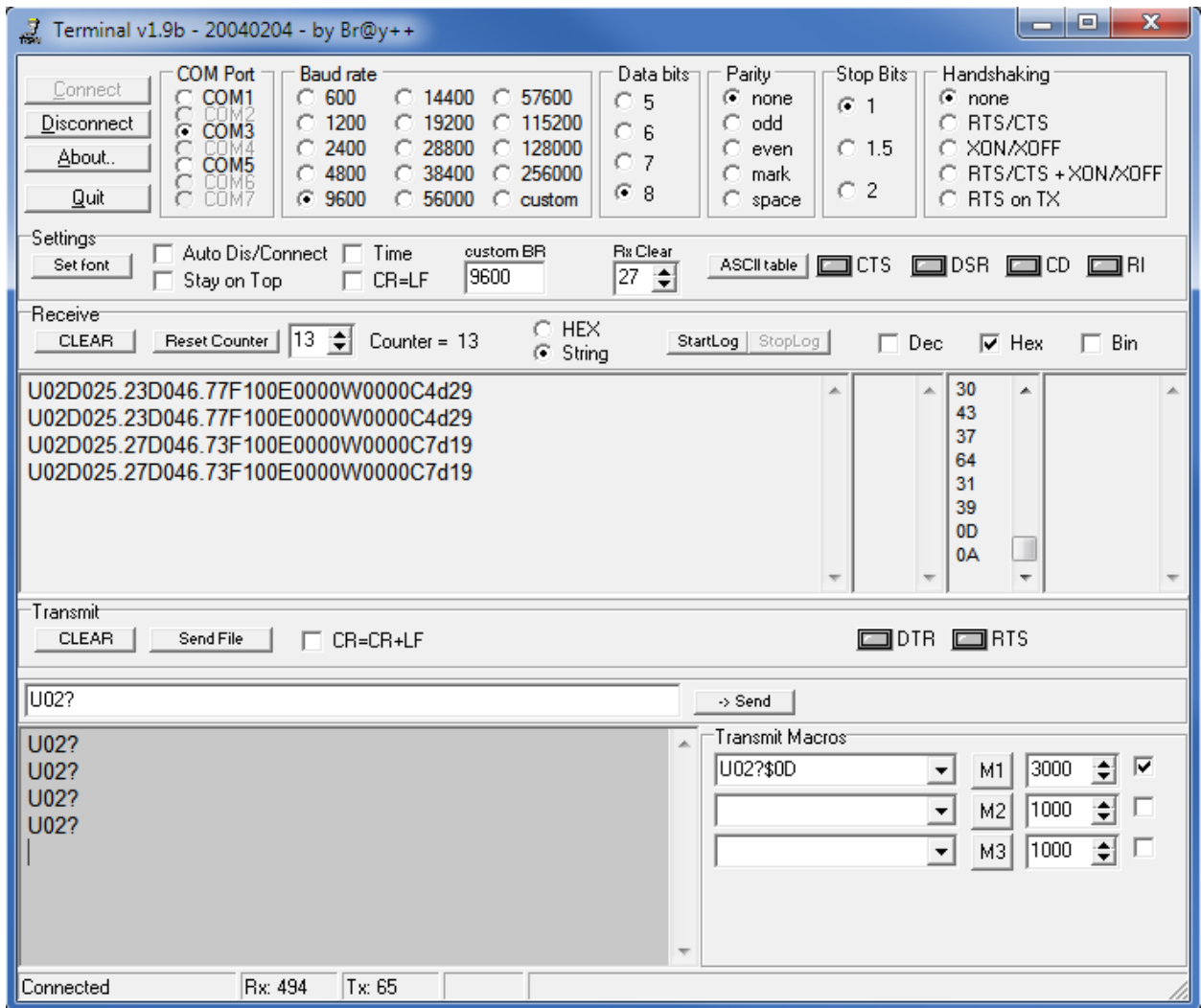

- 12.4.13 Uncheck the checkbox to stop the macro from repeating.
- 12.4.14 Create another Transmit Macro that will send U63?50D and click on the Mx button to the right of the macro definition. This causes the HMA to automatically reboot into the HART over RS-485 mode. There shall be no response from the HMA.
- 12.4.15 Check the checkbox to the right of the U02?50D macro definition.
- 12.4.16 Ensure that there is no response from the HMA.
- 12.4.17 Click on the Disconnect button.
- 12.4.18 Start PACTware.
- 12.4.19 Add a HART Comm DTM to the Project.
- 12.4.20 Left click on the Comm DTM in the Project tree and add a DTM to the Project for one of the listed devices.
- 12.4.21 Right-click on the Comm DTM Project item and select Parameter. Select the correct COM port for the RS-485 communications cable, set the Start address and End address to cover the range of addresses for the attached devices. Set the Comm DTM to be a secondary master, then click OK.



- 12.4.22 Right-click on the Comm DTM Project item and select Additional functions\Change dtm address. Click on the Change address button. Select the address number corresponding to the attached Model 706 device, then click Close.
- 12.4.23 Right-click on the Comm DTM Project item and select Connect.
- 12.4.24 Right-click on the Comm DTM Project item and select Additional functions\Change device address. The DTM will scan for attached devices and display them in a list. If necessary, click on the Refresh button.
- 12.4.25 Ensure that the attached Model 706 is listed and is shown with the correct Poll Address.
- 12.4.26 Right-click on the Comm DTM Project item and select Connect.
- 12.4.27 Double click on the device entry in the Project tree to open the Online parameterization window.
- 12.4.28 Ensure that the DTM communicates with the device and features such as changing parameters and viewing Echo Curves, Echo History (as appropriate) and Trend Data are operational.
- 12.4.29 Close the Online parameterization window.
- 12.4.30 Right-click on the Comm DTM Project item and select Disconnect.
- 12.4.31 Right-click on the Comm DTM Project item and select Parameter. Set both the Start address and End address to 63, then click OK.
- 12.4.32 Right-click on the Comm DTM Project item and select Connect.
- 12.4.33 Right-click on the Comm DTM Project item and select Additional functions\Scan list. The DTM will scan for attached device, sending a HART Command 0 with an address of 63. Receipt of that command by the HMA will cause it to reboot into the Normal operating mode.
- 12.4.34 Shut down PACTware.
- 12.4.35 Open the Terminal application.
- 12.4.36 Click on the Connect button.
- 12.4.37 Create a Transmit Macro that will send Uxx?50D to an attached device and check the checkbox to the right of the macro definition. Note that the xx in the macro represents the Poll Address of the target device.

- 12.4.38 Ensure that the Terminal application is receiving responses from the HMA and that there are no communication errors being reported. The Receive buffer section should have the same number of responses as the Transmit buffer section.

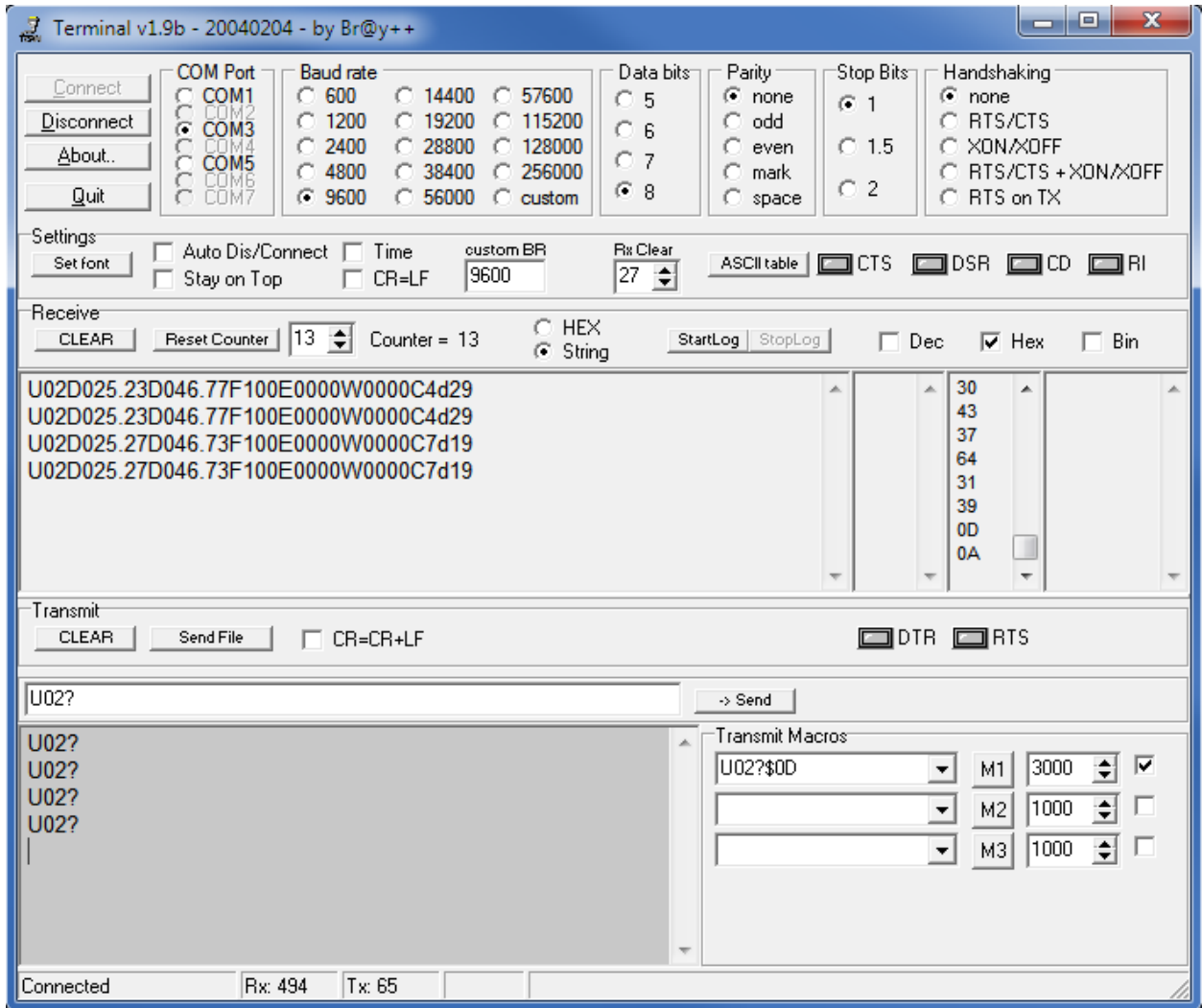

- 12.4.39 If unable to establish communication in the HART over RS-485 mode, the HMA can be reset to normal Modbus operating mode by switching DIP switch 1 to OFF, and cycling power to the unit. The HMA will power up into the default communication mode. Using Procedure 1, set register 1 to 0. The HMA can be used either in that mode, or by setting DIP switch 1 to ON and cycling power, it can be used in its normal Modbus configuration mode.

## 13. HMA Diagnostics

### 13.1. Purpose

This setup procedure instructs how to configure the HART to Modbus Adaptor (HMA) to display diagnostic information. While the default Modbus RTU protocol is used to communicate with the HMA in this procedure, any supported Modbus RTU or ASCII communication configuration can be used.

### 13.2. Equipment

Item	Manufacturer	Model
HART to Modbus Adaptor	MII	031-2859-001
USB Communications cable	FDTIchip	USB-RS485-WE
Termination resistor	-	120Ω
Modbus host application	<a href="http://www.modbustools.com">www.modbustools.com</a>	Modbus Poll
Power Supply	-	20-24V, 0.5A
Level transmitter	MII	Model 706
Probe	MII	Model 706 compatible

### 13.3. Setup

Connect the HMA to a power supply via the power terminal block. Connect an RS-485 communications cable to the RS-485 terminal block of the HMA, with the Receive/Transmit Data+ A lead (orange) on the positive terminal and the Receive/Transmit Data- B lead (yellow) on the negative terminal. Connect a 120Ω resistor between the two RS-485 terminal block positions. Connect the other end of the cable to a PC which has a Modbus host application. Connect up to five Magnetrol HART level transmitters (including the transmitter in the housing containing the HMA) to the HART loop terminal block of the HMA.

### 13.4. Procedure

- 13.4.1 Connect the HMA to a power supply, Modbus host and MII HART transmitters as specified in section 13.3.
- 13.4.2 Using Procedure 1, ensure that registers 3000 through 3007 of the HMA match the values shown for the Modbus RTU protocol default settings. Refer to Appendix F for the HMA Communication settings. If the settings do not match, double-click on a value that needs to be changed in order to open the Write Single Register dialog, enter the new value, and then click on Send.
- 13.4.3 Change register 3012 to a value of 0. This will cause the HMA to scan the attached devices at start-up, and record the poll address and other information for each device.
- 13.4.4 Power cycle the HMA.

13.4.5 To check the slave malfunction diagnostics, open or click on an Mbpoll window, select Setup\Read\Write Definition from the menu bar, ensure that the settings are as follows, and then click OK:

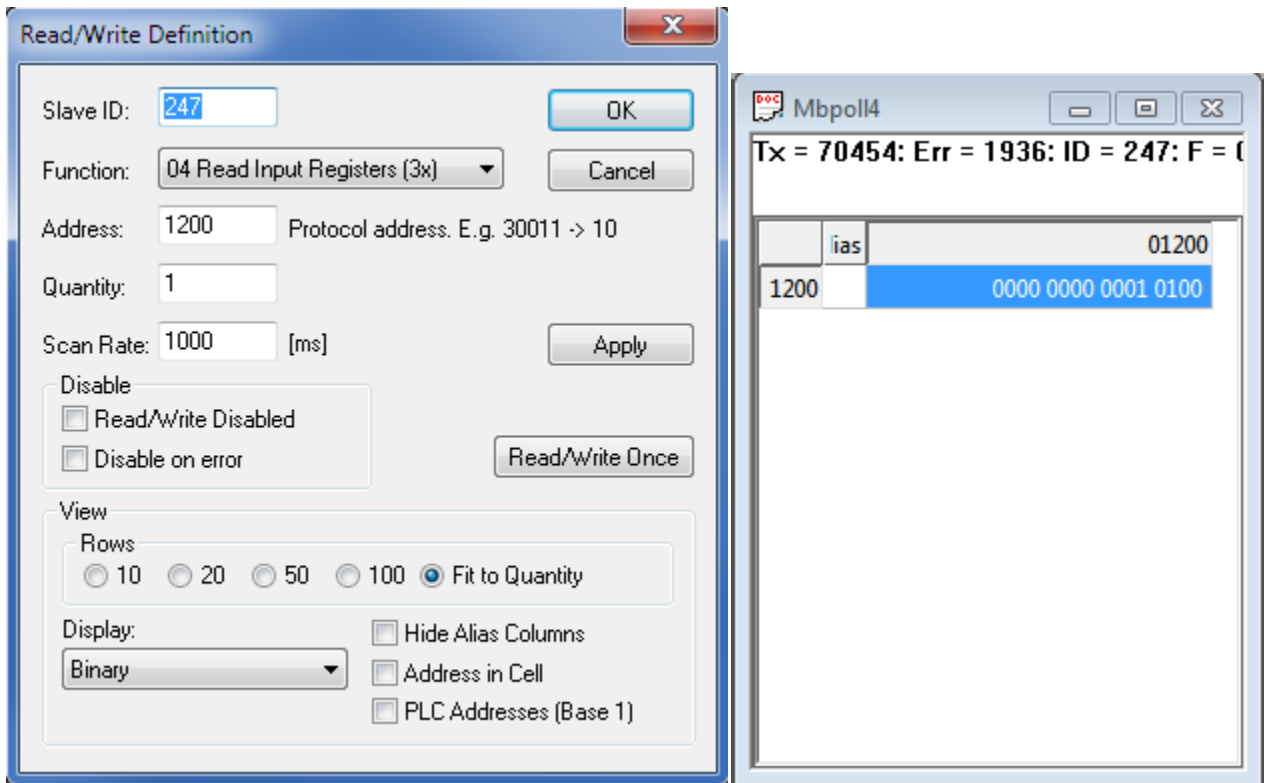

13.4.6 Remove one of the attached HART devices.

13.4.7 Verify that the corresponding slave malfunction bit (see Appendix G) changes to 1.

13.4.8 Reconnect the Model 706 device.

13.4.9 Verify that the corresponding slave malfunction bit changes to 0.

- 13.4.10 To check the types and poll addresses of the attached HART devices, open or click on an Mbpoll window, select Setup\Read\Write Definition from the menu bar, ensure that the settings are as follows, and then click OK:

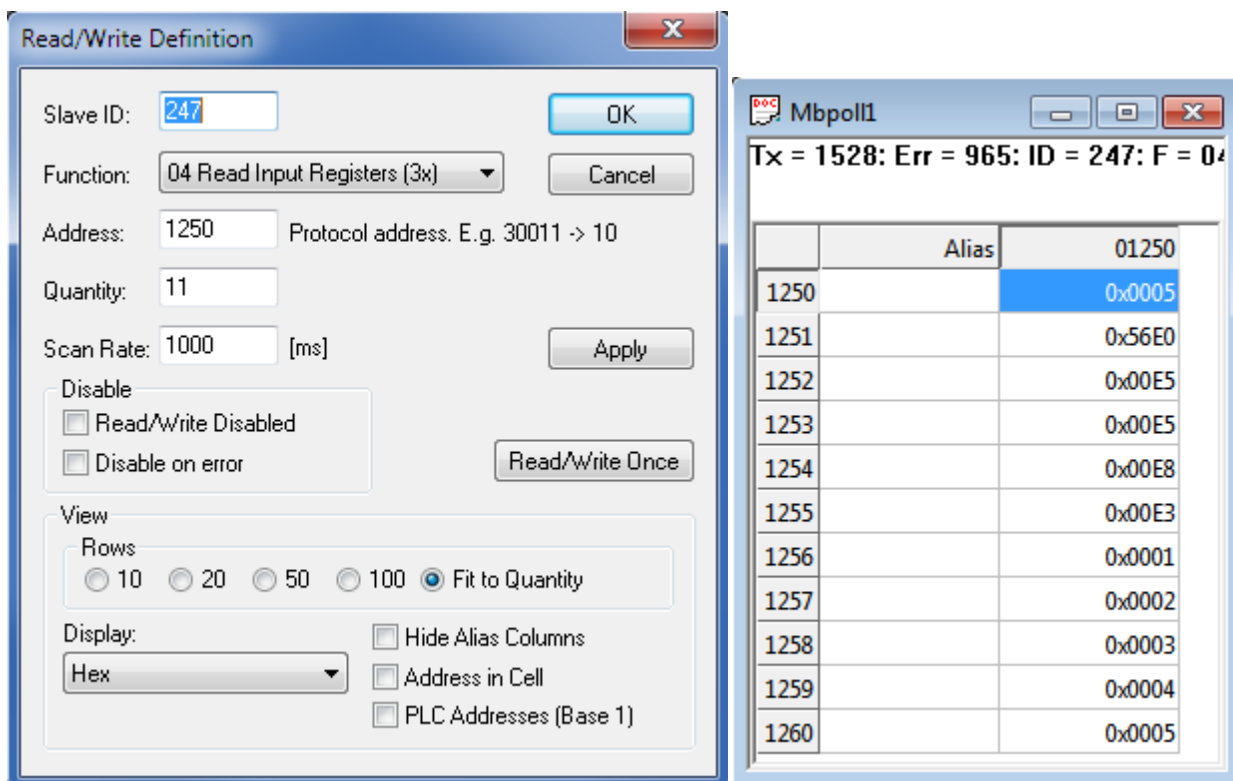

- 13.4.11 Verify that register 1250 indicates the correct number of attached devices.
- 13.4.12 Verify that registers 1256 through 1260 show the correct Poll Addresses of the attached devices.
- 13.4.13 Verify that registers 1251 through 1255 show the correct Device Types of the attached devices for each corresponding Poll Address.

13.4.14 To check the device information for the attached HART devices, open or click on an Mbpoll window, select Setup\Read\Write Definition from the menu bar, ensure that the settings are as follows, and then click OK:

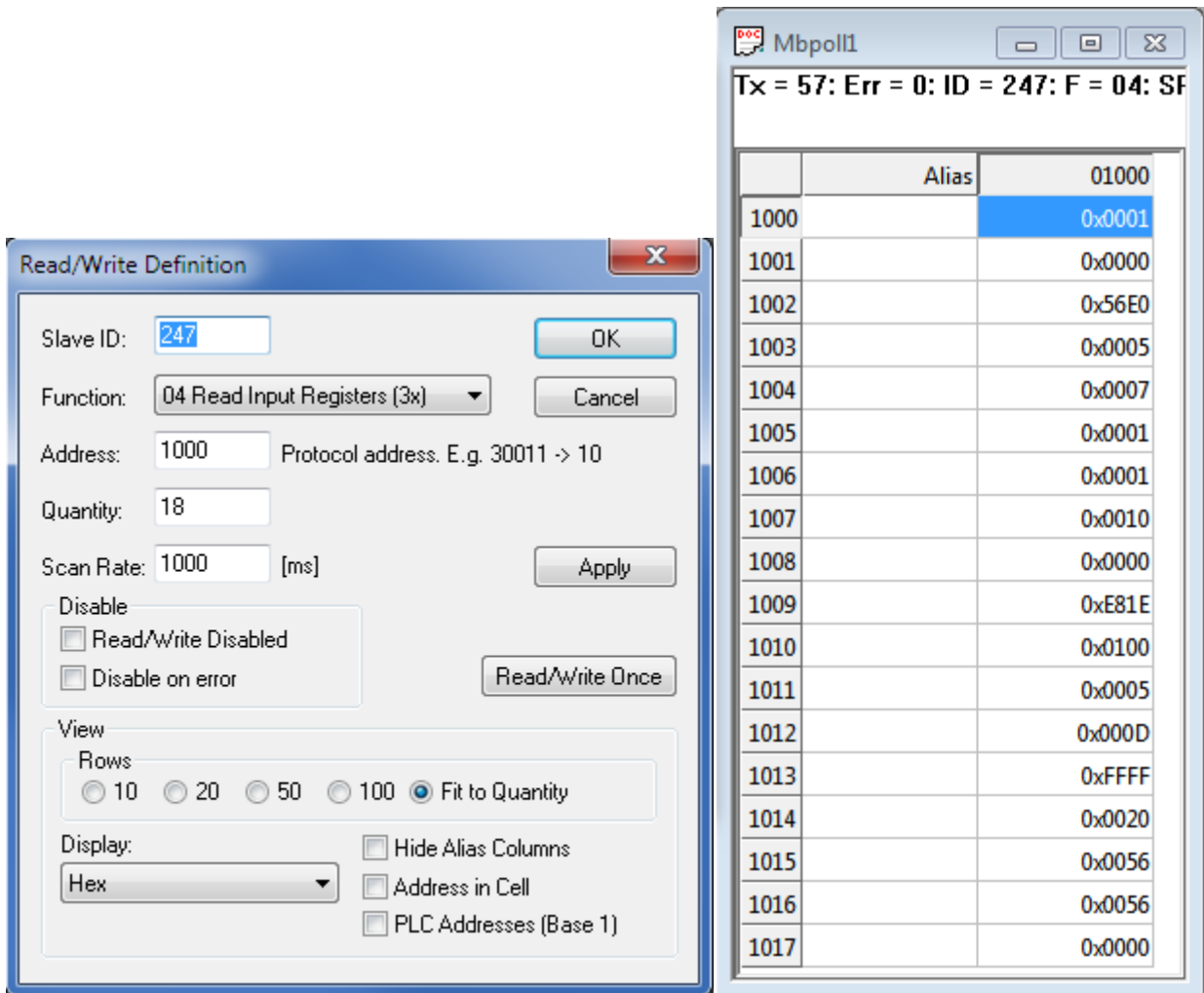

13.4.15 Verify that registers 1000 through 1017 show the correct information for the attached device as listed in Appendix H.

13.4.16 Repeat steps 13.4.14 and 13.4.15 for the remaining four devices, changing the register addresses as appropriate.

## 14. ROCLINK 800

### 14.1. Initial HMA Configuration

- 14.1.1 Using Procedure 1, ensure that registers 3000 through 3007 of the HMA match the values desired for communication with the ROC 800. Refer to Appendix F for the HMA Communication settings. If the settings do not match, double-click on a value that needs to be changed in order to open the Write Single Register dialog, enter the new value, and then click on Send.

### 14.2. Physical Connections

- 14.2.1 Connect the ROC 800 to a computer using an LOI RS-232 cable.
- 14.2.2 Connect an appropriate power supply to the power supply module of the ROC 800.
- 14.2.3 Connect the HMA to a 9 – 30 VDC power supply via terminal block TB1.
- 14.2.4 Connect an RS-485 communications cable between terminals A and B of the ROC 800 RS-485 module and the RS-485 terminal block (TB2) of the HMA.
- 14.2.5 Connect a 120Ω resistor between the two RS-485 terminal block positions of the last HMA on the bus

### 14.3. Initial ROC 800 Configuration

- 14.3.1 Start the ROCLINK 800 application.
- 14.3.2 Select ROC \ Direct Connect in the ROCLINK 800 Menu bar. An image of the front of the ROC 800 will appear.
- 14.3.3 Mouse over the image of the RS-485 module. A flyover text box will appear that identified the Comm Port used for RS-485 communication with the HMA.



14.3.4 Click on ROC \ Comm Ports in the ROCLINK 800 Menu bar.

14.3.5 Ensure that the communication settings for 1 – Local Port are as follows.

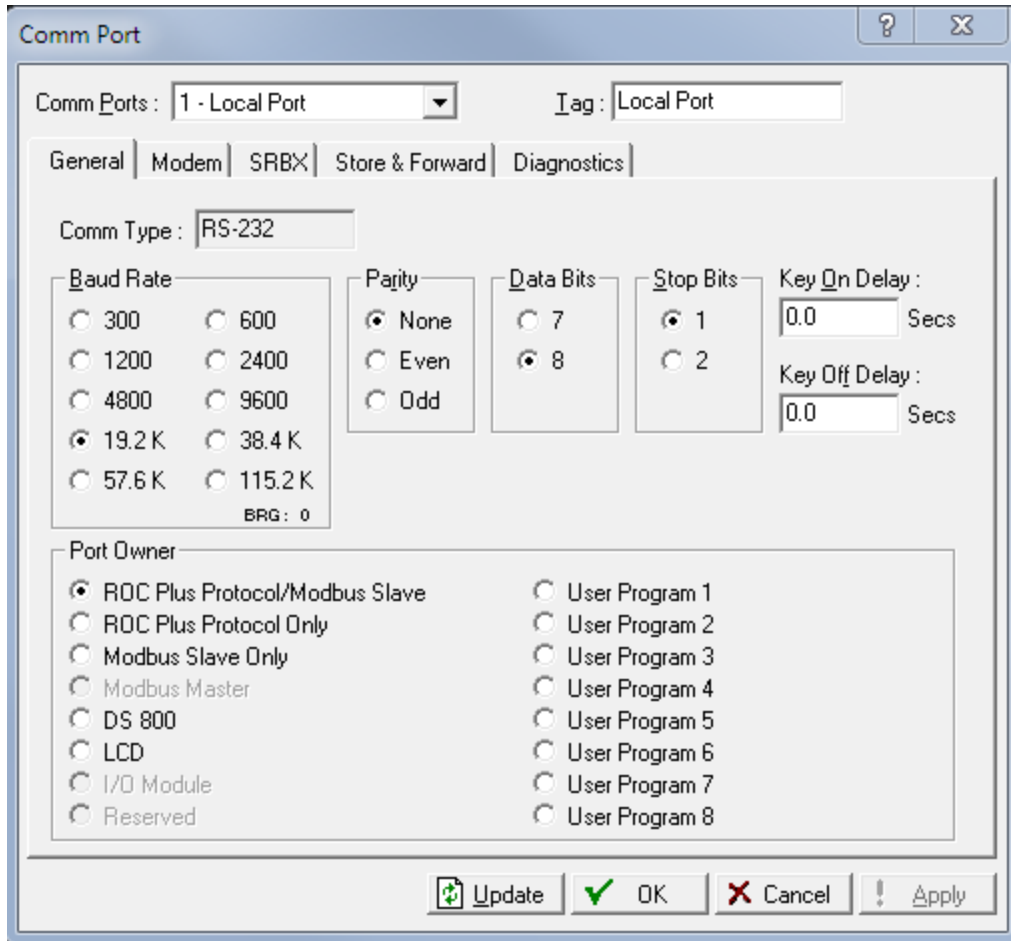



- 14.3.6 For Comm Ports, select the port number displayed in step 14.3.3.
- 14.3.7 Ensure that the communications settings match the settings of the HMA performed in step 1.1.8, then click OK. Ensure that the Port Owner is set to Modbus Master. For example,

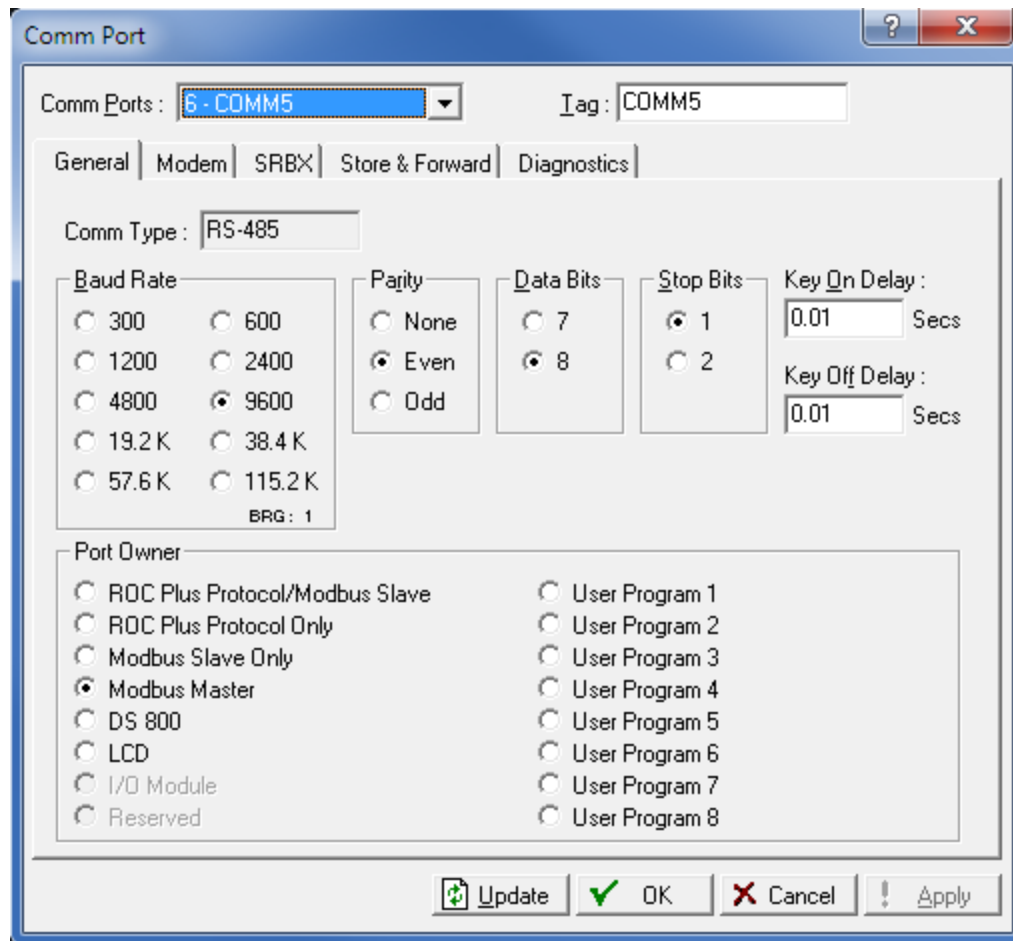

#### 14.4. Reading registers from the HMA

- 14.4.1 Select Configure \ MODBUS from the ROCLINK 800 Menu bar.
- 14.4.2 Change the Comm Port to match the port to which the HMA is connected.
- 14.4.3 The followings steps demonstrate how to read the PV, SV, TV and QV as well as the Blocking Distance from a HART device attached to the HMA.

- 14.4.4 For the General tab,
- 14.4.5 Ensure that the Byte Order and Comm Mode match the selections made in step 14.1.1.
- 14.4.6 Check 'Start Polling'. Set the Starting Request to 1 and the Number of Requests to match the total number of separate rows defined in the Master Table tab below.
- 14.4.7 Select the Enabled radio button in the Continuous Polling group box.

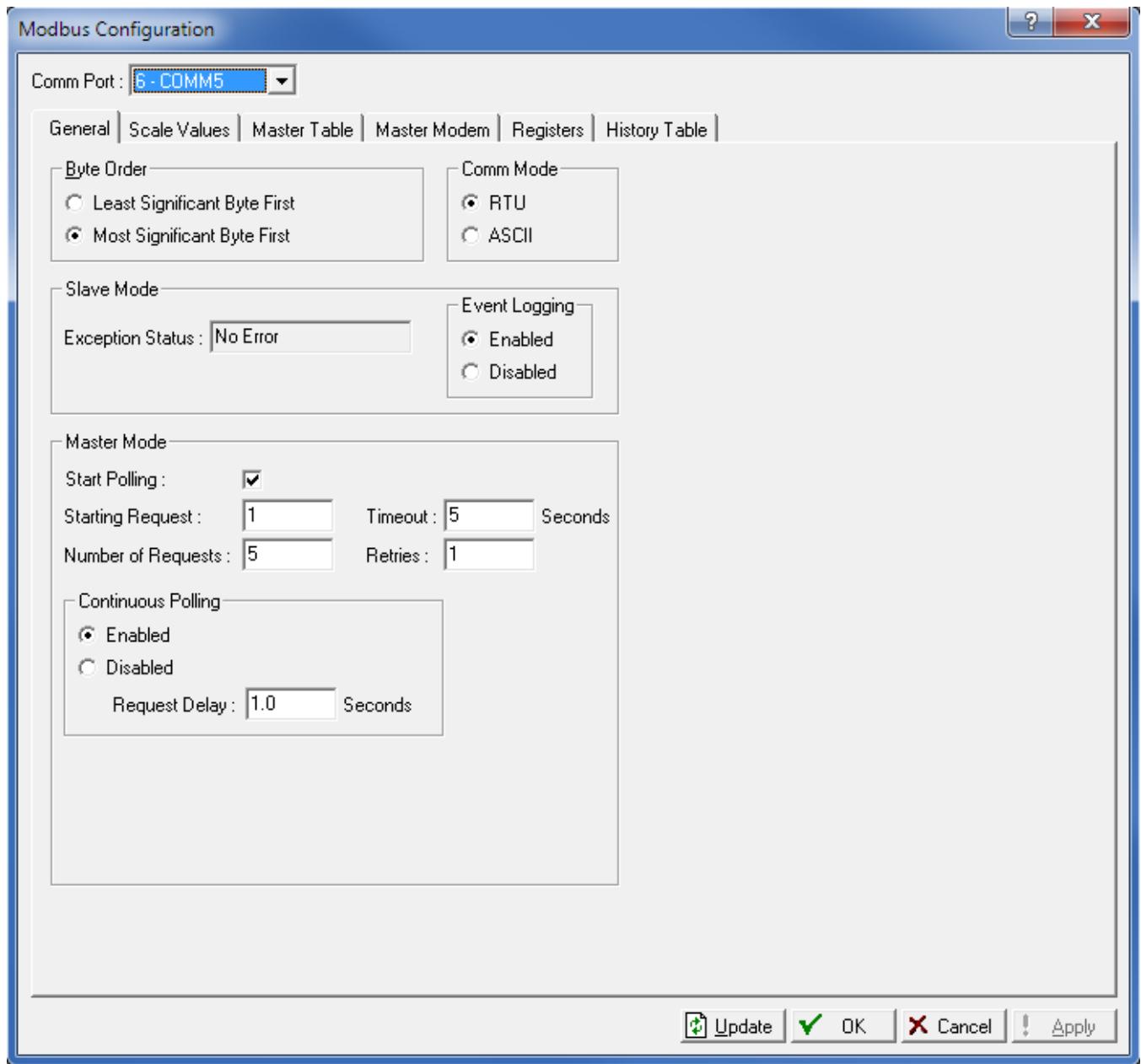

14.4.8 For the Master Table tab,

14.4.9 Set the Logical Point to 13 – MastTbl 13 (COMM5).

14.4.10 Enter into the table the sets of registers to be read from the device. Set the RTU Address to that of the HMA when it is in the HMA mode. Set the RTU Address to that of the individual attached HART device to be queried when the HMA is in the 'Device' mode.

14.4.11 In the example below, the HMA is in 'HMA' mode and has an address of 247.

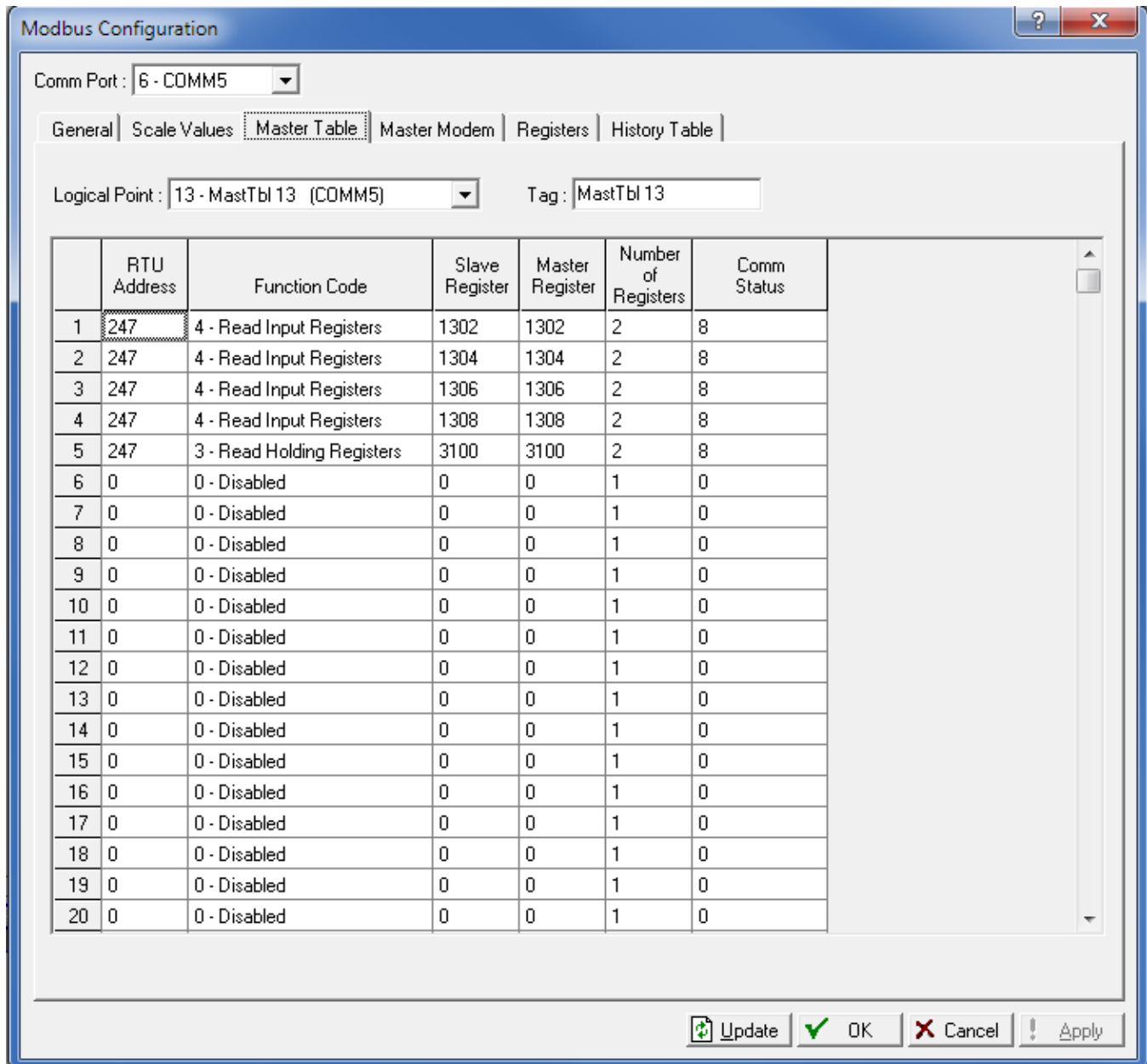

14.4.12 For the Registers tab,

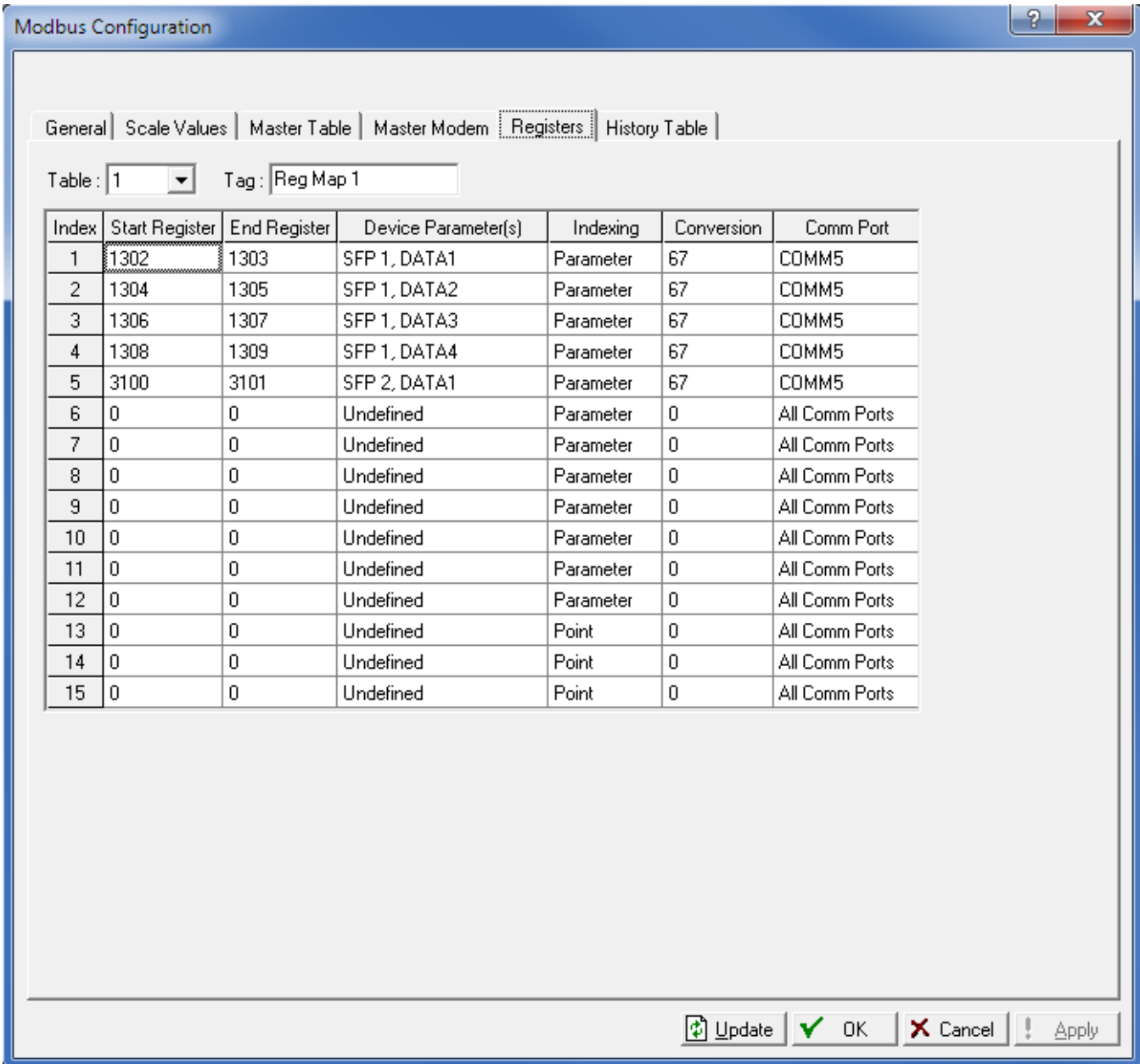

14.4.13 Set the Table to 1, and for each variable to be read,

14.4.14 Enter the Start and End Register numbers. Refer to Appendices F through O for register numbers of the HMA and attached HART devices.

14.4.15 Create a Soft Point and Data number in the Device Parameter(s) column. Click on the ellipsis button that appears at the right side of the cell to open the 'Select TLP' dialog.

Index	Device Parameter(s)	
1	SFP 1, DATA1	F
2	SFP 1, DATA2	F
3	SFP 1, DATA3	F

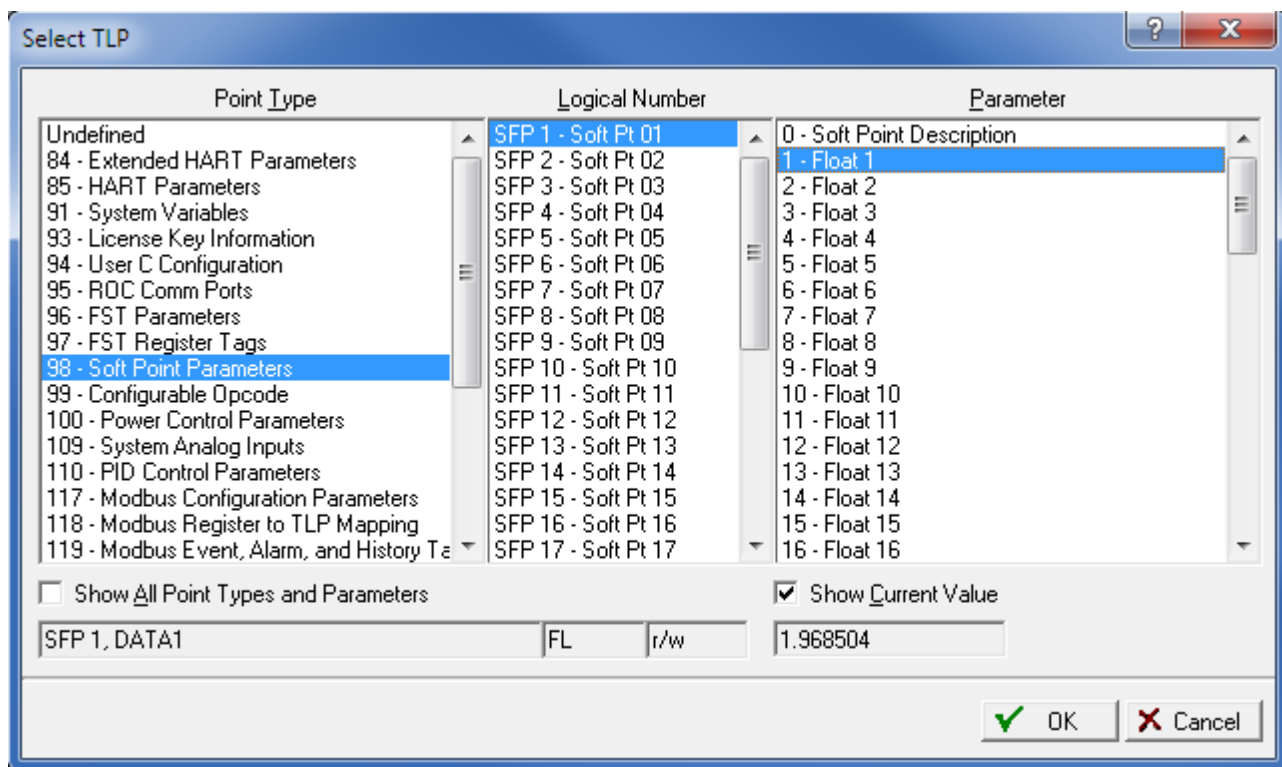

- 14.4.16 Select 98 – Soft Point Parameters for the Point Type, SFP 1 – Soft Point 01 for the Logical Number, and 1 – Float 1 for the Parameter. Note the name for the point, for example, SPF 1, DATA 1. By checking ‘Show Current Value’, one can confirm that the desired parameter is being read correctly. Then click ‘OK’ to close the Select TLP dialog.<sup>3</sup>
- 14.4.17 Set a Convert Code (see ROCLINK 800 Help) in the Conversion column ( ) to properly interpret the data bytes into the correct numerical format.
- 14.4.18 Assign the correct Comm Port number.
- 14.4.19 Repeat as required for the remaining parameters to be read from the device.
- 14.4.20 Return to Master Table tab and ensure that the Comm Status for each line is 8, indicating a Valid Slave Response.

<sup>3</sup> Select ‘Short’ for the Parameter type when setting up to read the unsigned integer communication registers 3000 through 3007 in the HMA.

14.4.21 To display the values,

14.4.22 Open the Soft Point dialog by selecting I/O \ Soft Point in the Configuration Tree window, then double-clicking on #1, Soft Pt 01.

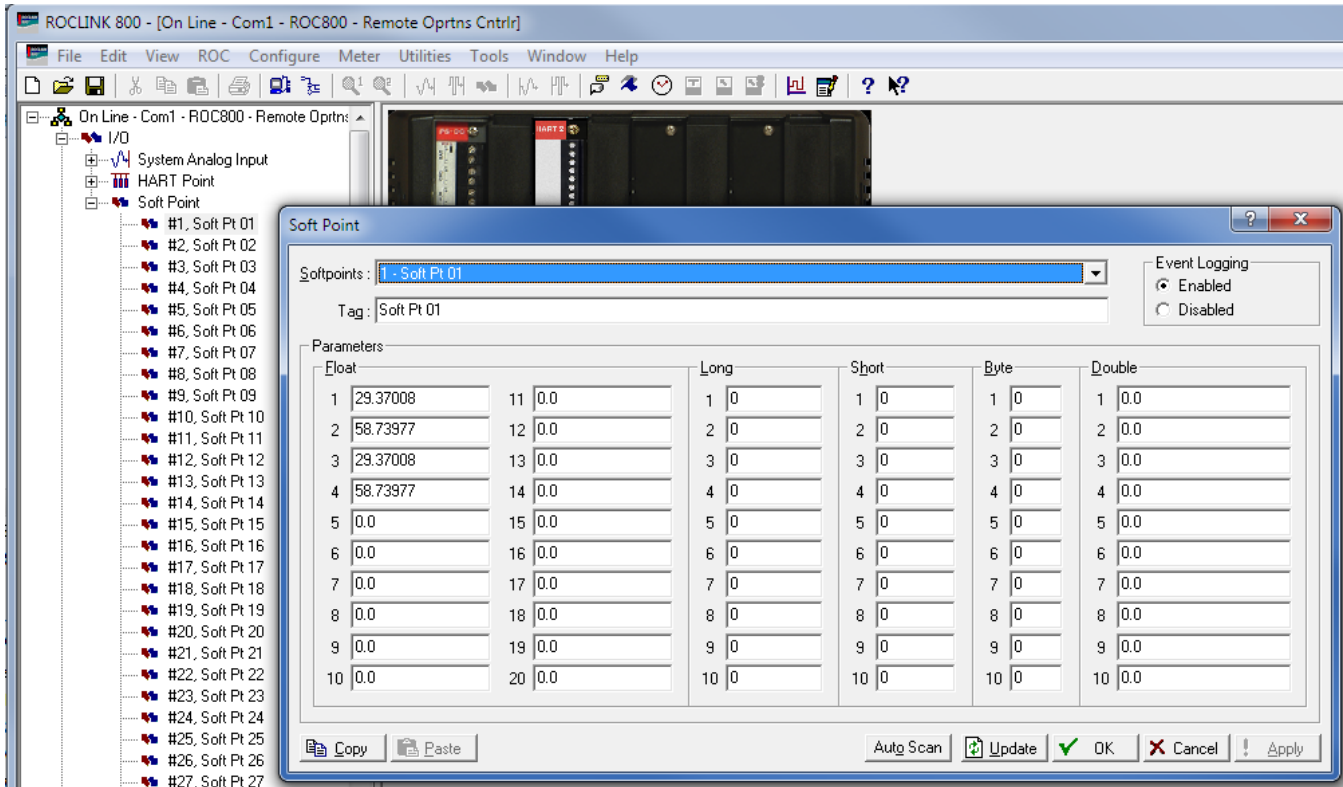

14.4.23 Click on Update to read a single set of values from the device, or Auto Scan to repeatedly update the displayed values.

## 14.5. Writing registers to the HMA

- 14.5.1 Configure the ROC 800 to access a register in the HMA or attached HART device as for reading a register from the HMA (section 14.4).
- 14.5.2 When setting up the row in the Configure \ MODBUS \ Master Table tab, use Function code 16 – Preset Multiple Registers for multi-byte parameters, or 6 – Preset Single Register for single-byte parameters.
- 14.5.3 Click Update to send the new setting to the ROC 800.
- 14.5.4 Open the Soft Point dialog by selecting I/O \ Soft Point in the Configuration Tree window, then double-clicking on #1, Soft Pt 01.
- 14.5.5 Highlight the value to be changed and enter the new value.
- 14.5.6 Click on Update to send the new value to the device.
- 14.5.7 Return to the Configure \ MODBUS \ Master Table tab.
- 14.5.8 Change the Function Code for the parameter to 3 – Read Holding Registers or 4 – Read Input Registers as appropriate.
- 14.5.9 Click on Update to send the new setting to the device.
- 14.5.10 Return to the Soft Point dialog by selecting I/O \ Soft Point in the Configuration Tree window, then double-clicking on #1, Soft Pt 01.
- 14.5.11 Click on Update to confirm that the device has accepted the new value.

## **15. ABB Totalflow XRC – Modbus RTU / ASCII**

The following procedure applies to operation with both RTU and ASCII communication. The choice of communication protocol is made in step 15.1.1 for the HMA settings and in step 15.3.10 for the Totalflow XRC. The Modbus RTU protocol is used for the following.

### **15.1. Initial HMA Configuration**

- 15.1.1 Using Procedure 1, ensure that registers 3000 through 3007 of the HMA match the values desired for Modbus communication with the ABB TotalFlow XRC. Refer to Appendix F for the HMA Communication settings. If the settings do not match, double-click on a value that needs to be changed in order to open the Write Single Register dialog, enter the new value, and then click on Send.

### **15.2. Physical Connections**

- 15.2.1 Connect the ABB Totalflow XRC to a computer using a USB-A to USB-B cable.
- 15.2.2 Connect an appropriate power supply to the battery charging terminal (J17) of the ROC 800.
- 15.2.3 Connect the HMA to a 9 – 30 VDC power supply via terminal block TB1.
- 15.2.4 Connect an RS-485 communications cable between the RS-485 module of the ROC 800 and the RS-485 terminal block (TB2) of the HMA.
- 15.2.5 Connect a 120 $\Omega$  resistor between the two RS-485 terminal block positions of the last HMA on the bus

### **15.3. Initial XRC Configuration**

- 15.3.1 Start the PCCU32 application.
- 15.3.2 Select on Operate \ Setup \ System Setup in the PCCU32 Menu bar. A dialog will appear allowing for communication settings between the PCCU32 application and the XRC.



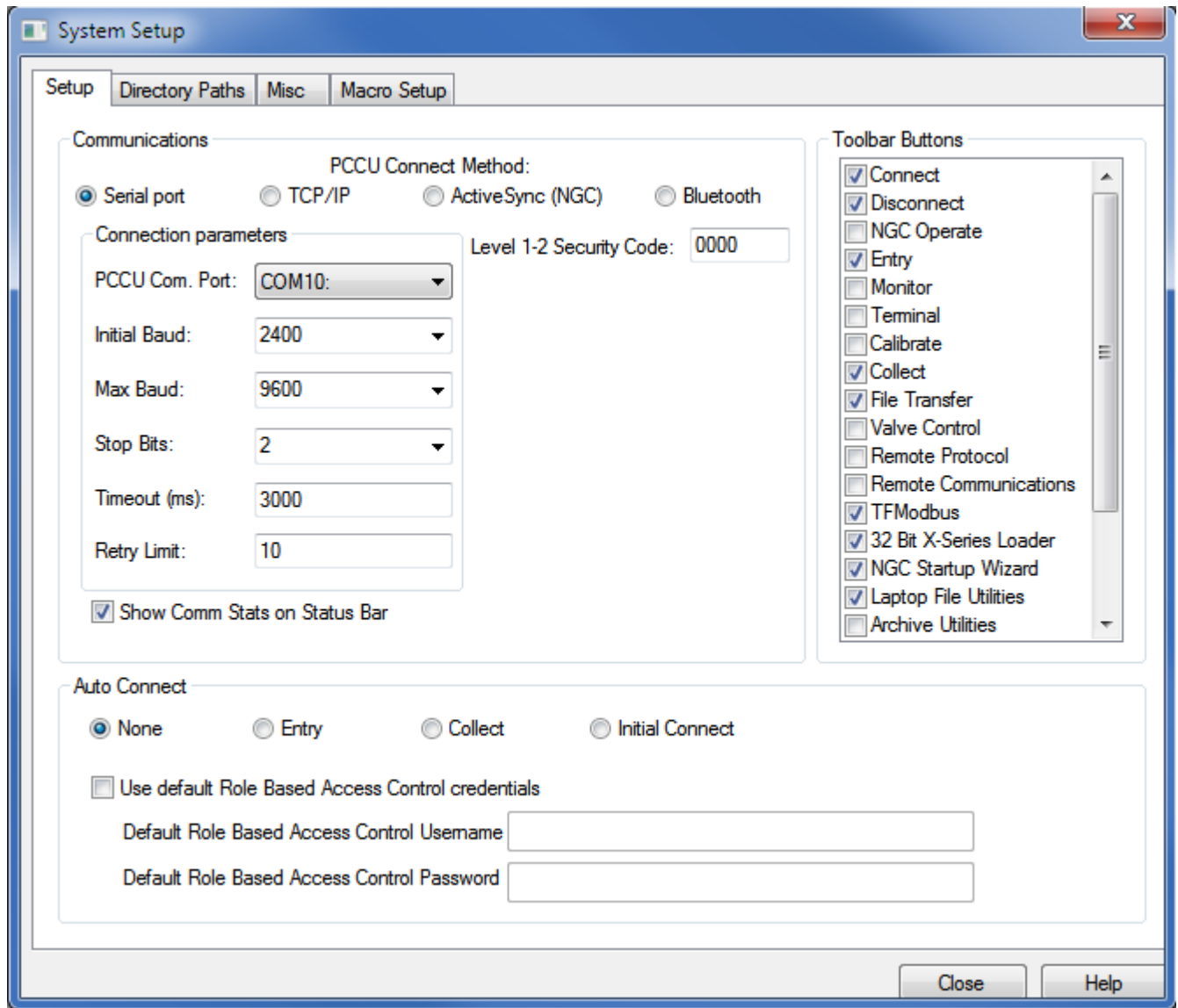

15.3.3 Select the COM port number corresponding to the XRC.

15.3.4 Click Close.

15.3.5 Select on Operate \ Connect to Totalflow in the PCCU32 Menu bar.

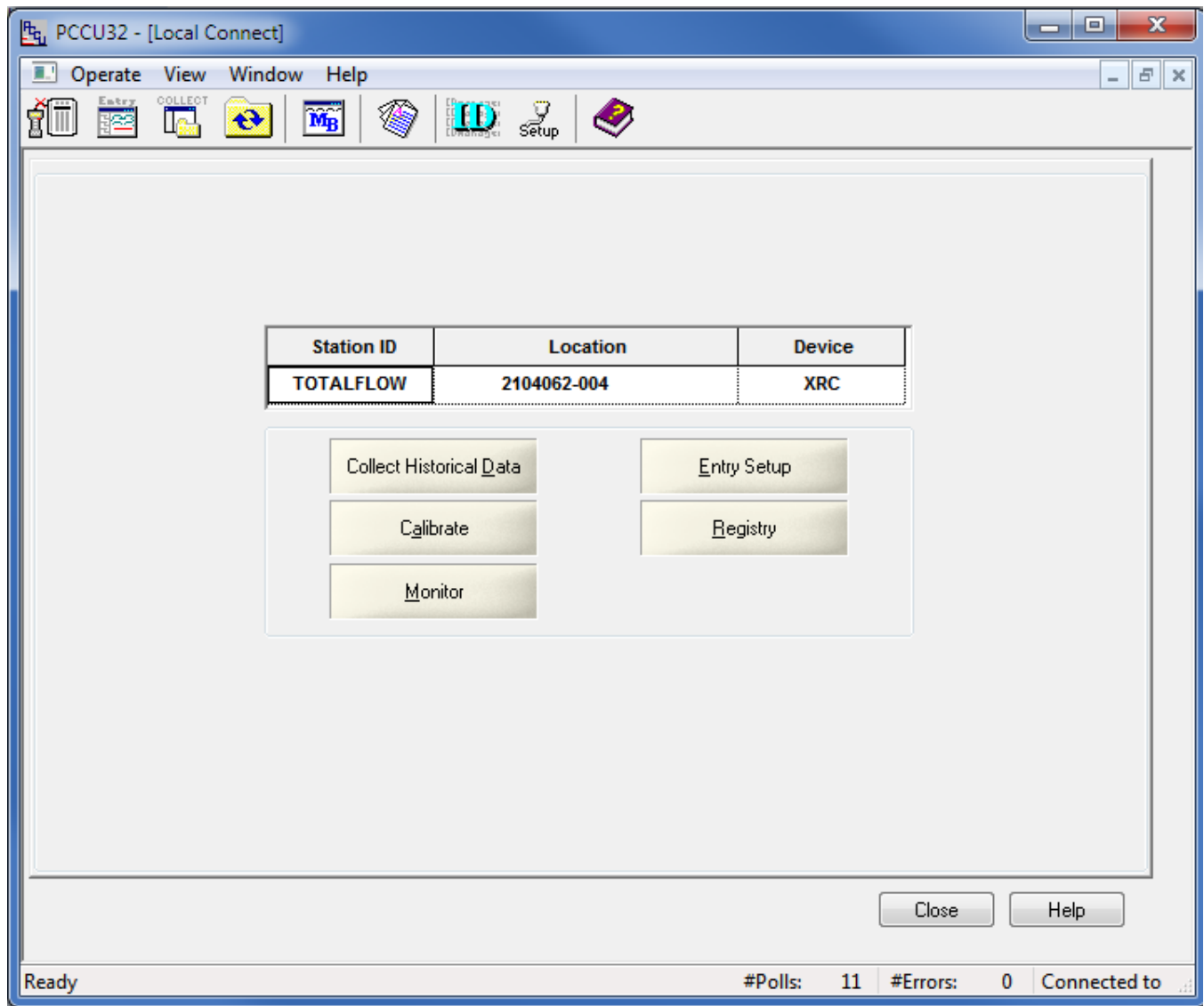

15.3.6 Select Entry Setup from the Local Connect initial dialog.

15.3.7 Select View \ Advanced from the PCCU32 menu bar.

- 15.3.8 Click on Communications in the tree-view window.
- 15.3.9 Click on the Port name associated with Modbus RTU.
- 15.3.10 Ensure that the communications settings match the settings of the HMA performed in step 15.1.1, then click OK. For example,

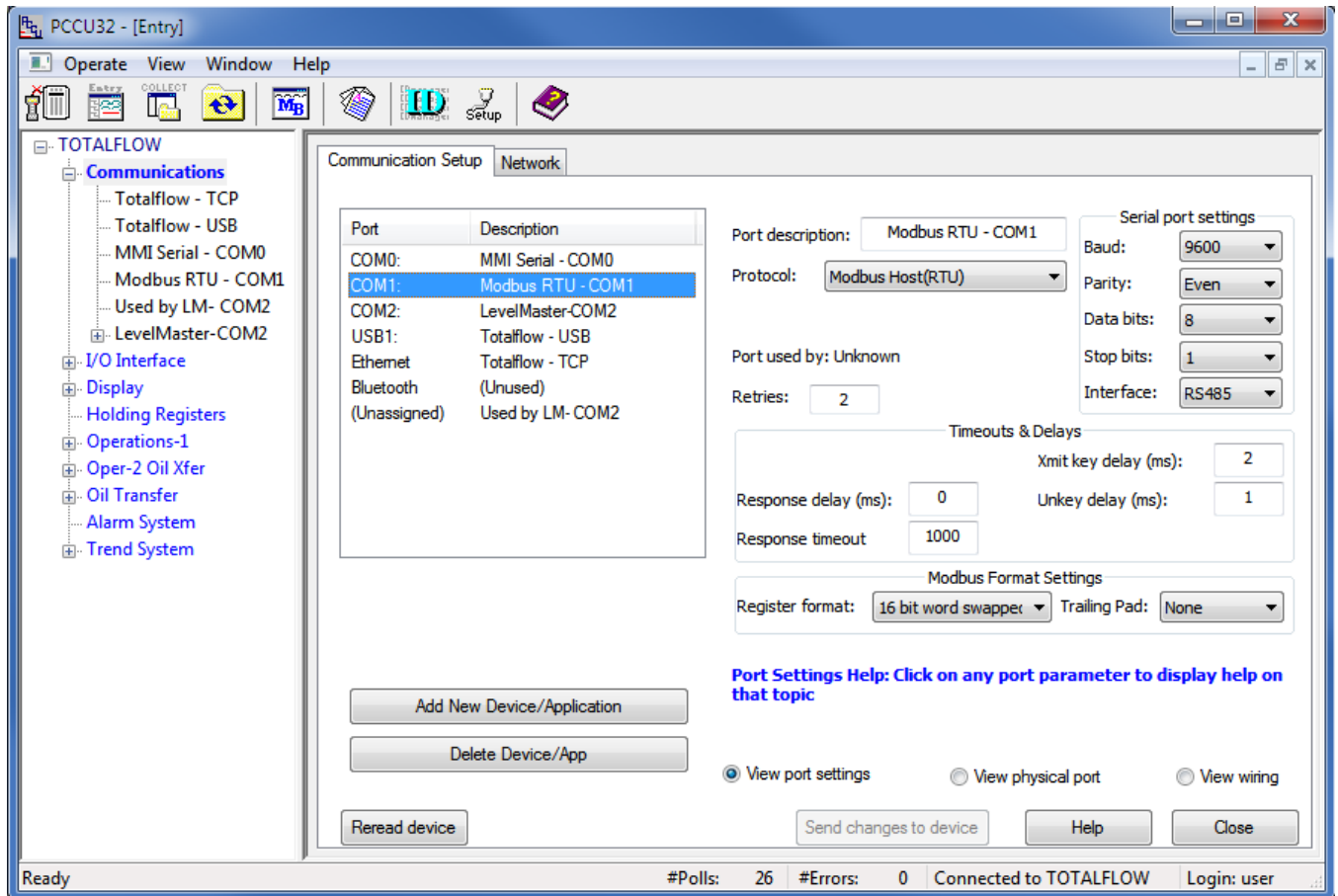

15.3.11 The terminal block connections on the XRC can be verified by clicking on the View Wiring radio button.

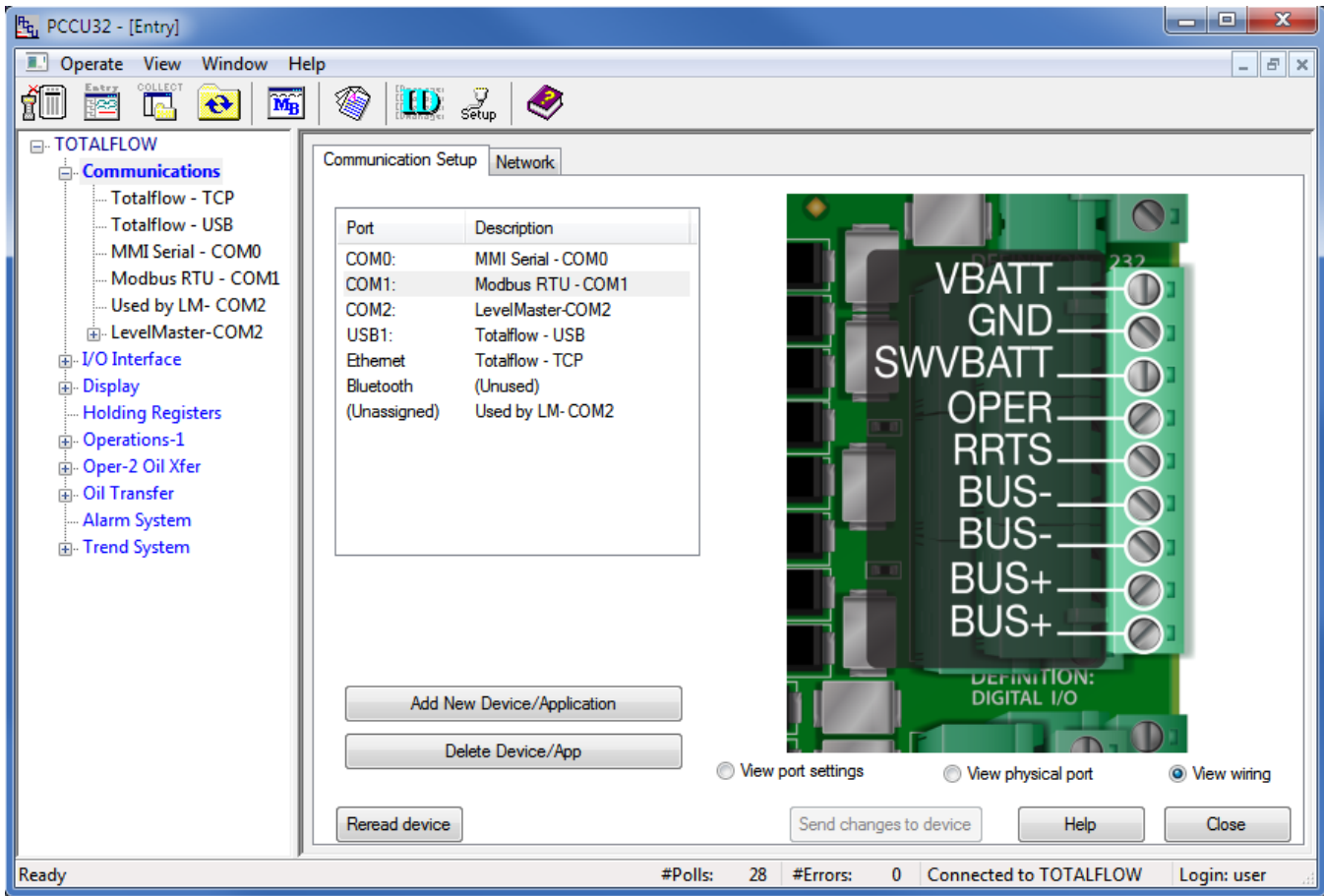

## 15.4. Reading registers from the HMA

- 15.4.1 The followings steps demonstrate how to read the PV, SV, TV and QV from a HART device attached to the HMA. When making any changes to the settings, click on Send at the bottom of the window to write them to the XRC.
- 15.4.2 Select Holding Registers from the tree-view window of the PCCU32.
- 15.4.3 Select the Capacity tab.
- 15.4.4 Set the Capacity for the Number of Arrays to 1.
- 15.4.5 Set the Capacity for Array 1 to '4', the Type to 'Float', the 'Persistence' to 'Non-Persistent', and the Name to 'Dynamic Variables'.

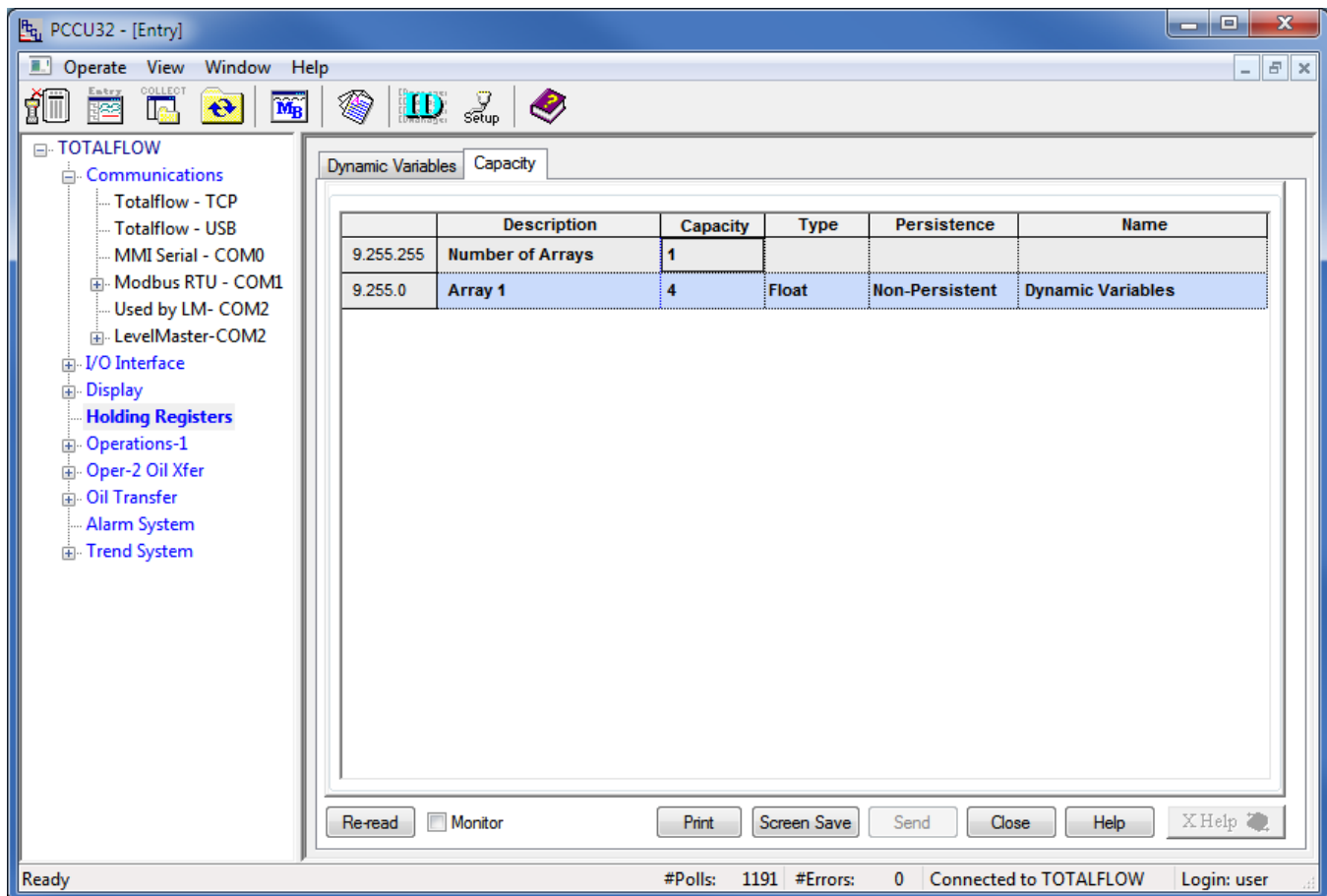

15.4.6 Select the Dynamic Variables tab.

15.4.7 Change the description of the four registers to 'PV' through 'QV'.

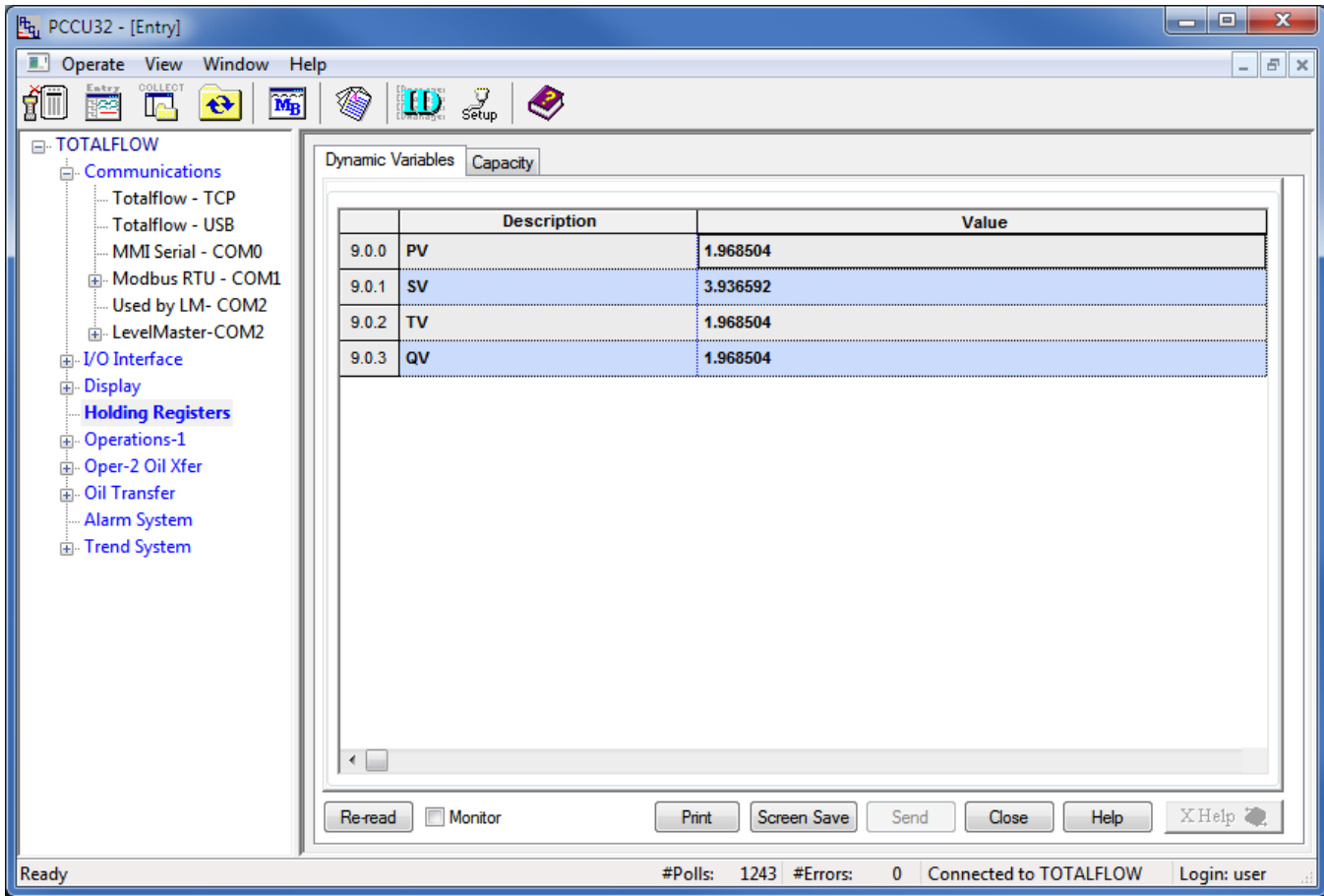

15.4.8 Note the Register numbers displayed in the first column of the table. They will be used when setting the Request Blocks in a later step.

15.4.9 Select Communications \ Modbus RTU in the tree-view window.

15.4.10 For the Setup tab,

15.4.11 Ensure that the Protocol and Baud Rate match the selections made in step 15.1.1.

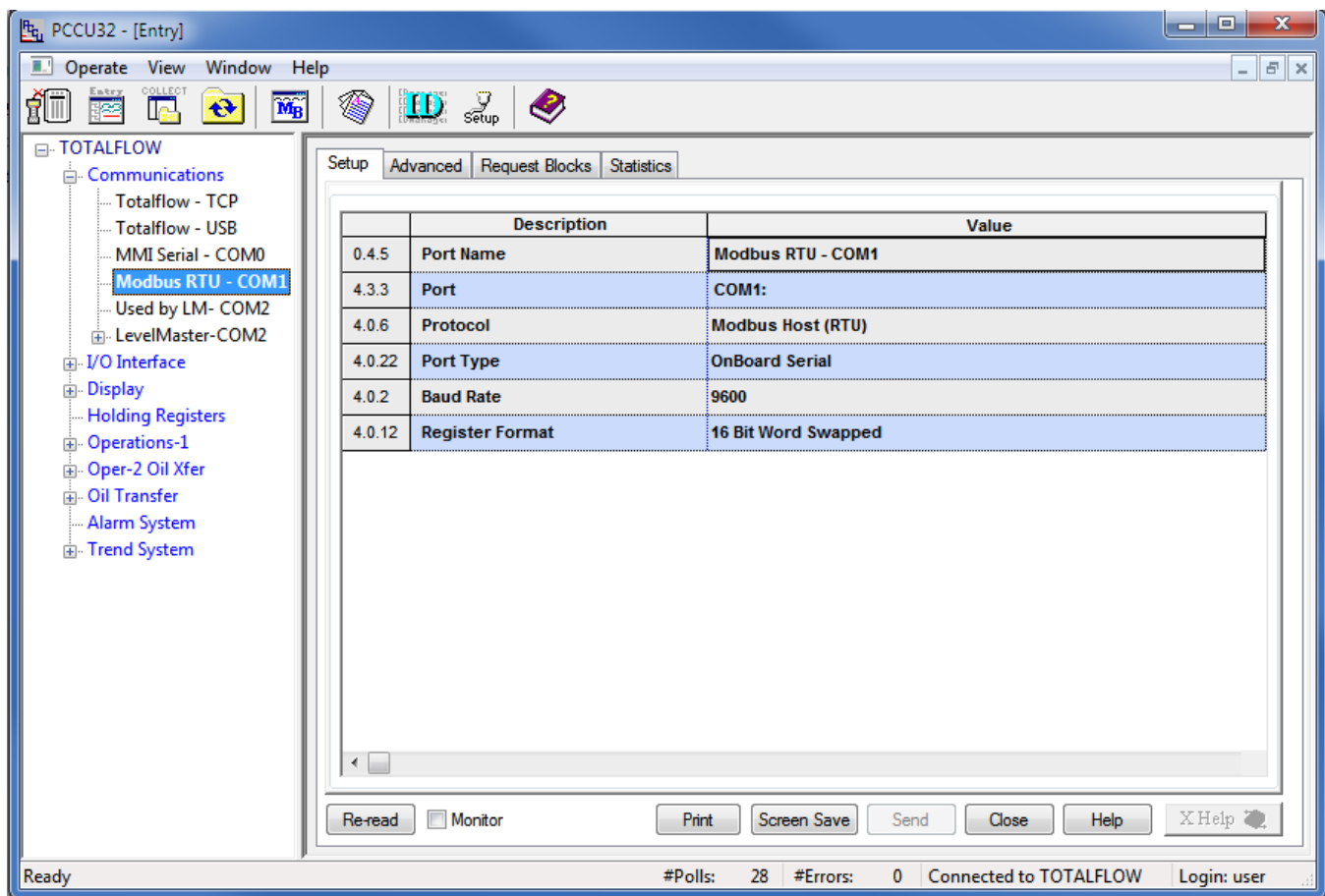

15.4.12 For the Advanced tab,

15.4.13 Ensure that the Data Bits, Parity and Stop Bits match the selections made in step 15.1.1.

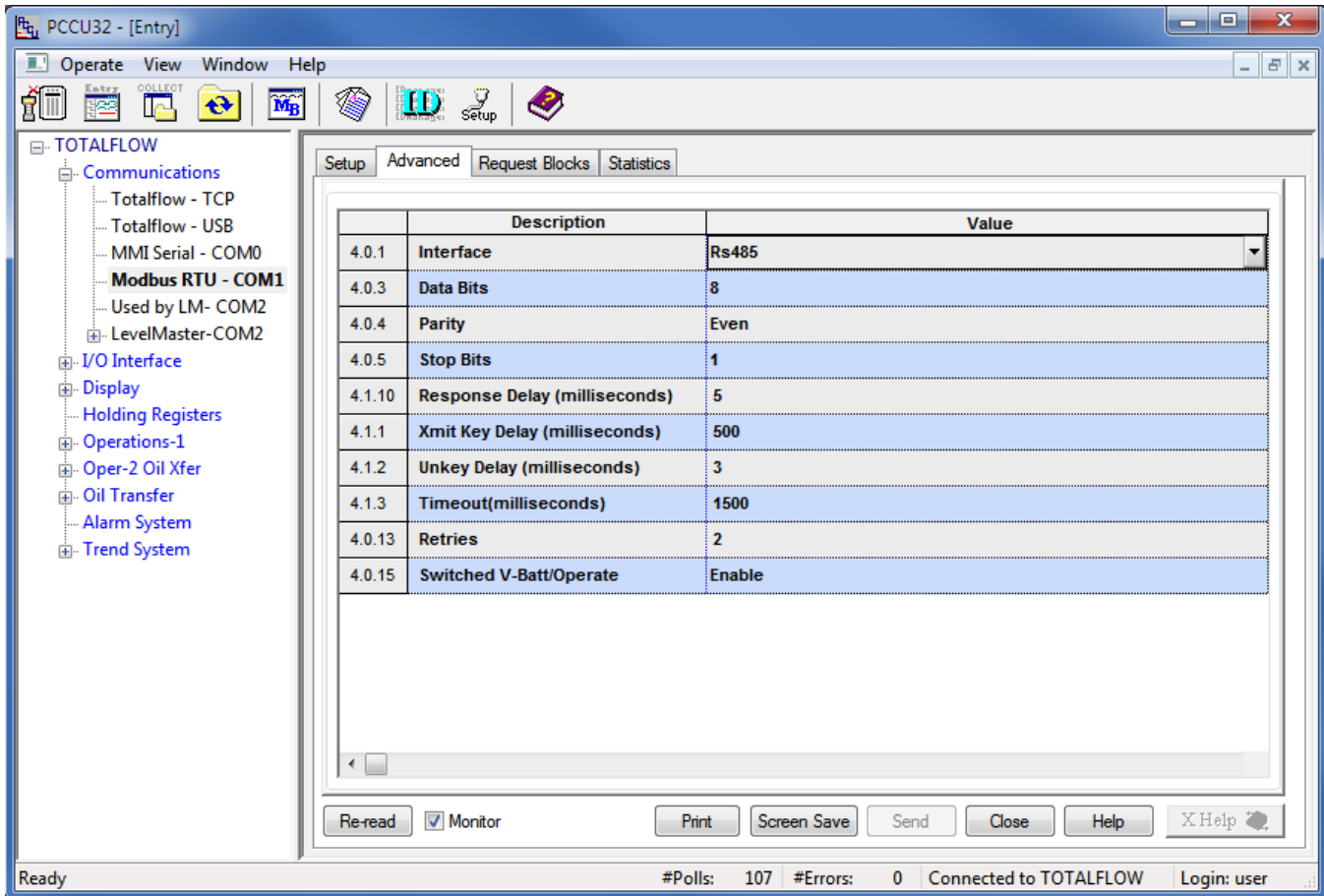

15.4.14 Ensure that the Unkey Delay is less than 7 milliseconds as the HMA typically responds within about 8 milliseconds. If the Unkey Delay time is too long, the XRC will start listening for a response after the HMA has already started transmitting. As a result, the XRC will not recognize the response.



- 15.4.15 For the Request Blocks tab,
- 15.4.16 Set the Slave Address to match the address of the HMA (if in HMA mode), or an attached device (if in Device mode).
- 15.4.17 Select '4 – Read Input Registers' from the Modbus function drop-down.
- 15.4.18 Set the Starting Register to a value 1 greater than the desired starting Modbus register. Refer to Appendices F through O for register numbers of the HMA and attached HART devices.

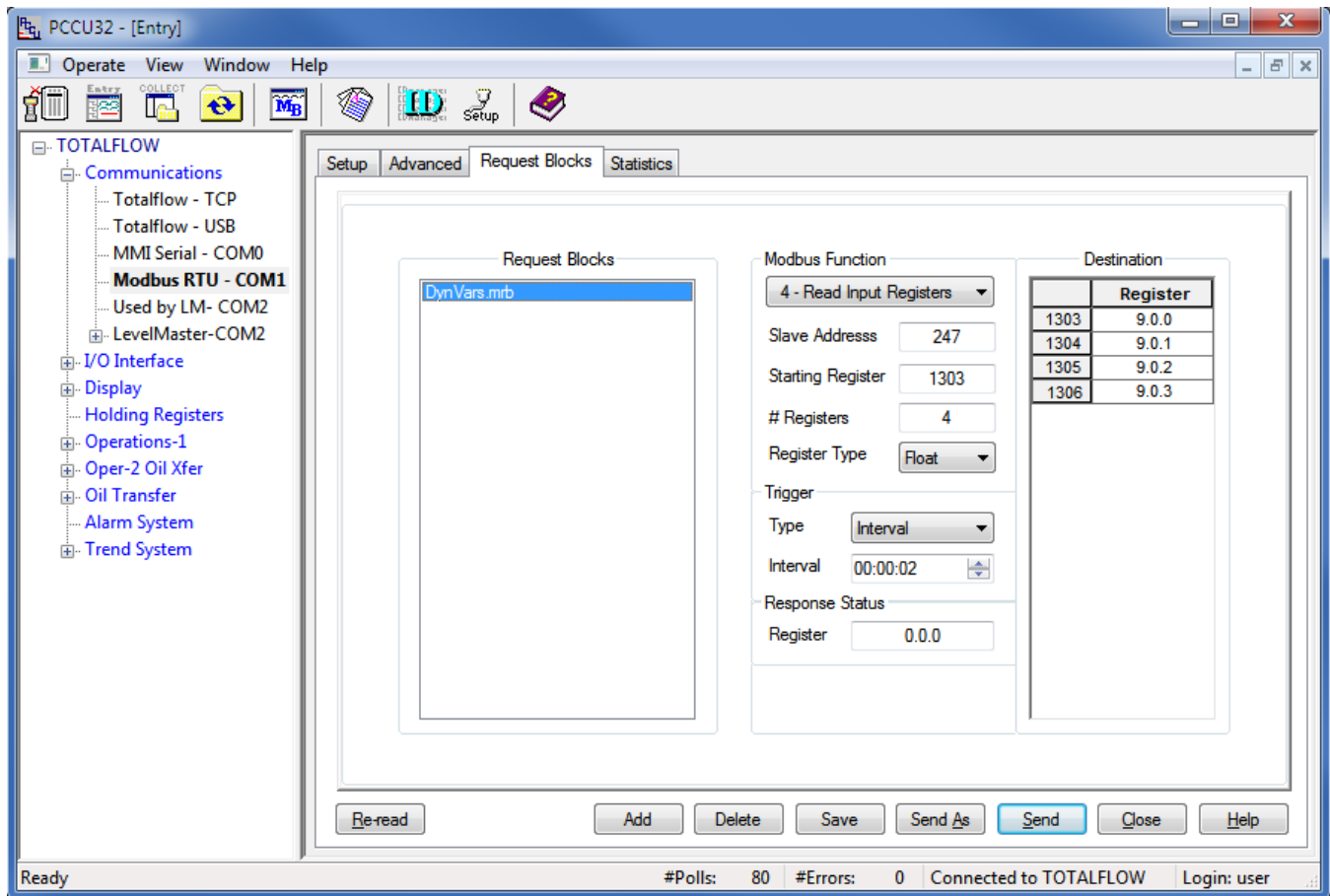

- 15.4.19 Set the # Registers to equal the total number of Dynamic Variables to be read. Note that in this case, 4 Dynamic Variables are to be read so that a value of 4 is entered even though the total number of 16-bit Modbus registers that will be read is 8.
- 15.4.20 Set the Register Type to Float.
- 15.4.21 Set the Trigger Type to Interval and the Interval time to the desired sampling rate.
- 15.4.22 Set the Destination Registers to the register numbers from step 15.4.8.

15.4.23 To check if transmissions and responses are being made, select View \ Expert from the PCCU32 Menu bar. This mode displays a Packet Log tab when selecting Communications \ Modbus RTU from the tree-view window.

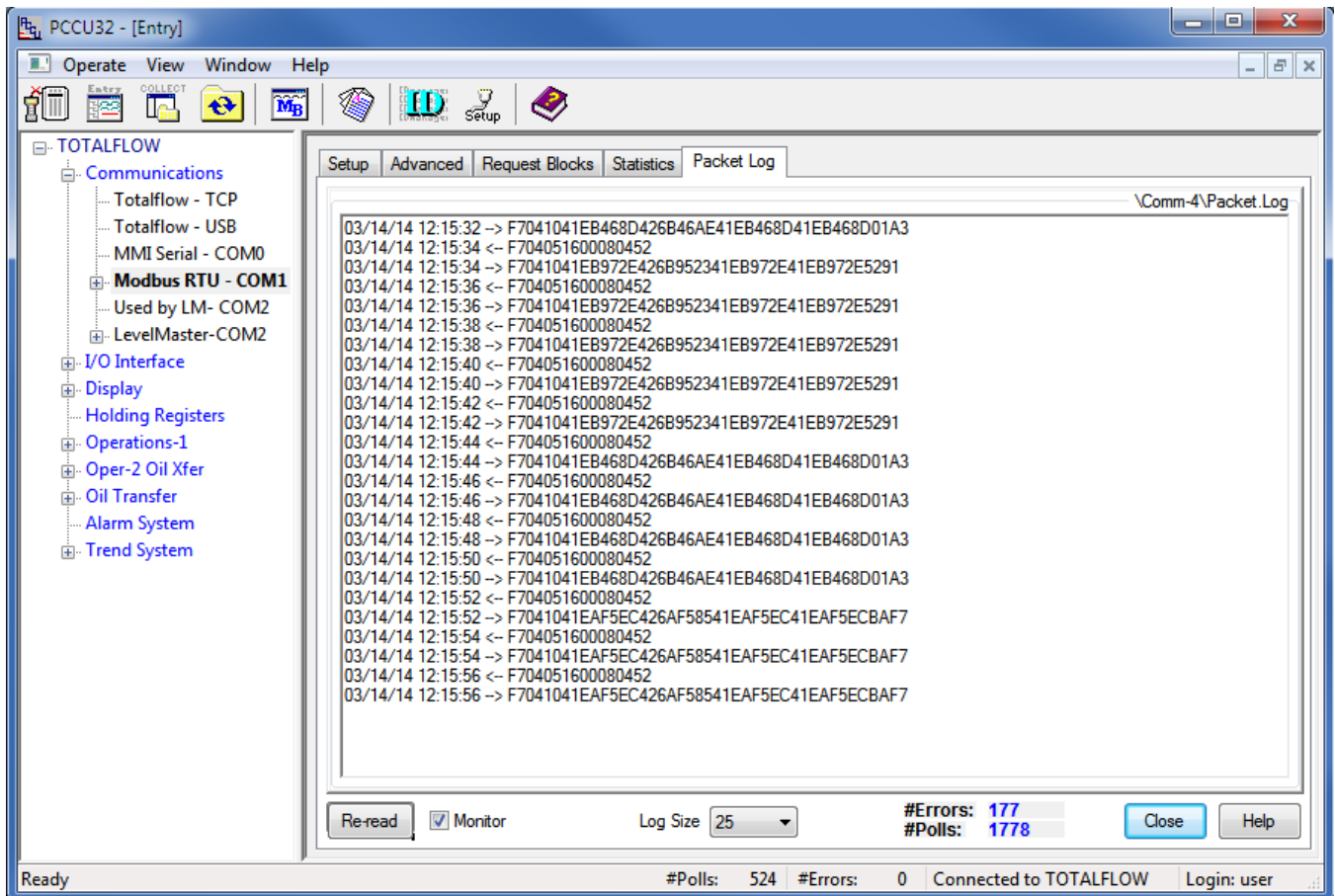

15.4.24 Set the Log Size to 25, and check the Monitor checkbox. The log should start updating with the XRC commands being sent out and the responses from the HMA.

15.4.25 Right-click in the clear area between the Monitor checkbox and the Log Size drop-down. Select a shorter interval screen refresh interval if desired

15.4.26 To display the values,

15.4.27 Select Holding Registers from the tree-view window of the PCCU32.

15.4.28 Select the Dynamic Variables tab.

15.4.29 Click on Re-read to obtain a single set of readings from the HMA, or check the Monitor checkbox to repeatedly read values from the HMA at the Interval specified in the Request Blocks tabs in step 15.4.29.

## 15.5. Writing registers to the HMA

- 15.5.1 The followings steps demonstrate how to change a parameter in a HART device attached to the HMA. When making any changes to the settings, click on Send at the bottom of the window to write them to the XRC.
- 15.5.2 Select Holding Registers from the tree-view window of the PCCU32.
- 15.5.3 Select the Capacity tab.

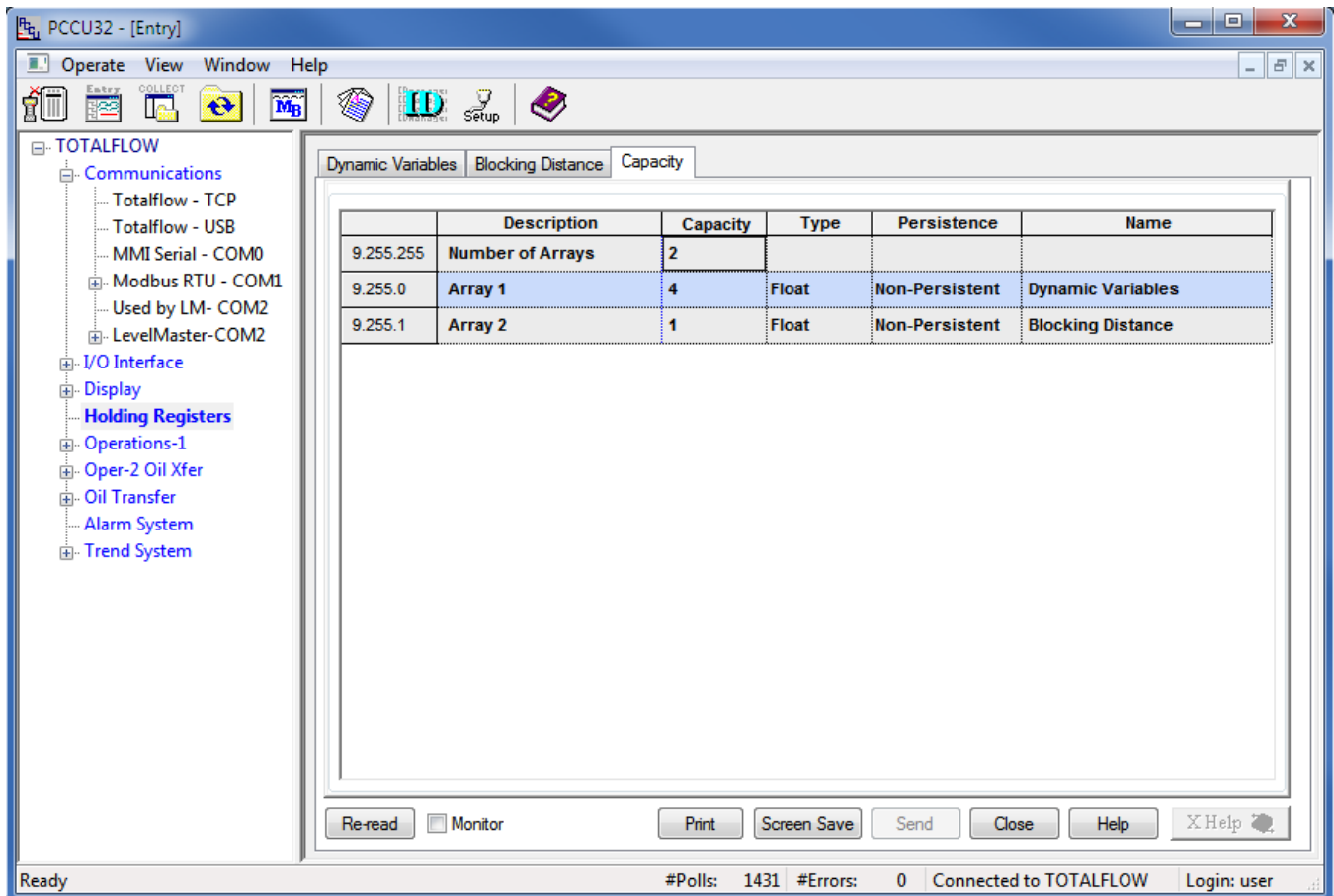

- 15.5.4 Set the Capacity for the Number of Arrays to 2.
- 15.5.5 Set the Capacity for Array 2 to '1', the Type to 'Float', the 'Persistence' to 'Non-Persistent', and the Name to 'Blocking Distance'.

15.5.6 Select the Blocking Distance tab.

15.5.7 Change the description of the four registers to 'Blocking Distance'.

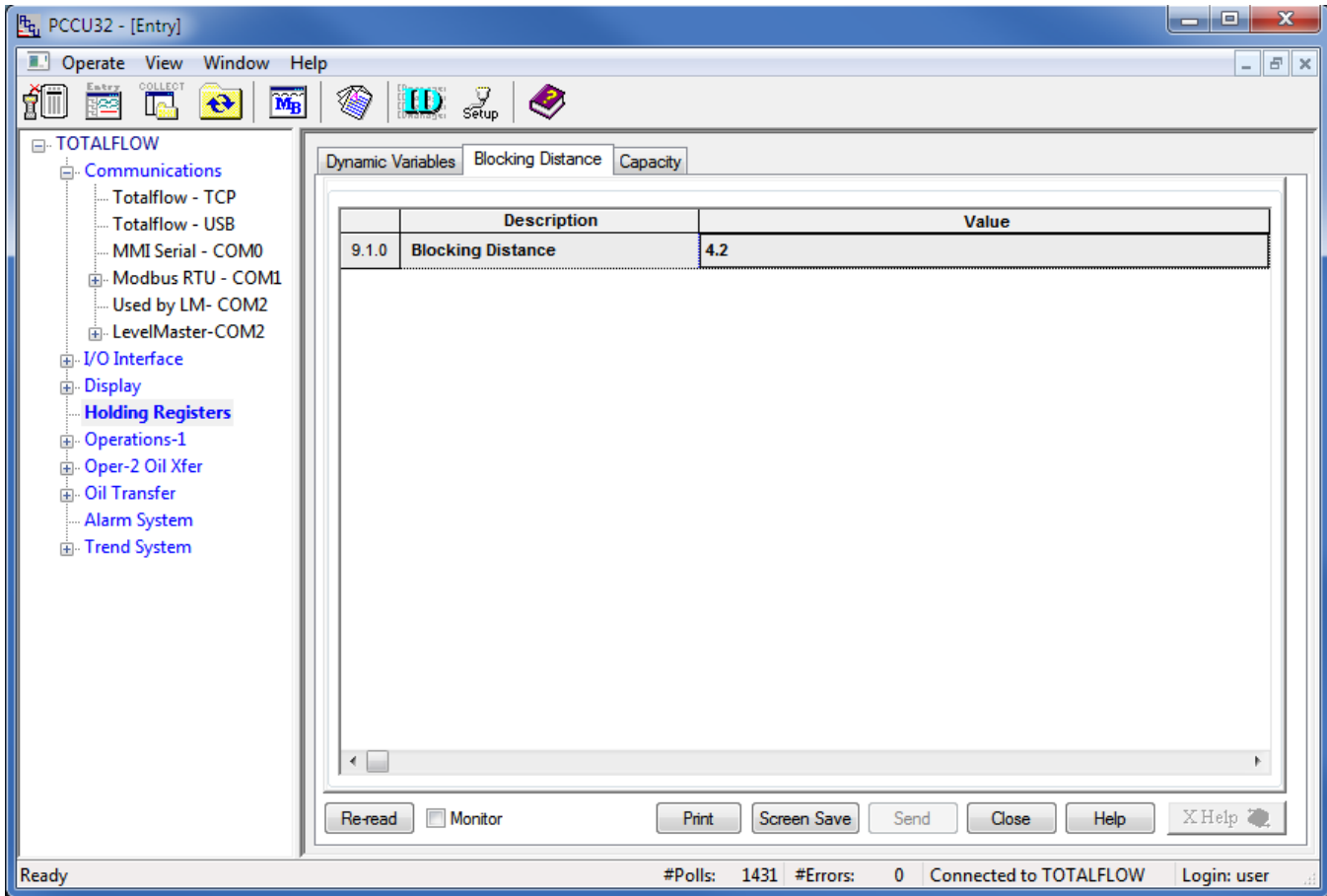

15.5.8 Note the Register number displayed in the first column of the table. It will be used when setting the Request Block in a later step.

15.5.9 Select Communications \ Modbus RTU in the tree-view window.

15.5.10 For the Setup tab,

15.5.11 Ensure that the Protocol and Baud Rate match the selections made in step 15.1.1.

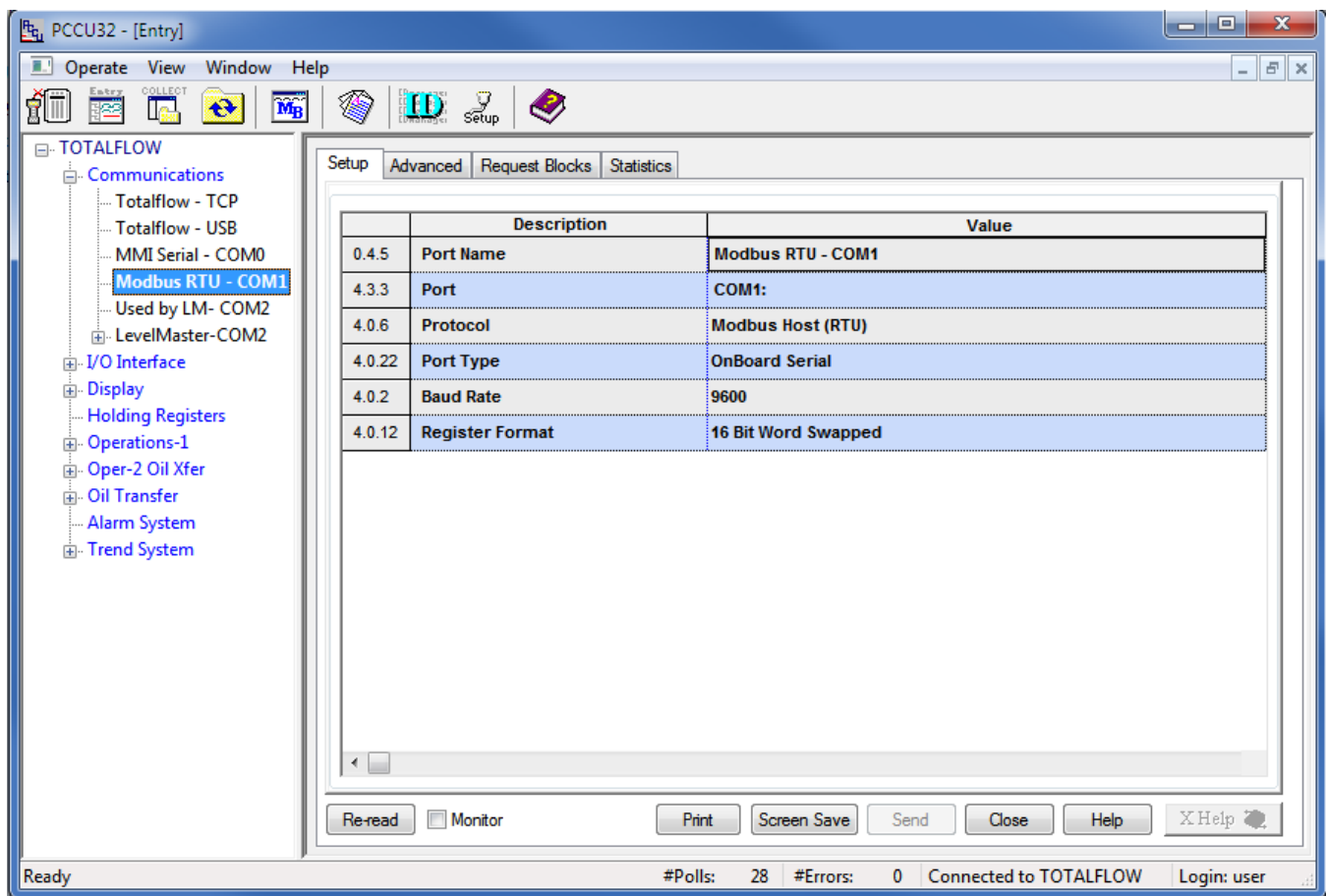

15.5.12 For the Advanced tab,

15.5.13 Ensure that the Data Bits, Parity and Stop Bits match the selections made in step 15.1.1.

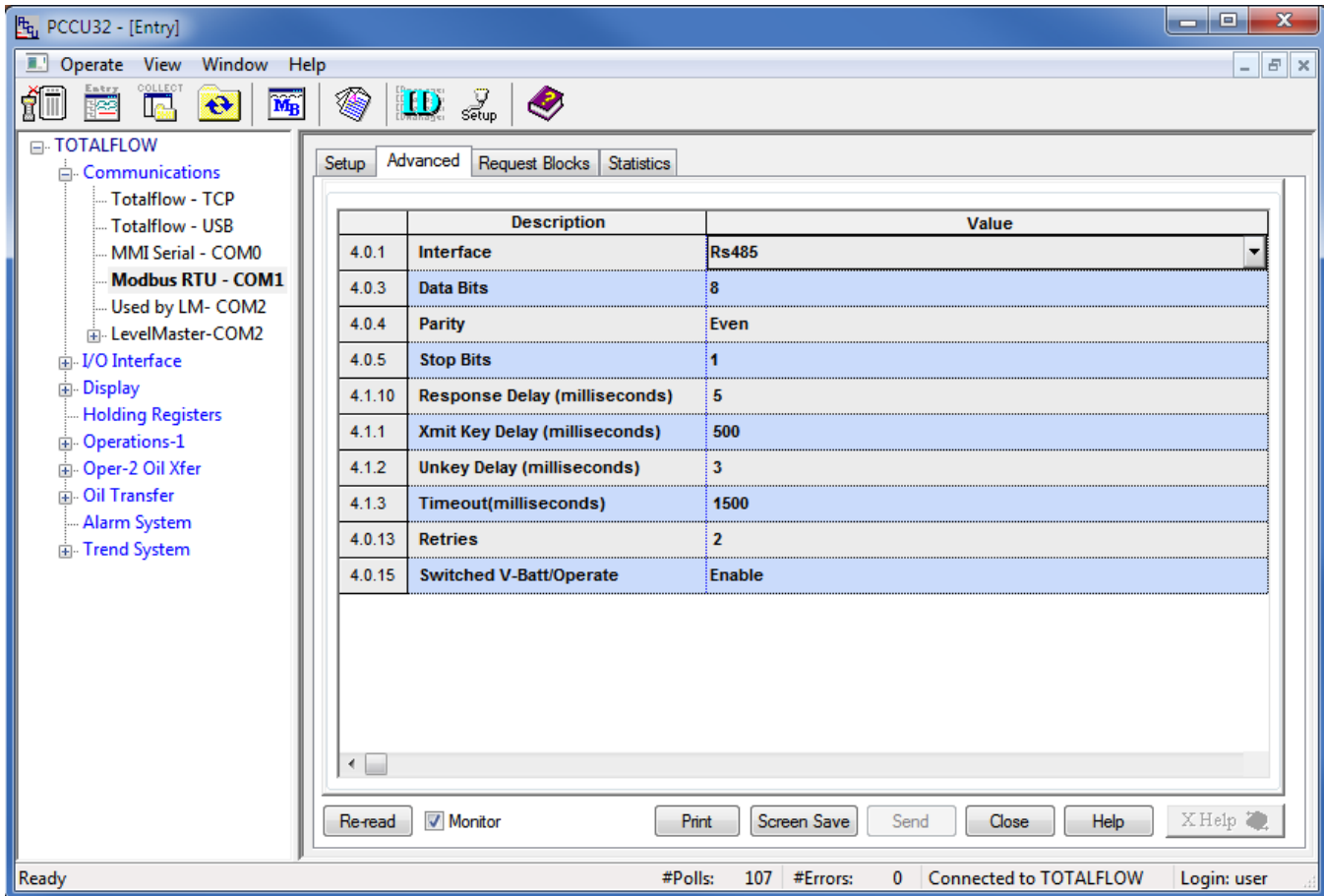

15.5.14 Ensure that the Unkey Delay is less than 7 milliseconds as the HMA typically responds within about 8 milliseconds. If the Unkey Delay time is too long, the XRC will start listening for a response after the HMA has already started transmitting. As a result, the XRC will not recognize the response.

- 15.5.15 For the Request Blocks tab,
- 15.5.16 Select '6 – Write Single Register' from the Modbus function drop-down.
- 15.5.17 Set the Slave Address to match the address of the HMA (if in HMA mode), or an attached device (if in Device mode).
- 15.5.18 Set the Starting Register to a value 1 greater than the desired starting Modbus register. Refer to Appendices F through O for register numbers of the HMA and attached HART devices.

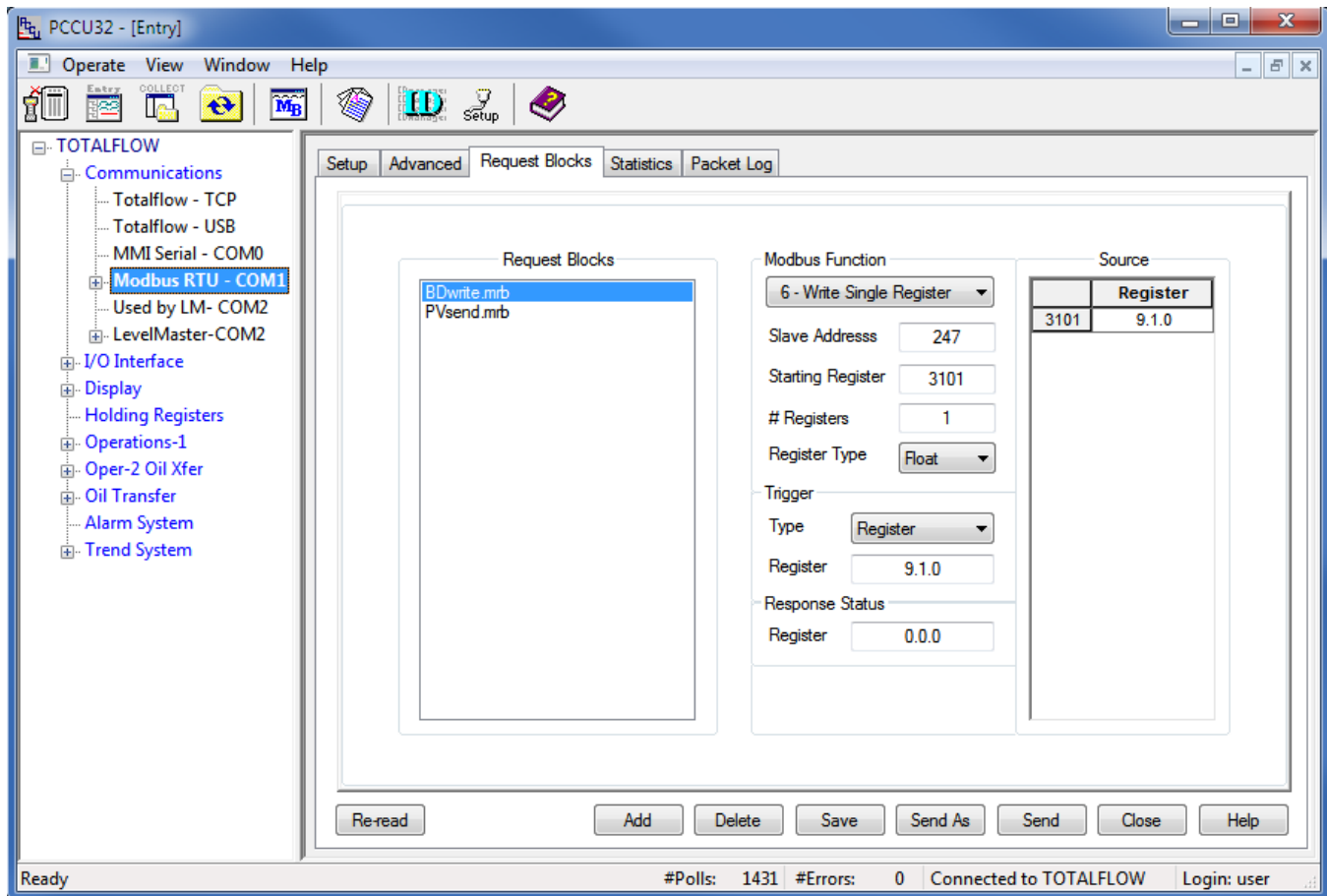

- 15.5.19 Set the # Registers to 1. Note that in this case, 1 float value is to be written so that a value of 1 is entered even though the total number of 16-bit Modbus registers that will be read is 2.
- 15.5.20 Set the Register Type to Float.
- 15.5.21 Set the Trigger Type to Register and the Register number to the register number from step 15.5.8.
- 15.5.22 Set the Source to the register number from step 15.5.8.

15.5.23 Select Holding Registers from the tree-view window of the PCCU32.

15.5.24 Select the Blocking Distance tab.

15.5.25 Change the Value to the desired distance.

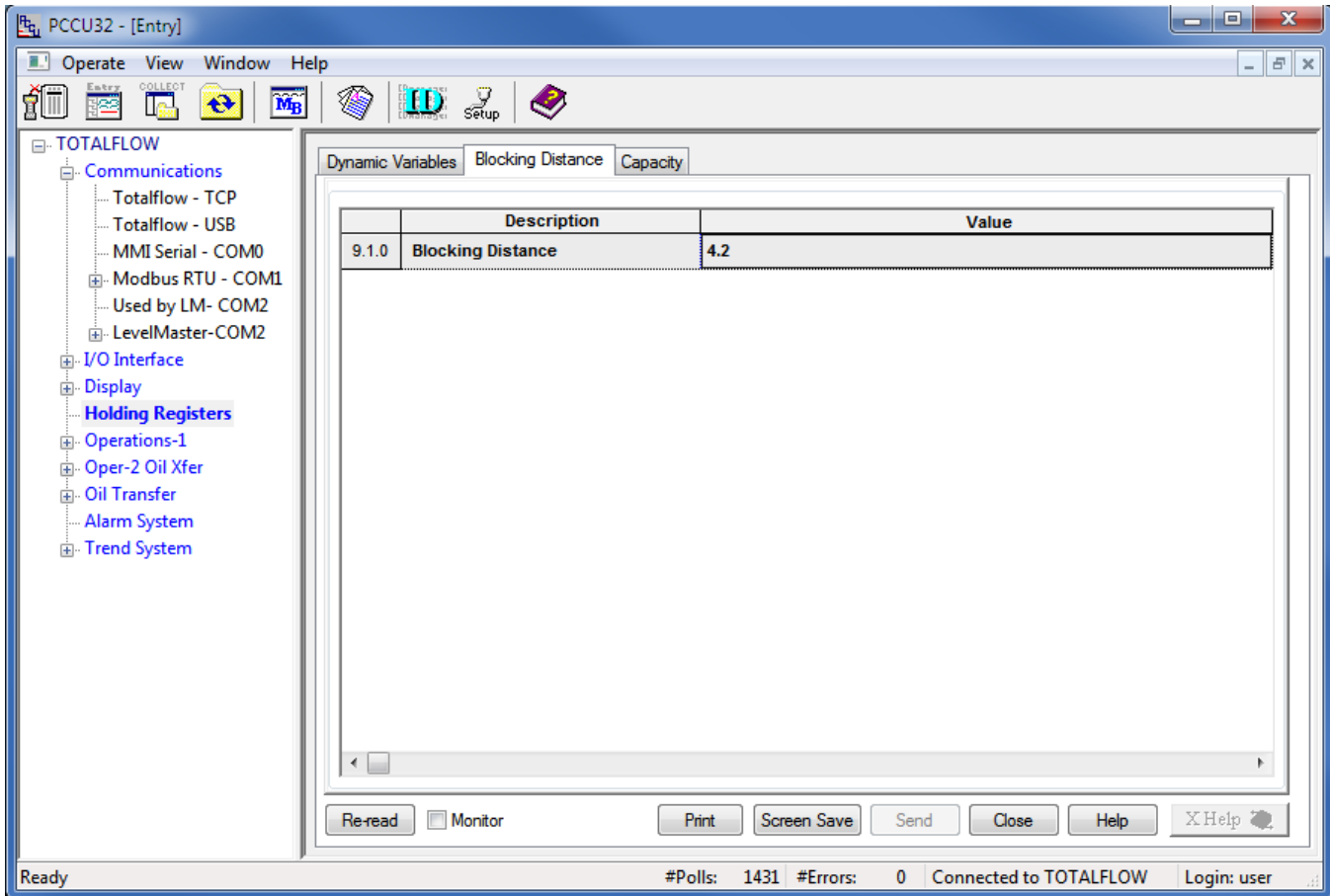

15.5.26 Click on Send at the bottom of the window.

15.5.27 To check if the value has been accepted, follow the steps in section 15.4 changing selections as needed to read the Blocking Distance parameter from the HMA or attached HART device.



## 16. ABB Totalflow XRC – LevelMaster

The ABB Totalflow XRC is only capable of sending and receiving command Uxx?. Note that with the LevelMaster protocol, the HMA operates only in the Device mode. Therefore, the ID in the request blocks must be set to the attached HART device's Poll Address rather than that of the HMA. The XRC displays the first float returned by Command Uxx? as Level 1 (the Upper Level for Magnetrol Devices) and the second float as Level 2 (typically the Interface Level for Magnetrol devices). Accordingly, it is recommended to configure the attached Magnetrol HART device for PV as Level, and SV as Interface level.

### 16.1. Initial HMA Configuration

- 16.1.1 Using Procedure 1, ensure that registers 3000 through 3007 of the HMA match the values shown for LevelMaster communication with the ABB TotalFlow XRC. Refer to Appendix F for the HMA Communication settings. If the settings do not match, double-click on a value that needs to be changed in order to open the Write Single Register dialog, enter the new value, and then click on Send.

### 16.2. Physical Connections

- 16.2.1 Connect the ABB Totalflow XRC to a computer using USB-A to USB-B cable.
- 16.2.2 Connect an appropriate power supply to the battery charging terminal (J17) of the ROC 800.
- 16.2.3 Connect the HMA to a 9 – 30 VDC power supply via terminal block TB1.
- 16.2.4 Connect an RS-485 communications cable between the RS-485 module of the ROC 800 and the RS-485 terminal block (TB2) of the HMA.
- 16.2.5 Connect a 120 $\Omega$  resistor between the two RS-485 terminal block positions of the last HMA on the bus.

### 16.3. Initial XRC Configuration

- 16.3.1 Start the PCCU32 application.
- 16.3.2 Select on Operate \ Setup \ System Setup in the PCCU32 Menu bar. A dialog will appear allowing for communication settings between the PCCU32 application and the XRC.

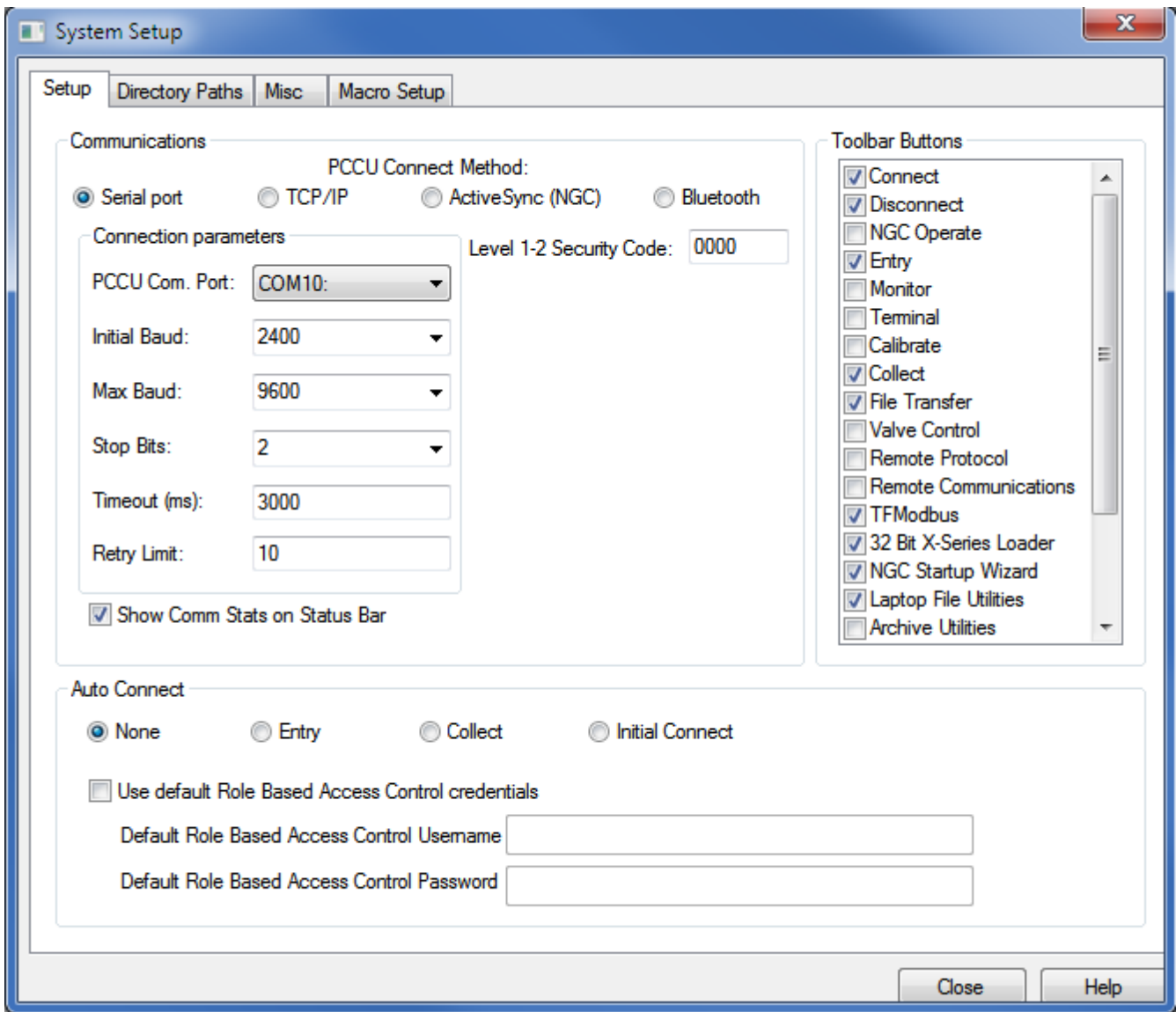

- 16.3.3 Select the COM port number corresponding to the XRC.
- 16.3.4 Click Close.

16.3.5 Select on Operate \ Connect to Totalflow in the PCCU32 Menu bar.

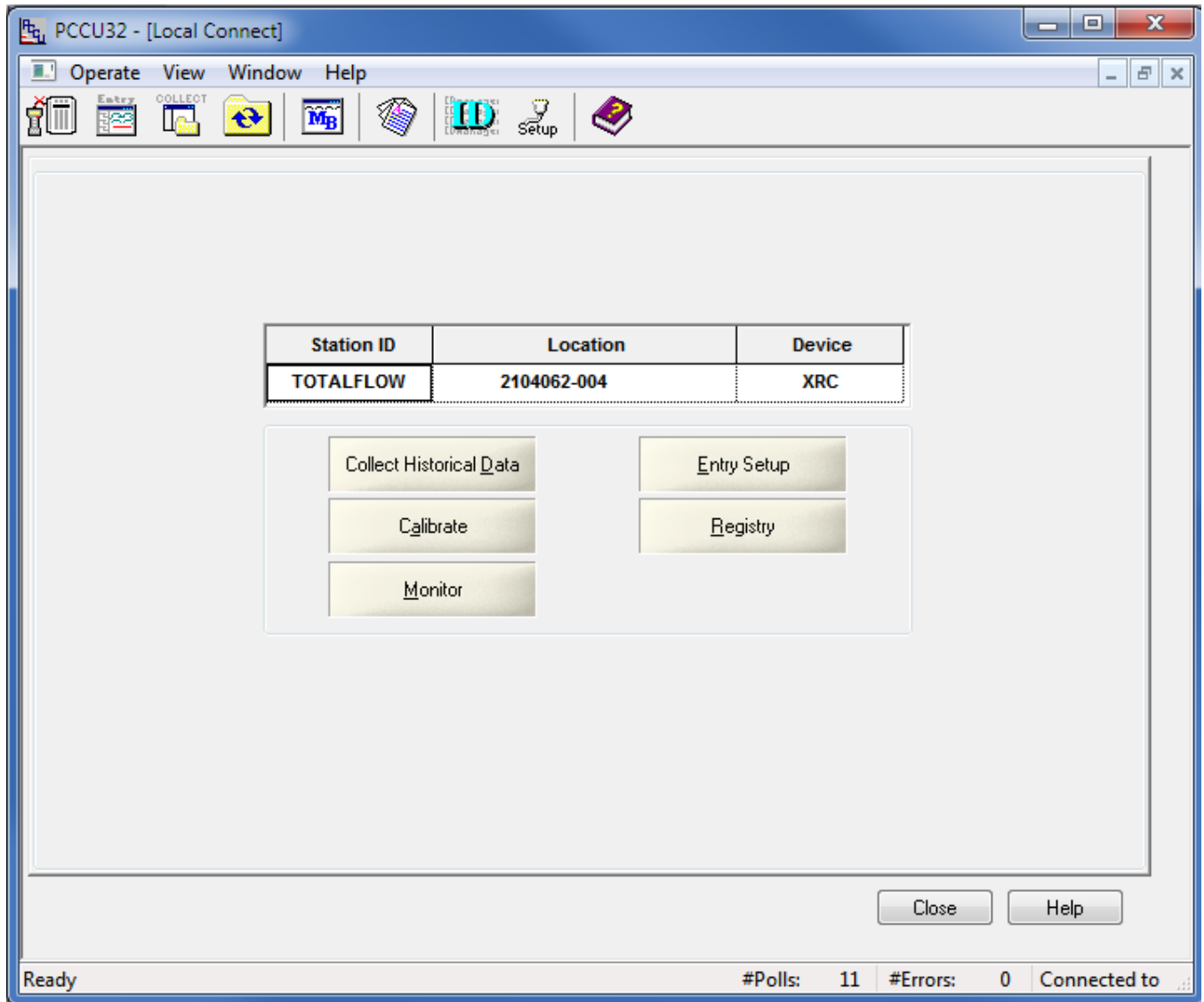

16.3.6 Select Entry Setup from the Local Connect initial dialog.

16.3.7 Select View \ Advanced from the PCCU32 menu bar.

- 16.3.8 Click on Communications in the tree-view window.
- 16.3.9 Click on the Port name associated with Modbus RTU.
- 16.3.10 Select 'Tank Gauge' for the Protocol.
- 16.3.11 Set the Unkey delay to 3 ms.
- 16.3.12 Ensure that the communications settings match the settings of the HMA performed in step 16.1.1, then click OK. For example,

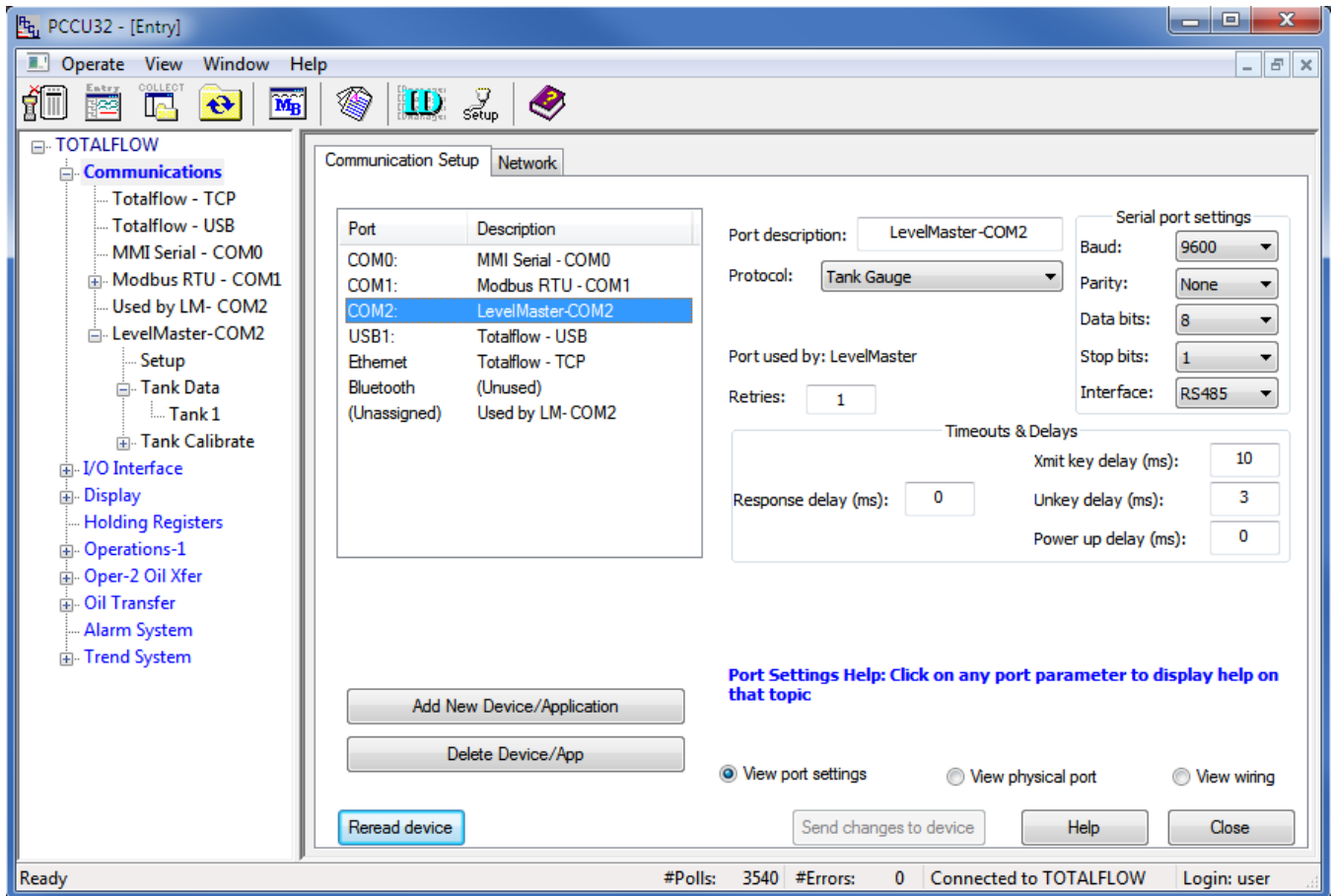

16.3.13 The terminal block connections on the XRC can be verified by clicking on the View Wiring radio button.

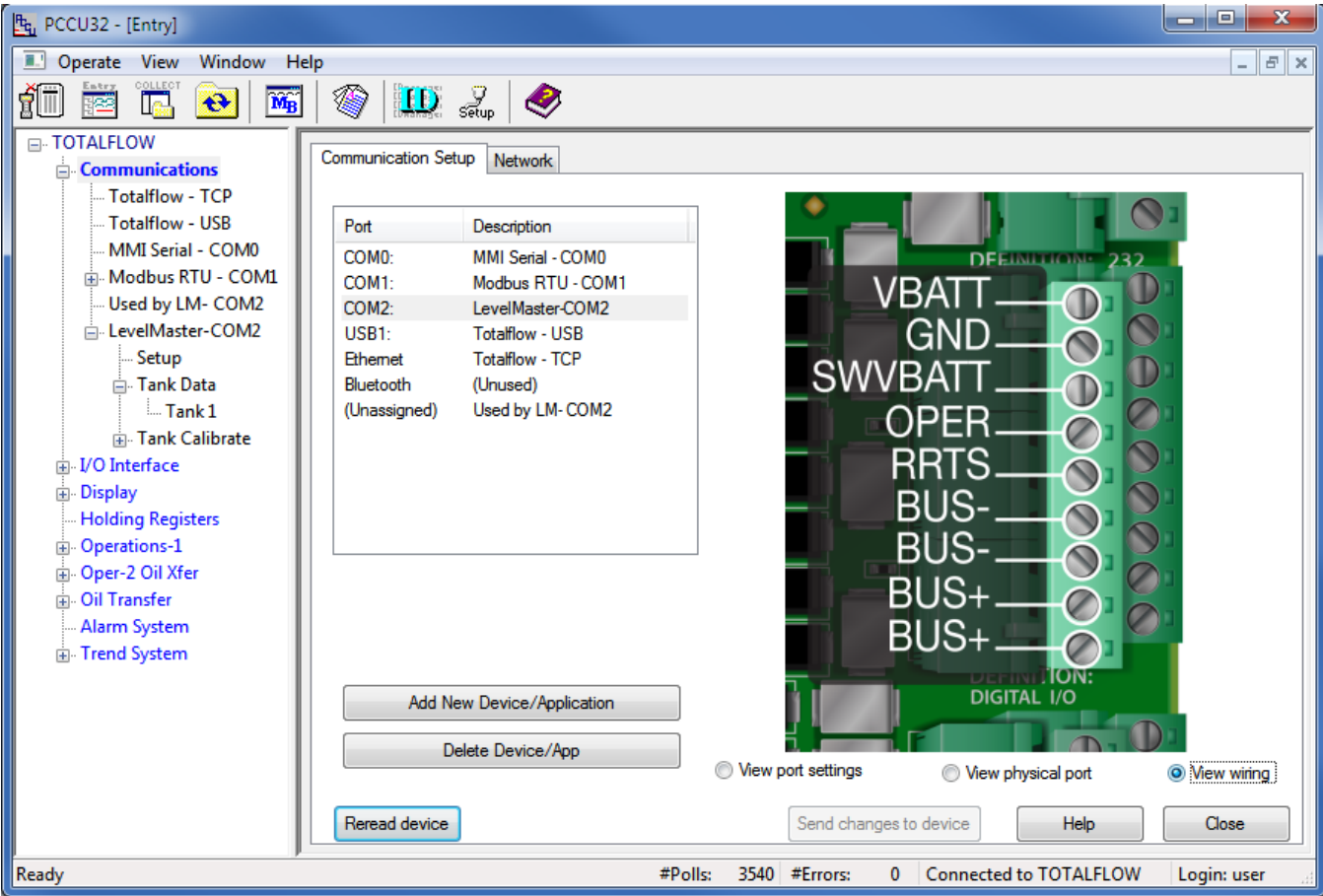

## 16.4. Reading registers from the HMA

- 16.4.1 The followings steps demonstrate how to read the PV, SV, Echo Strength, Errors and Warnings from a HART device attached to the HMA. When making any changes to the settings, click on Send at the bottom of the window to write them to the XRC.
- 16.4.2 Select Communications \ LevelMaster \ Setup in the tree-view window of the PCCU32.
- 16.4.3 For the Setup tab,
- 16.4.4 Set the Number of Tanks to the number of attached HART devices to be read.

The screenshot shows the PCCU32 software interface. The left pane displays a tree view under 'TOTALFLOW' with 'LevelMaster-COM2' selected and the 'Setup' sub-tab active. The main window has tabs for 'Setup', 'Communications', 'Request Blocks', 'Statistics', and 'Packet Log'. The 'Setup' tab contains a table with the following data:

	Description	Value
0.4.52	Device/APP ID	LevelMaster-COM2
51.107.0	Number of Tanks	1

At the bottom of the window, there are buttons for 'Re-read', 'Monitor', 'Print', 'Screen Save', 'Send', 'Close', 'Help', and 'X Help'. The status bar at the very bottom shows: 'Ready #Polls: 3545 #Errors: 0 Connected to TOTALFLOW Login: user'.

16.4.5 For the Communications tab,

16.4.6 Ensure that the communication settings match the selections made in steps 16.1.1 and 16.3.12.

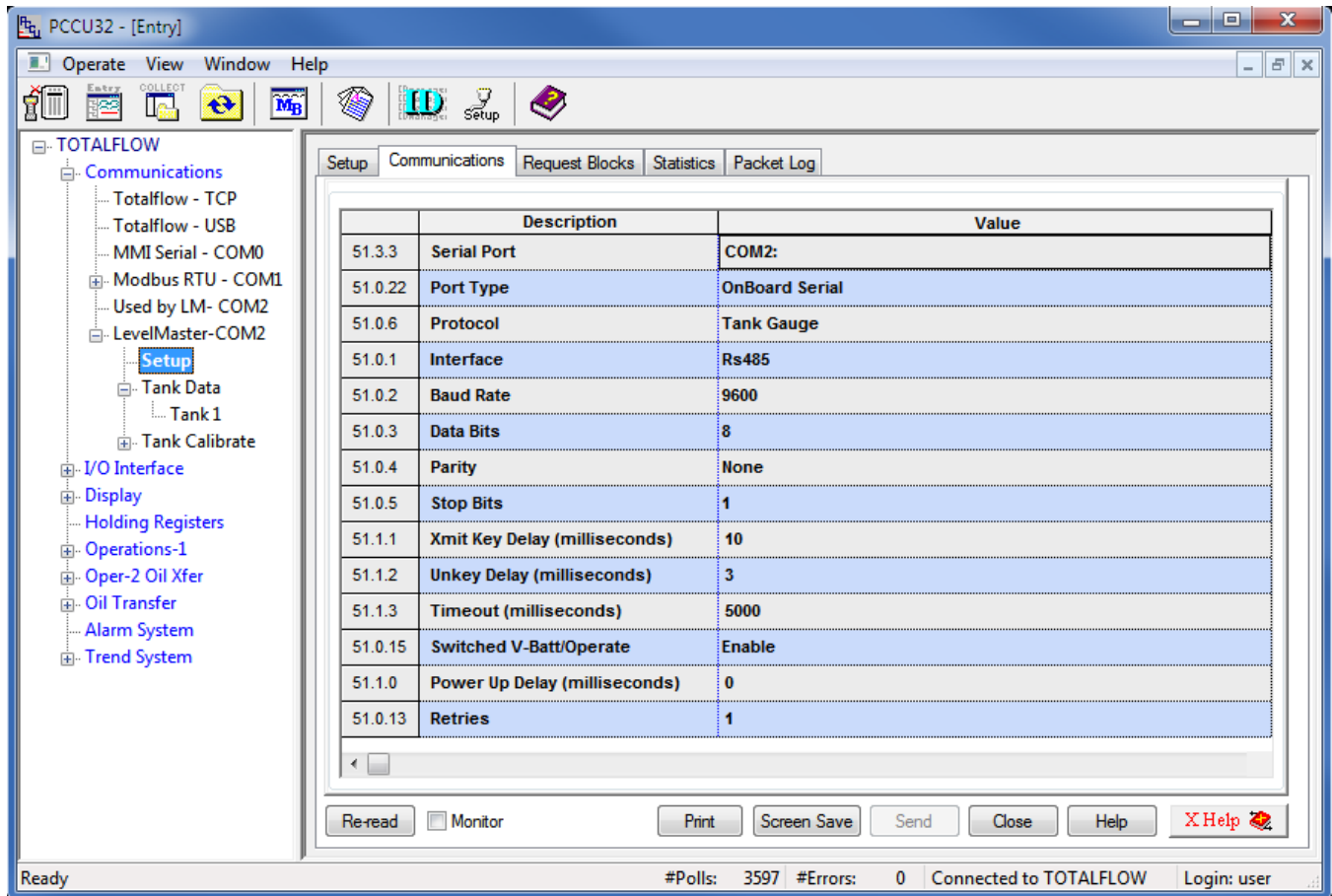

- 16.4.7 For the Request Blocks tab,
- 16.4.8 In the Auto Config group menu, set the Application to 51, the Tank Num. to the appropriate value for the attached HART device, and the Sensor to 'Dual Level'. The HMA always returns a Dual Level response to Command Uxx? in order to provide data for the SV output of the attached HART device.
- 16.4.9 In the Registers group menu, set the ID to the Poll Address of the attached HART device to be read for that Tank Num. (Note that due to limitations of the LevelMaster protocol, the HMA only operates in the Device mode for that protocol.)

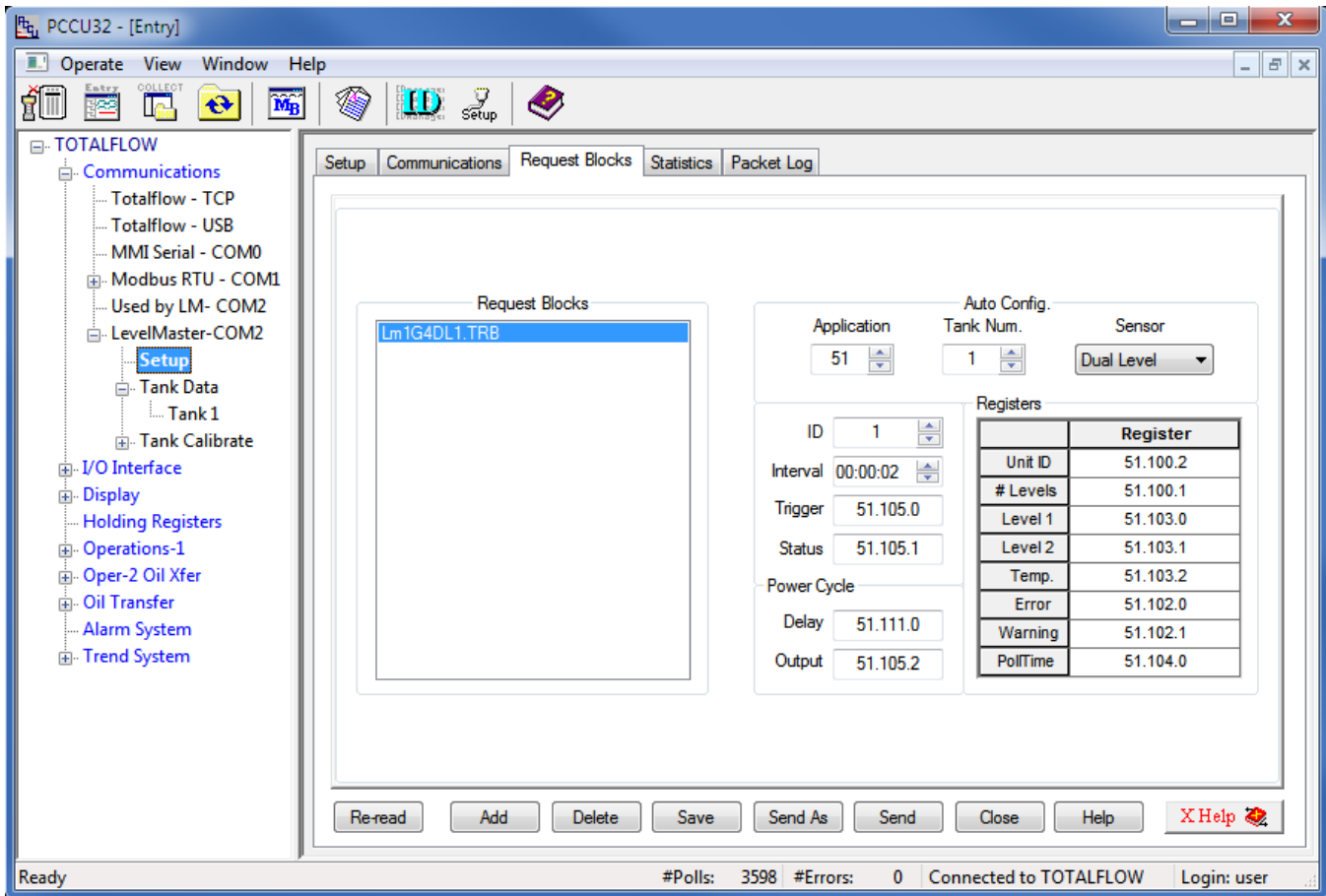



- 16.4.10 To check if transmissions and responses are being made, select View \ Expert from the PCCU32 Menu bar. This mode displays a Packet Log tab when selecting Communications \ Modbus RTU from the tree-view window.
- 16.4.11 Set the Log Size to 25, and check the Monitor checkbox. The log should start updating with the XRC commands being sent out and the responses from the HMA.
- 16.4.12 Right-click in the clear area between the Monitor checkbox and the Log Size drop-down. Select a shorter interval screen refresh interval if desired.

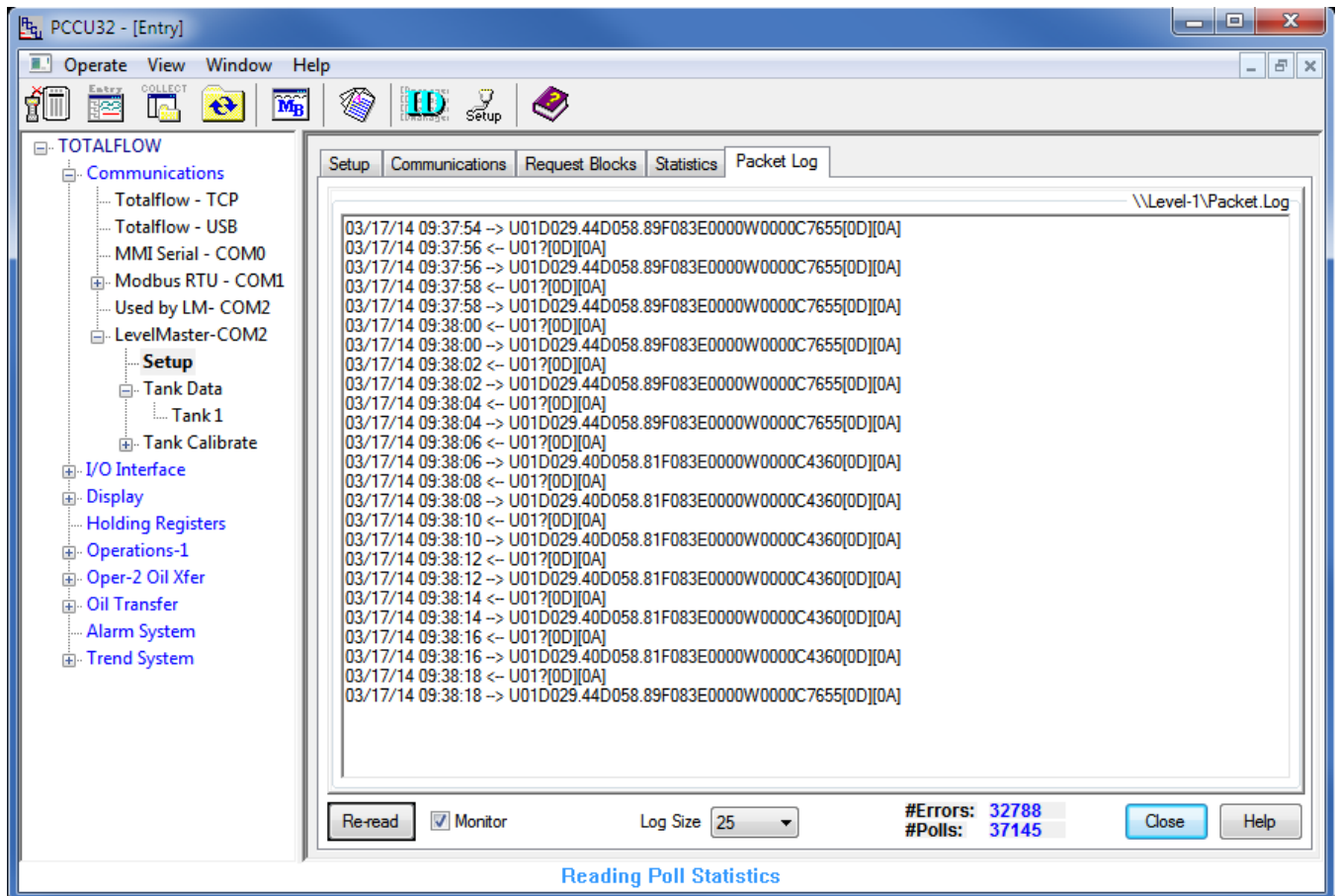

16.4.13 To display the values,

16.4.14 Select Communications \ LevelMaster \ Tank Calibrate \ Tank x from the tree-view window of the PCCU32.

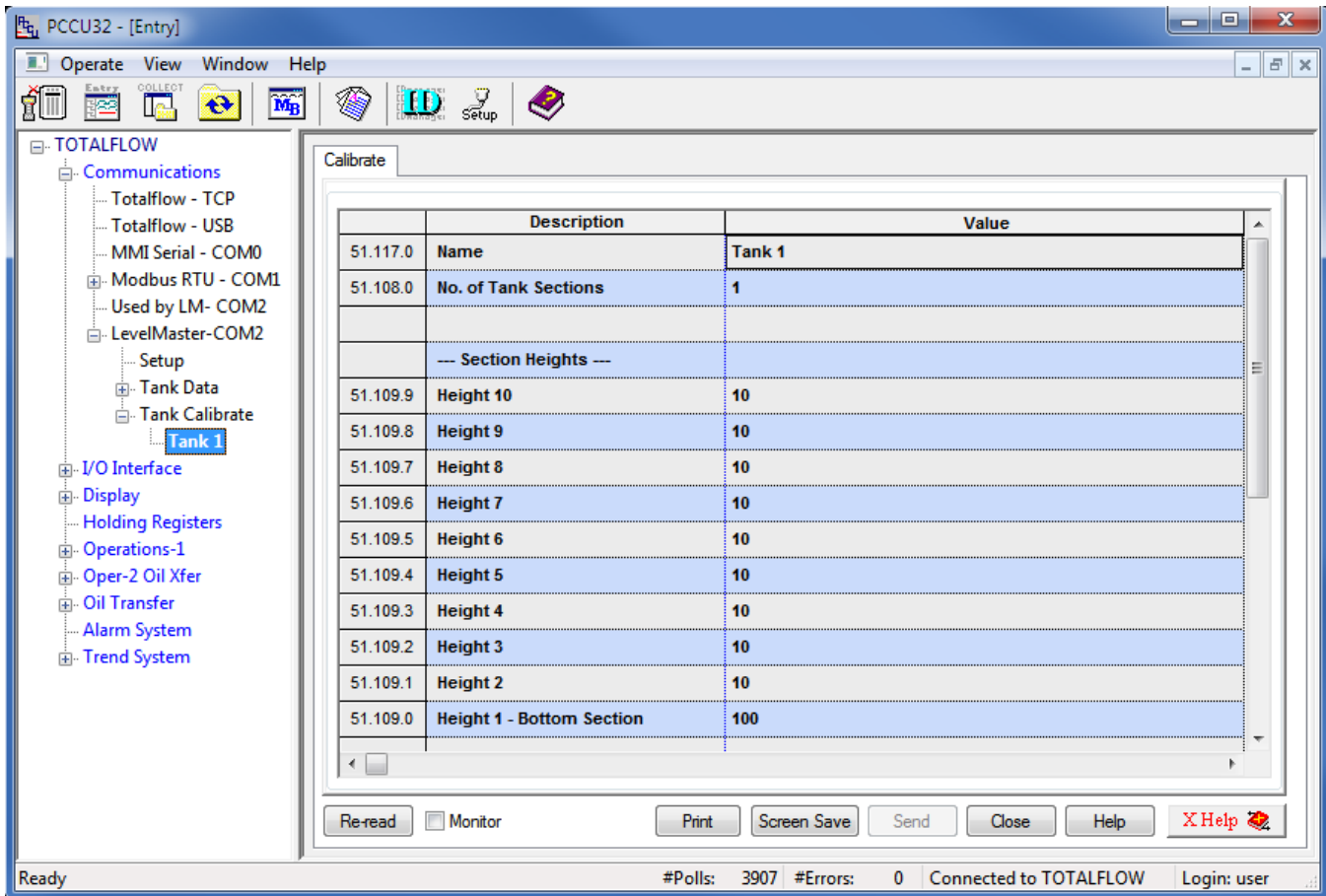

16.4.15 Set the number of Tank Sections in row 51.108.x.

16.4.16 For each tank section, set the height of that section in rows 51.109.x

16.4.17 For each tank section, enter the Factor in rows 51.110.x. The Factor value is the number of barrels per ¼ inch of height in that section. By clicking on the Help button of the PCCU32 and searching for 'tank calibration', a more detailed explanation of the calibration process can be obtained.

16.4.18 Select Communications \ LevelMaster from the tree-view window of the PCCU32.

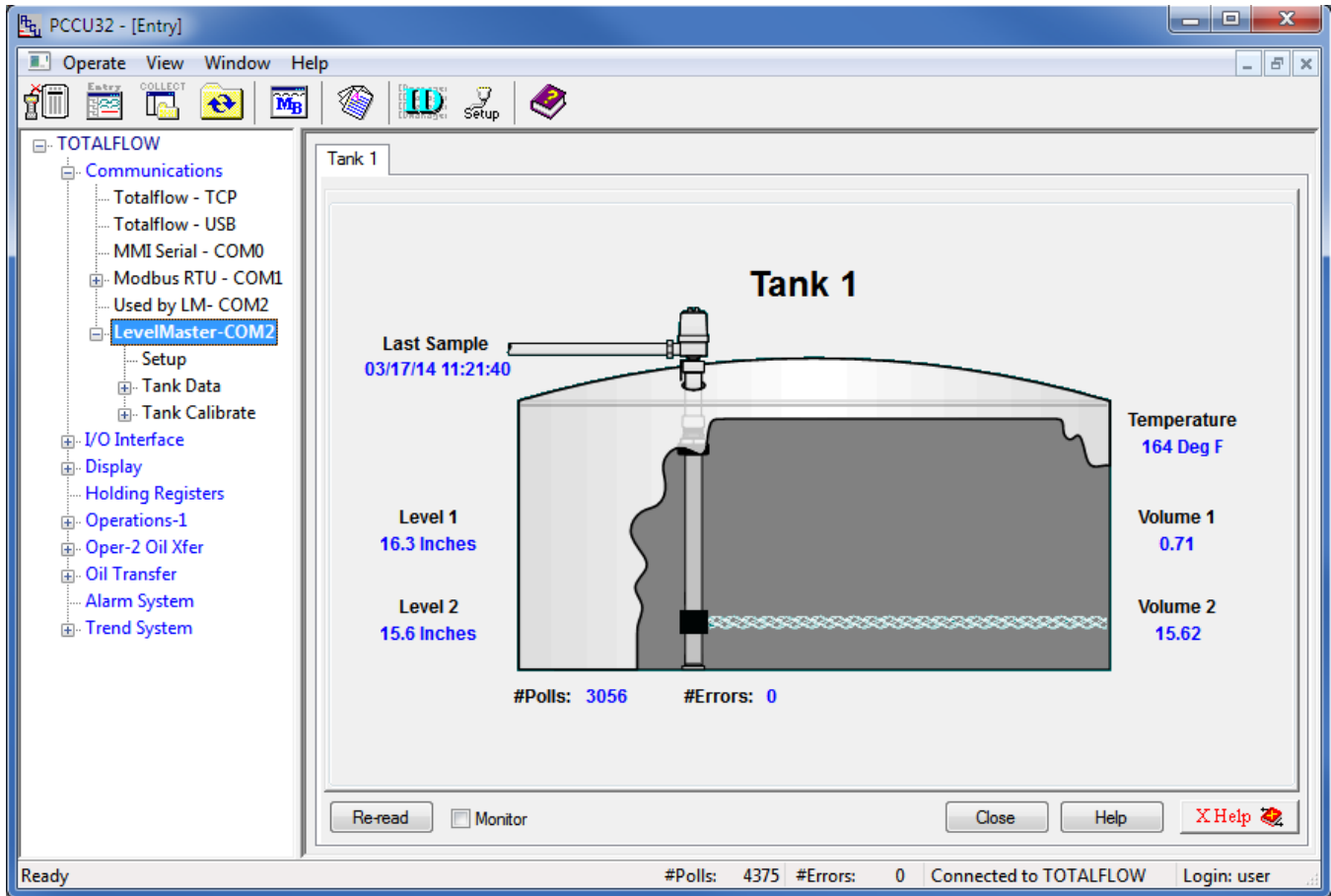

16.4.19 Click on Re-read to obtain a single set of readings from the HMA, or check the Monitor checkbox to repeatedly read values from the HMA at the Interval specified in the Request Blocks tabs in step 16.4.9.

16.4.20 In the example above, the attached device has the Measurement Type set to Interface, the PV set to the Level reading and SV set to the Interface Level reading. The level reading from the device (PV is sent as Float 1 of Command Uxx?) is displayed as Level 1. The Interface Level reading from the device is displayed as Level 2. The Echo Strength from the device is displayed as the Temperature. The Volume 1 value is computed from the difference between the Level 1 and Level 2 readings. The Volume 2 value is computed from the Level 2 reading. The level to volume conversion is determined by the settings made in steps 16.4.15 through 16.4.17.

16.4.21 If the Measurement Type of the device is set to Level, the Level1 and Level 2 readings will be the same, Volume 1 will always be 0 and Volume 2 will represent the total volume.

16.4.22 Any Errors or Warnings from the attached HART device will appear under the bottom right section of the tank image.

## 16.5. Writing registers to the HMA

The ABB Totalflow XRC has no provisions for sending commands to LevelMaster devices other than the Uxx? command. Therefore, it is not possible to write registers in the attached HART devices.

## 17. ThermoScientific AutoPILOT PRO – Modbus RTU / ASCII

The following procedure applies to operation with both RTU and ASCII communication. The choice of communication protocol is made in step 4.1.8 for the HMA settings, and step 4.3.10. The Modbus RTU protocol is used for the following.

### 17.1. Initial HMA Configuration

- 17.1.1 Using Procedure 1, ensure that registers 3000 through 3007 of the HMA match the values shown for LevelMaster communication with the AutoPilot Pro. Refer to Appendix F for the HMA Communication settings. If the settings do not match, double-click on a value that needs to be changed in order to open the Write Single Register dialog, enter the new value, and then click on Send.

### 17.2. Physical Connections

- 17.2.1 Connect the AutoPILOT PRO to a computer using a CHIT computer connection cable for (ThermoScientific p/n 3-0446-090).
- 17.2.2 Connect an appropriate 12 VDC power supply to the terminals of TB-1 on the inside of the AutoPILOT PRO front panel.
- 17.2.3 Connect an RS-485 communications cable between the terminals of TB-16 of the AutoPILOT PRO and the RS-485 terminal block (TB2) of the HMA. The TX/RX+ terminal of the HMA should be connected to the TX+ terminal of TB-16. The TX/RX- terminal of the HMA should be connected to the TX- terminal of TB-16.
- 17.2.4 On the main board of the AutoPILOT PRO, add a jumper to pins 15-16 of J39 to select 2-wire mode.
- 17.2.5 On the main board of the AutoPILOT PRO, add a jumper to J40 to select RS-485 mode.
- 17.2.6 Connect a 120Ω resistor between the two RS-485 terminal block (TB2) positions of the last HMA on the bus.

### 17.3. Initial AutoPILOT PRO Configuration

- 17.3.1 Start the AutoCONFIG application.
- 17.3.2 A dialog will appear allowing for communication settings between the AutoCONFIG application and the AutoPILOT PRO. This example uses 'Local Connection' as the connection profile name.

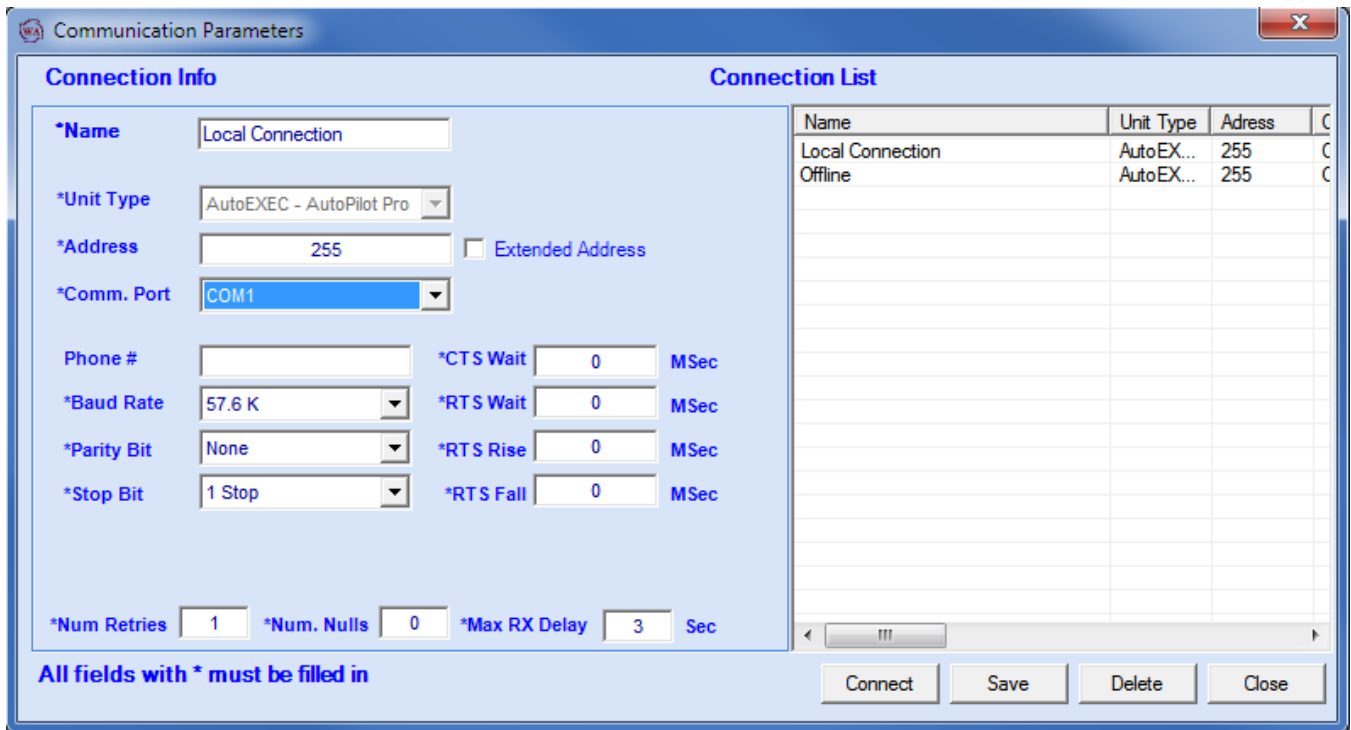

- 17.3.3 Select the COM port number corresponding to the CHIT cable.
- 17.3.4 Ensure that the other communication settings are set as desired. Note: The settings displayed above have been found to result in successful connection to the AutoPILOT PRO.
- 17.3.5 If any changes to the settings have been made, click on Save.
- 17.3.6 Click on Connect to establish communication with the AutoPILOT PRO.

## 17.4. Reading registers from the HMA

17.4.1 The followings steps demonstrate how to read the PV, SV, TV and QV from a HART device attached to the HMA. When making any changes to the settings, click on Apply at the top of the window to write them to the AutoPilot Pro.

17.4.2 In the Navigation Bar, click on Communication(s), expand the 96-Communication Port(s) item, and then double-click on Host Comm Port.

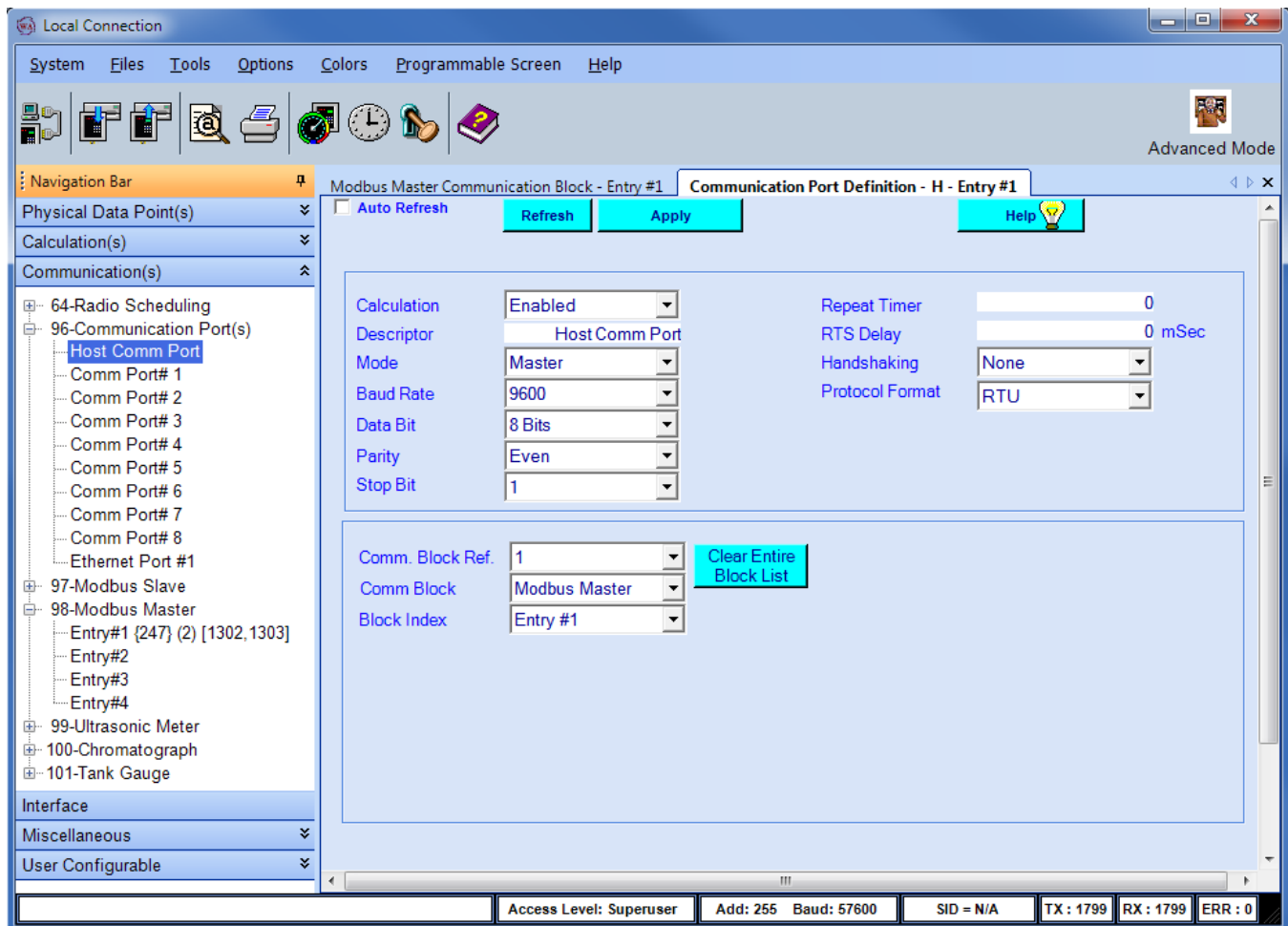

17.4.3 Set Calculation to Enabled.

17.4.4 Set the Repeat Timer to the desired sampling interval in seconds.

17.4.5 Ensure that the communication settings match the selections made in step 17.1.1.

17.4.6 Set the Comm. Block Ref to 1, the Comm Block to Modbus Master, and the Block Index to Entry #1.

17.4.7 Click on Apply to send the settings to the AutoPILOT PRO.

17.4.8 In the Navigation Bar, click on Communication(s), expand the 98-Modbus Master item, and then double-click on Entry#1.

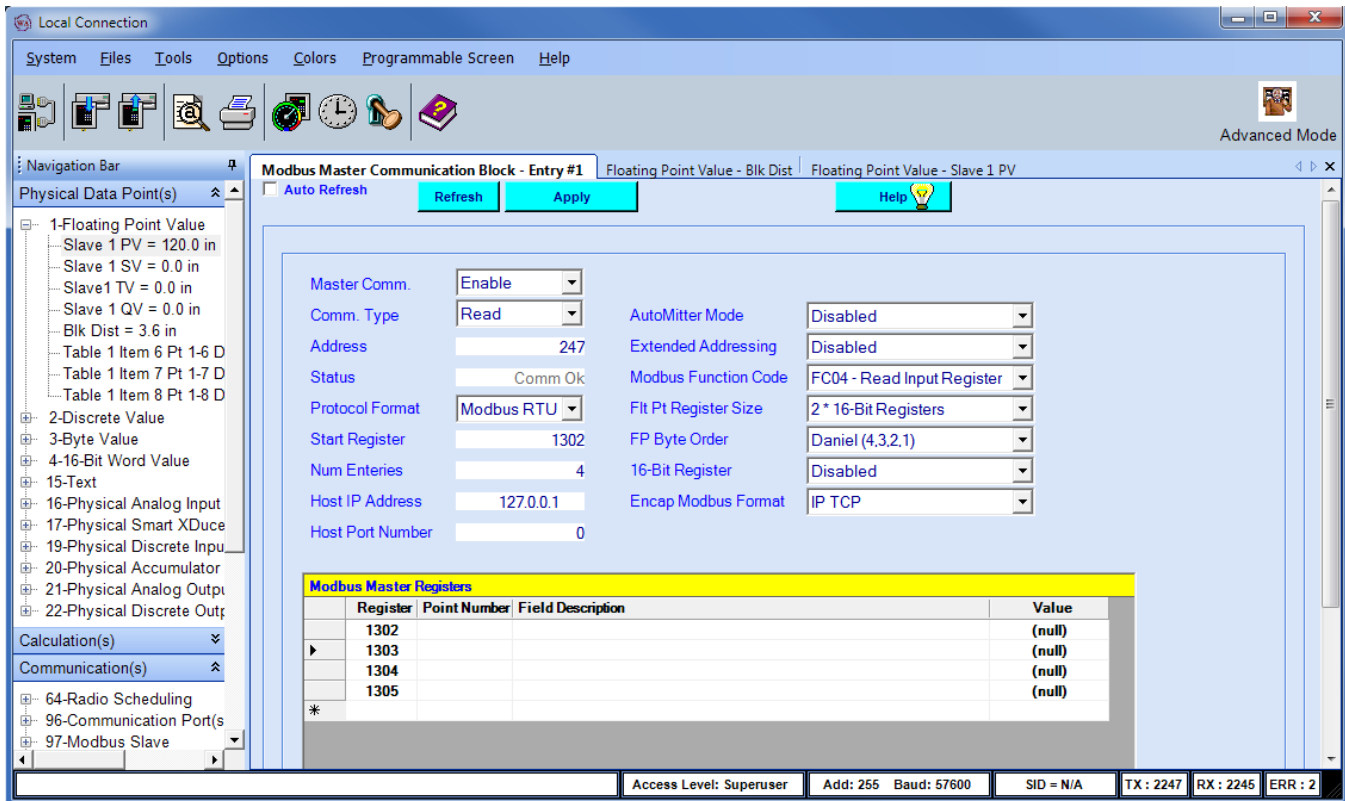

17.4.9 Set Master Comm. to Enable.

17.4.10 Set Comm. Type to Read.

17.4.11 Set the Address to the Modbus address of the HMA.

17.4.12 Set the Start Register to 1302 (the start of the PV register for Slave 1 in the HMA).

17.4.13 Set the Num Entries to 4 (four 32-bit floating point numbers).

17.4.14 The Host IP Address, Host Port Number, AutoMitter Mode, Extended Addressing and Encap Modbus Format can be ignored.

17.4.15 Set the Modbus Function Code to FC04 - Read Input Register.

17.4.16 Set the Fit Pt Register Size to 2 \* 16-Bit register, and the FP Byte Order to Daniel (4,3,2,1).

17.4.17 Set the 16-Bit Register to Disabled.

17.4.18 Click on Apply to send the settings to the AutoPILOT PRO.



- 17.4.19 In the Navigation Bar, click on Physical Data Point(s), and expand the 1-Floating Point Value item.
- 17.4.20 Double click on the Table 1 Item 1 entry, and change Descriptor #1 to 'PV' and Engineering Unit to correspond to the level units in use by the HART transmitter to be read.

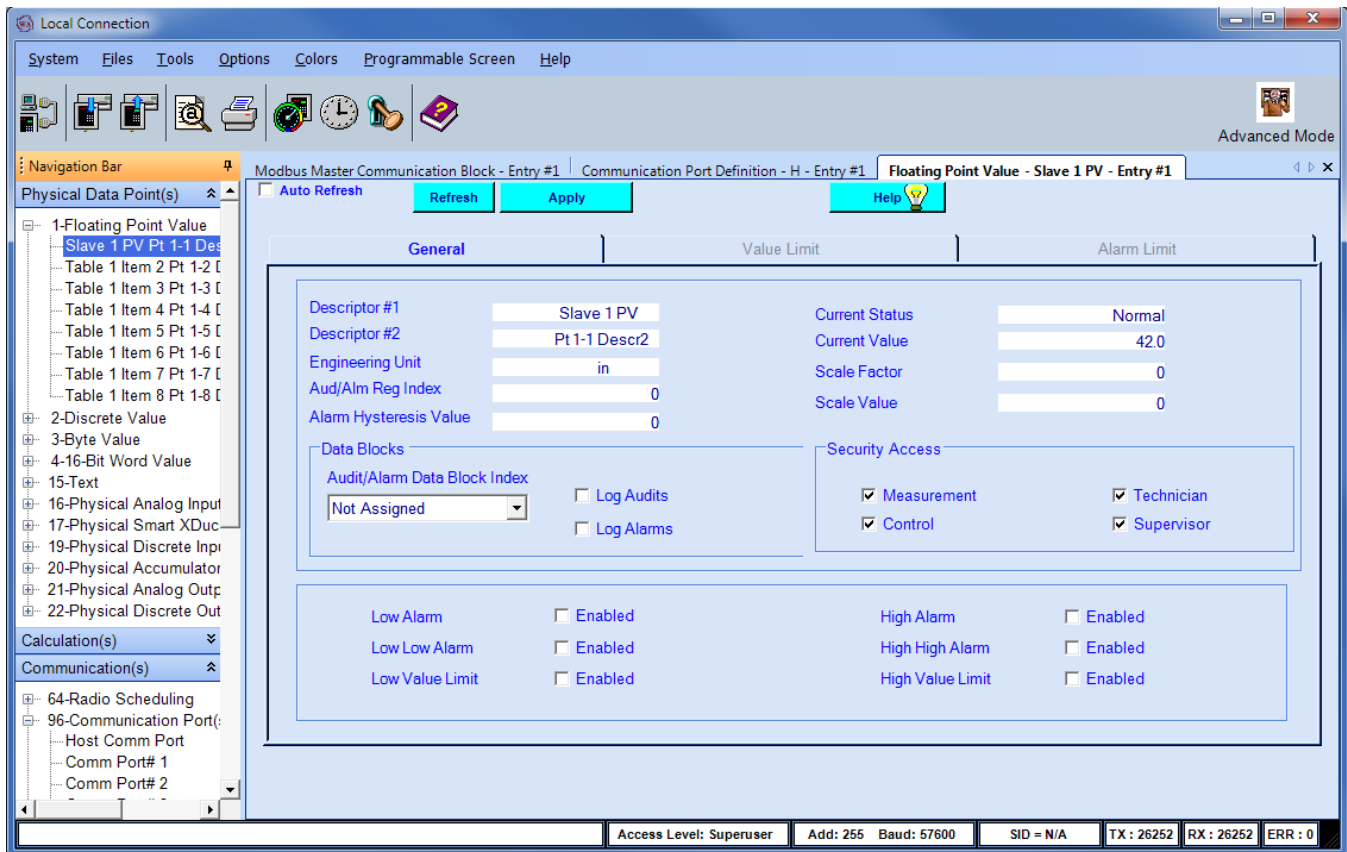

- 17.4.21 Click on Apply to send the settings to the AutoPILOT PRO.
- 17.4.22 Right click on the Slave 1 PV entry in the Navigation Bar and select Copy.

17.4.23 Double click on the Entry #1 listing in the Communication(s) \ 98-Modbus Master section of the Navigation Bar.

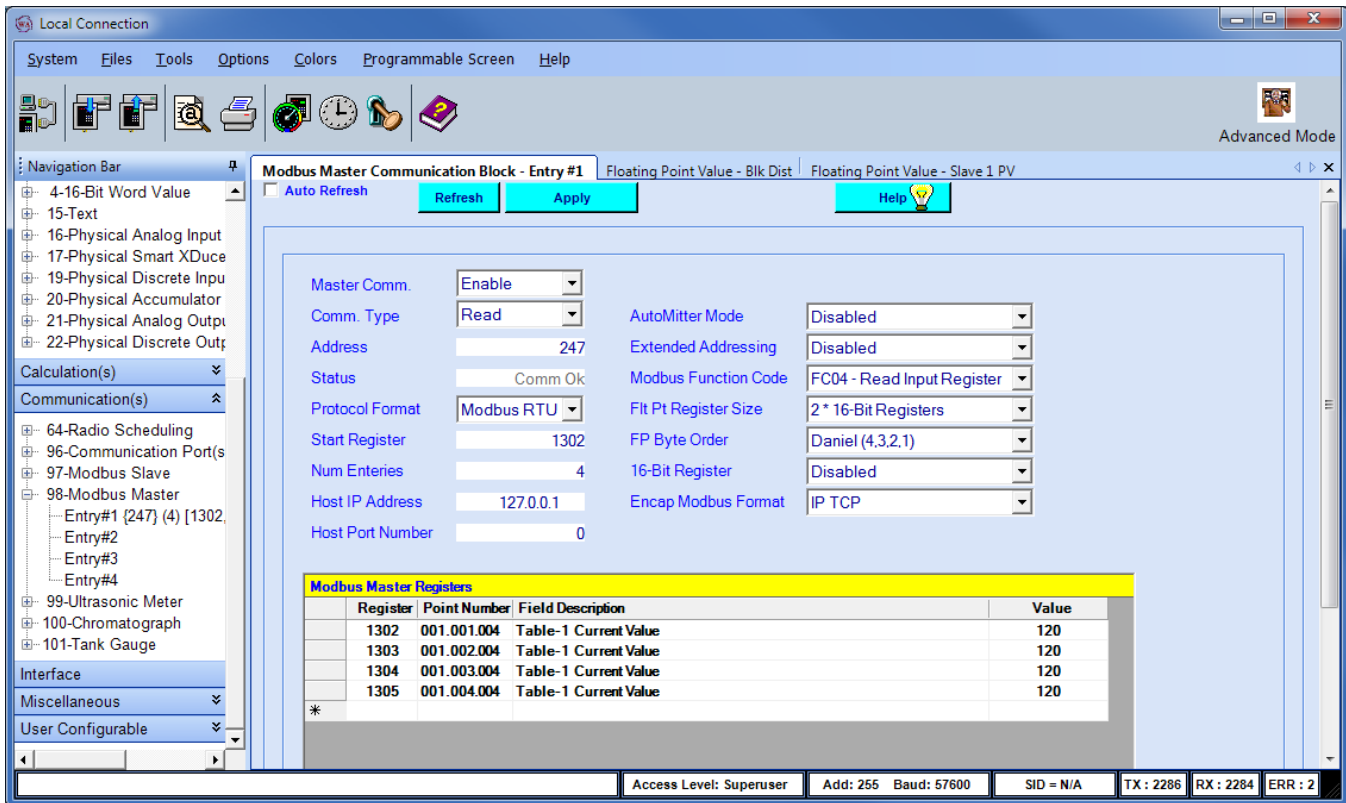

17.4.24 Right click on the Register number 1302 cell and select Paste.

17.4.25 To set up the SV, TV and QV readings, repeat steps 4.4.19 through 4.4.24 using Table 1 items 2 to 4. Paste the SV into address 1304, TV into address 1306 and QV into address 1308.

17.4.26 Click on Apply to send the settings to the AutoPILOT PRO.

17.4.27 Check on Auto Refresh to start the AutoPILOT PRO to repeatedly read the values from the device.

## 17.5. Writing registers to the HMA

17.5.1 The followings steps demonstrate how to write the Blocking Distance to a HART device attached to the HMA. When making any changes to the settings, click on Apply at the top of the window to write them to the AutoPilot Pro.

17.5.2 In the Navigation Bar, click on Communication(s), expand the 96-Communication Port(s) item, and then double-click on Host Comm Port.

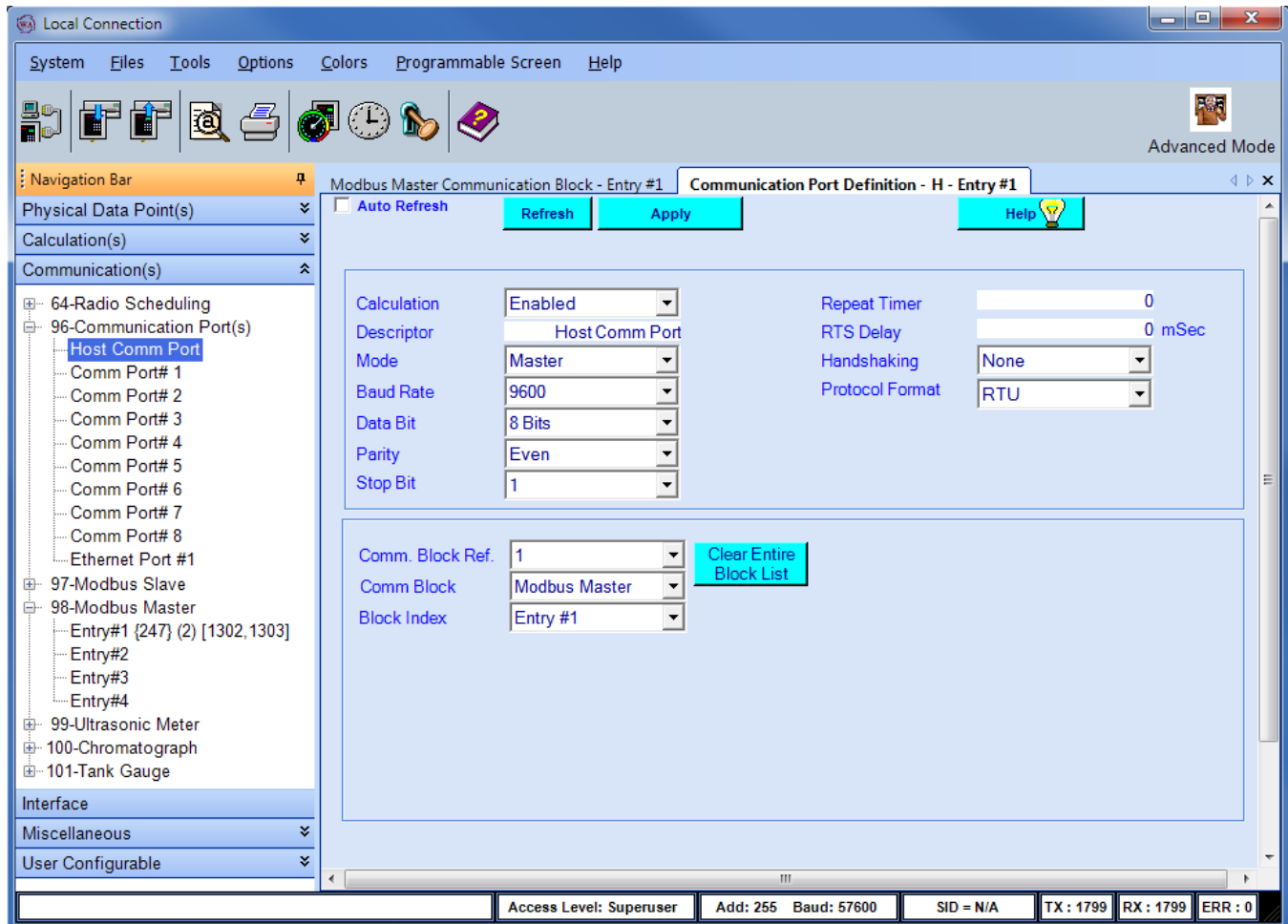

17.5.3 Set Calculation to Enabled.

17.5.4 Set the Repeat Timer to the desired sampling interval in seconds.

17.5.5 Ensure that the communication settings match the selections made in step 17.1.1.

17.5.6 Set the Comm. Block Ref to 1, the Comm Block to Modbus Master, and the Block Index to Entry #1.

17.5.7 Click on Apply to send the settings to the AutoPILOT PRO.

In the Navigation Bar, click on Communication(s), expand the 98-Modbus Master item, and then double-click on Entry#1.

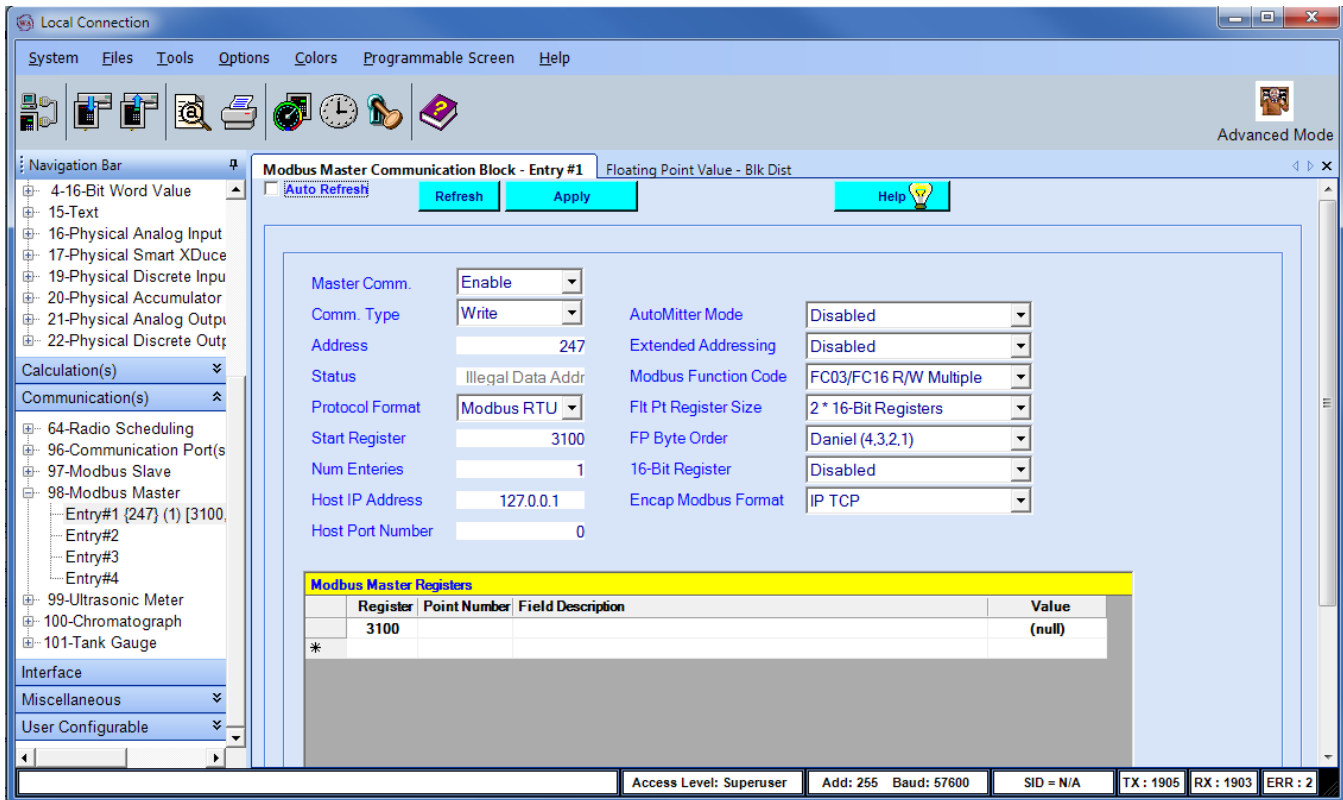

- 17.5.8 Set Master Comm. to Enable.
- 17.5.9 Set Comm. Type to Write.
- 17.5.10 Set the Address to the Modbus address of the HMA.
- 17.5.11 Set the Start Register to 3100 (the start of the Blocking Distance register for Slave 1 in the HMA).
- 17.5.12 Set the Num Entries to 1 (one 32-bit floating point number).
- 17.5.13 The Host IP Address, Host Port Number, AutoMitter Mode, Extended Addressing and Encap Modbus Format can be ignored.
- 17.5.14 Set the Modbus Function Code to FC03/FC16 R/W Multiple for reading input registers.
- 17.5.15 Set the Flt Pt Register Size to 2 \* 16-Bit Registers, and the FP Byte Order to Daniel (4,3,2,1).
- 17.5.16 Set the 16-Bit Register to Disabled.
- 17.5.17 Click on Apply to send the settings to the AutoPILOT PRO.

- 17.5.18 In the Navigation Bar, click on Physical Data Point(s), and expand the 1-Floating Point Value item.
- 17.5.19 Double click on the Table 1 Item 5 entry, and change Descriptor #1 to 'Blk Dist' and Engineering Unit to correspond to the level units in use by the HART transmitter to be read.

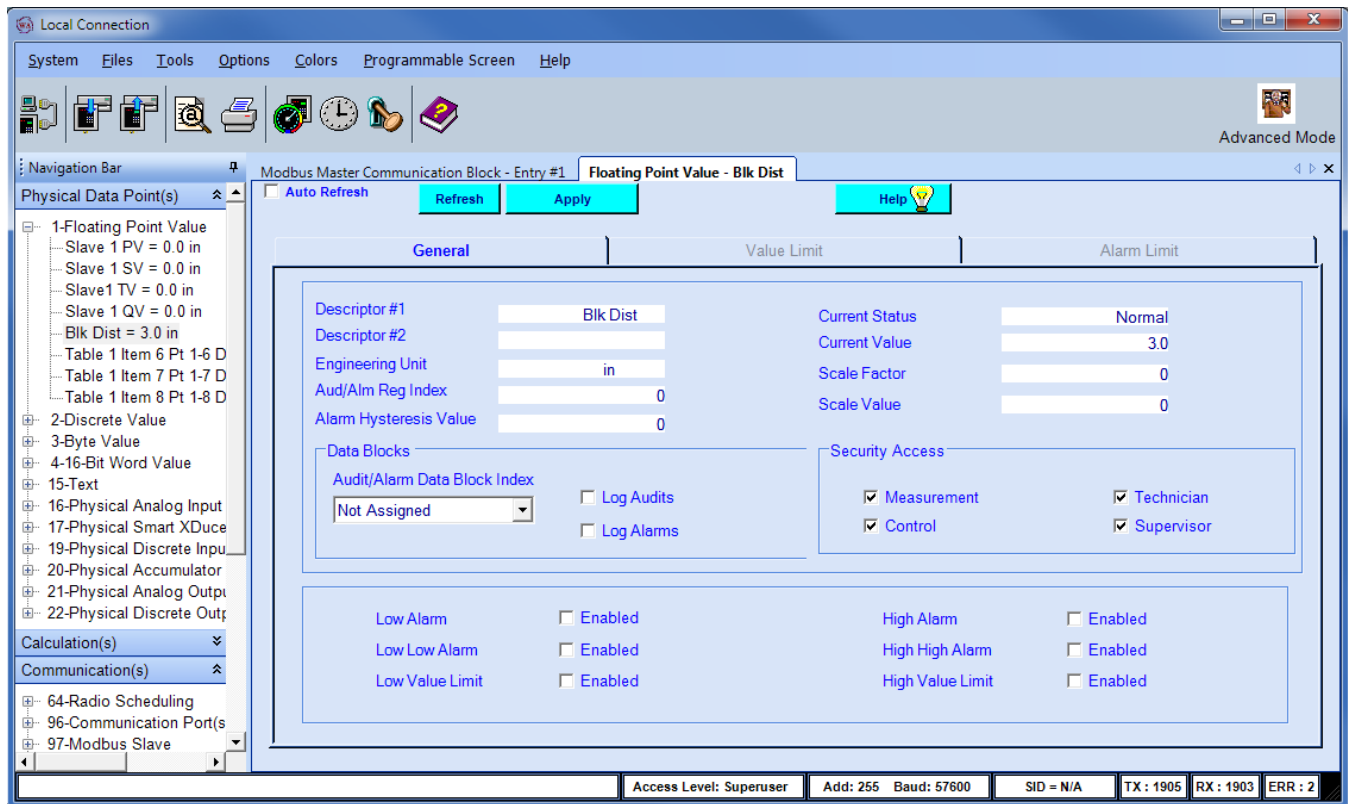

- 17.5.20 Enter the value to be sent to the device in the Current Value textbox.
- 17.5.21 Click on Apply to send the settings to the AutoPILOT PRO.
- 17.5.22 Right click on the Slave 1 Blk Dist entry in the Navigation Bar and select Copy.

17.5.23 Double click on the Entry #1 listing in the Communication(s) \ 98-Modbus Master section of the Navigation Bar.

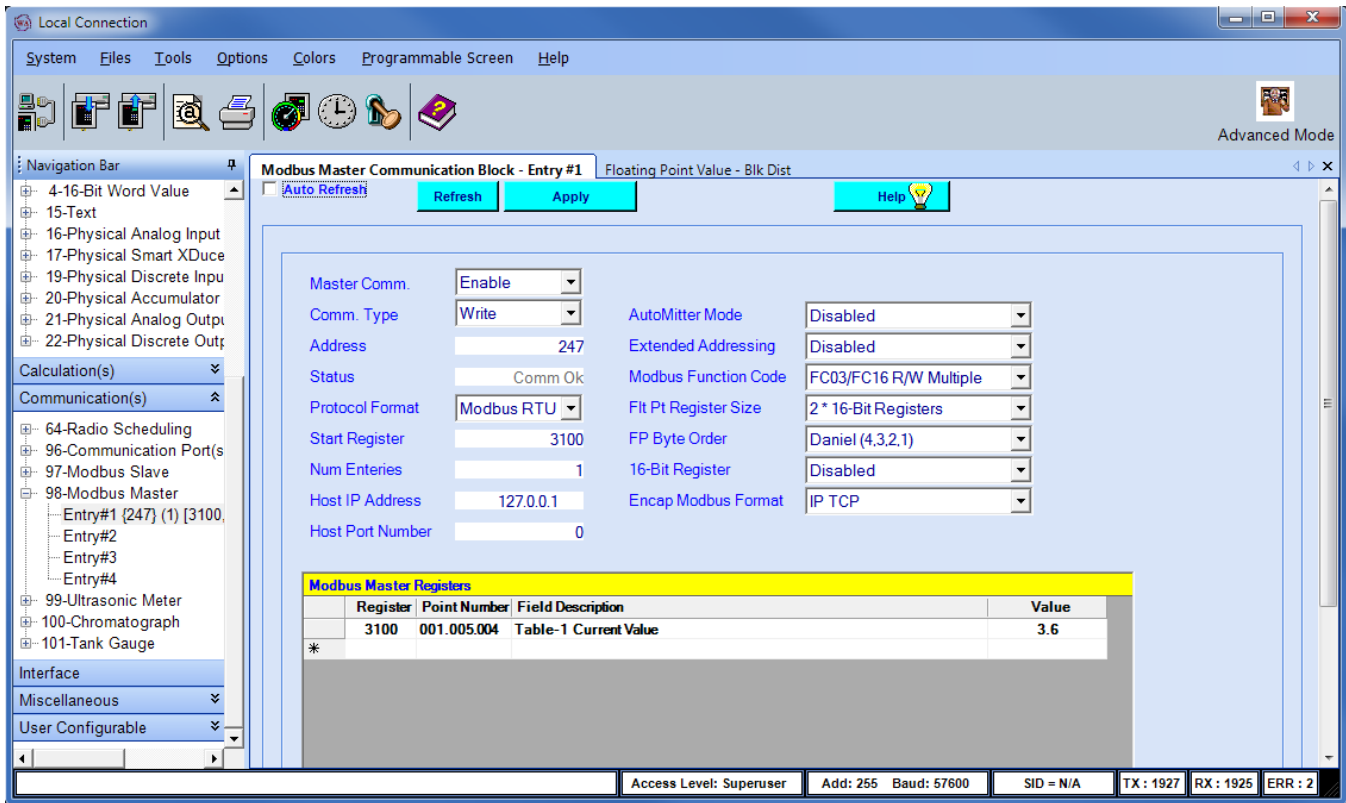

17.5.24 Right click on the Register number 3100 cell and select Paste.

17.5.25 Click on Apply to send the settings to the AutoPILOT PRO.

17.5.26 Click on Refresh to command the AutoPILOT PRO to send the value to the device.

17.5.27 Change the Comm. Type to Read.

17.5.28 Click on Apply to send the settings to the AutoPILOT PRO.

17.5.29 Click on Refresh to confirm that the device has accepted the new value.

## APPENDICES

### A. HMA Terminal Block Layout



#### Notes:

- A. For Modbus devices using 'A' and 'B' for the RS-485 connection, connect 'A' to the '-' position of the RS-485 terminal block, and 'B' to the '+' position.
- B. The RS-485 terminal block is used as the RS-232 terminal block when the positions 3 and 4 DIP switches are set to the RS-232 mode. See Appendix B.
- C. It is recommended that the wires connected to the HART terminal block be dressed such that there is some exposed wire. This will permit connecting a HART modem without breaking the HART loop in the event that additional device configuration or troubleshooting is required.

## B. HMA DIP Switch Settings

Position 1	ON	Normal mode
	OFF	Default configuration mode
Position 2	ON	Program mode
	OFF	Run mode
Position 3	OFF	RS485 mode
Position 4	ON	
Position 3	ON	RS232 mode
Position 4	OFF	

## C. HMA LED Indicators

LED D5	Green: Indicates Power ON
LED D4	Red: Indicates Error (indicated by HMA status bits)

After power on, check the LED status. If the Red LED is ON then check the HMA status by reading Modbus register 1200.



## D. HMA System Connection Diagram

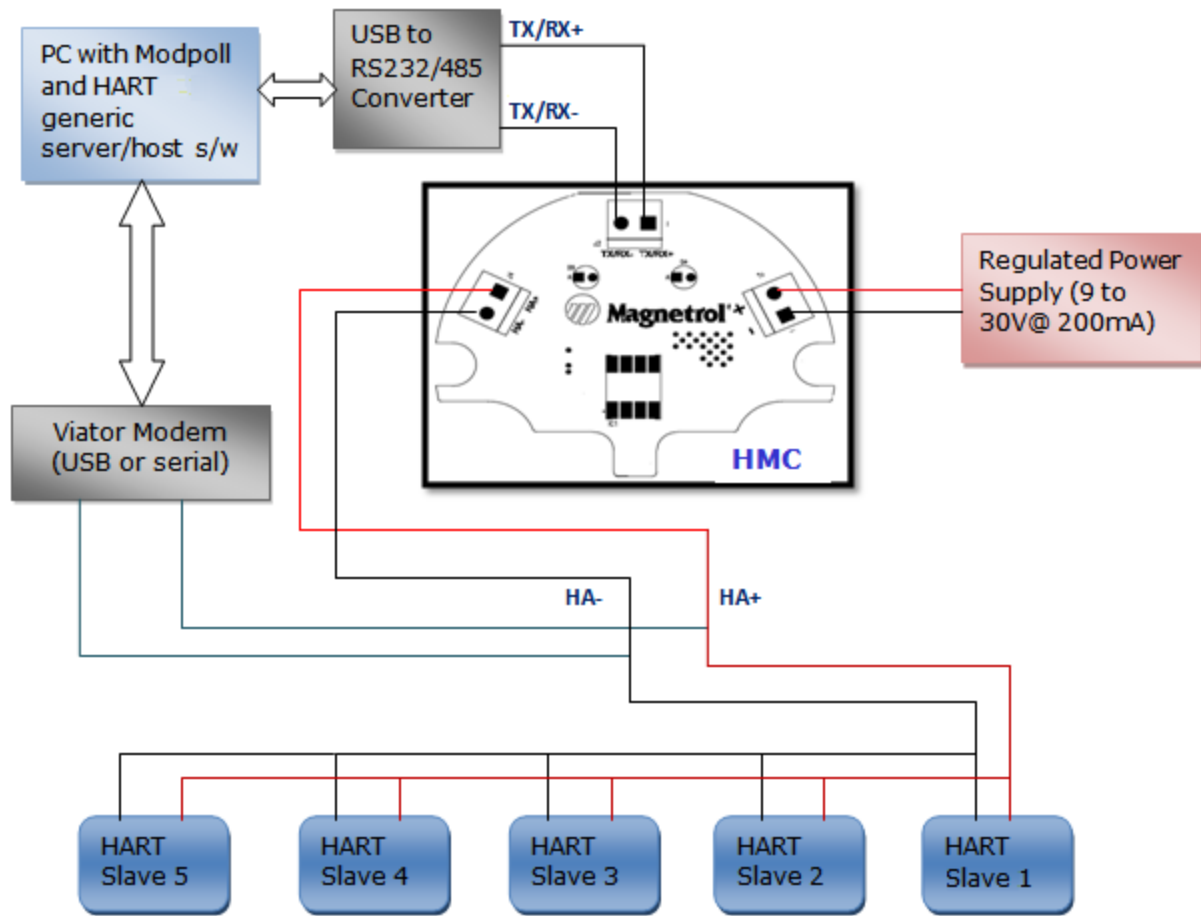

## E. Nomenclature Table

HMA Nomenclature	Modbus Poll Nomenclature
Data Type	Display
Number of Registers	Quantity
Modbus Register Type	Function
Modbus Register Number	Address

## F. HMA Communication Modbus Registers

Parameter	Data type	Number of Registers	Modbus Register type	Modbus Register number	Protocol						
					Modbus RTU		Modbus ASCII		LevelMaster		HART over RS485 Values
					Values	Default	Values	Default	Values	Default	
Floating Point Format Code	UINT8	1	Holding	3000	0 - AB CD 1 - CD AB 2 - DC BA 3 - BA DC	0	0 - ABCD 1 - CD AB 2 - DC BA 3 - BA DC	0			
Slave address	UINT8	1	Holding	3001	1 to 247	247	1 to 247	247	1 to 99	1	
Protocol Type	UINT8	1	Holding	3002	1	1	1	2	3	3	4
No of Data bits	UINT8	1	Holding	3003	7 - 7 bits 8 - 8 bits	8	7 - 7 bits 8 - 8 bits	7	7 - 7 bits 8 - 8 bits	8	8
Stop bits	UINT8	1	Holding	3004	1 - 1 bit 2 - 2 bits	1	1 - 1 bit 2 - 2 bits	1	1 - 1 bit 2 - 2 bits	1	1
Parity	UINT8	1	Holding	3005	0 - None 1 - Odd 2 - Even	0	0 - None 1 - Odd 2 - Even	0	0 - None 1 - Odd 2 - Even	0	1
Baud rate	UINT8	1	Holding	3006	0 - 1200 1 - 2400 2 - 4800 3 - 9600 4 - 19200	3	0 - 1200 1 - 2400 2 - 4800 3 - 9600 4 - 19200	3	0 - 1200 1 - 2400 2 - 4800 3 - 9600 4 - 19200	3	0
HMA Mode	UINT8	1	Holding	3007	0 - HMC 1 - Device	0	0 - HMC 1 - Device	0	0 - HMC 1 - Device	1	1
Auto-switch to HART over RS-485	UINT8	1	Holding	3008	0 - no switch 1 - switch	0	0 - no switch 1 - switch	0	0 - no switch 1 - switch	0	1
Reserved/Unused											
No of retries (General)	UINT8	1	Holding	3010	0, 1, 2, 3		0, 1, 2, 3				
Reserved/Unused											
Device Discovery mode (DDM)	UINT8	1	Holding	3012	0 - Polled 1 - Saved 2 - Single		0 - Polled 1 - Saved 2 - Single				
Polling Range (if DDM = 0, 2)	UINT8	1	Holding	3013	0 - 0 only 1 - Find first only 2 - search 0-15 3 - search 0-31 4 - search 0-63		0 - 0 only 1 - Find first only 2 - search 0-15 3 - search 0-31 4 - search 0-63				

## G. HMA Diagnostics Modbus Registers

Parameter	Modbus Register Info			Modbus Register	
	Data type	Number	Type	Number	Bit
Configuration data error	UINT8	1	Input	1200	0
No HART communications					1
Communication Mode (0 == RS232, 1 == RS485)					2
EEPROM failure					3
HMA Ready					4
Reserved/Unused					5
Reserved/Unused					6
Configured & connected Slaves mismatch (mismatch in number or mismatch in device identification)					7
Reserved/Unused					8
Buckboost Fail					9
Slave 1 malfunction (Comm error)					10
Slave 2 malfunction (Comm error)					11
Slave 3 malfunction (Comm error)					12
Slave 4 malfunction (Comm error)					13
Slave 5 malfunction (Comm error)					14
Configuration data area checksum error	15				
Byte 3 bits - Reserved	UINT8	1	Input	1201	
Byte 4 bits - Reserved	UINT8	1	Input		
HMA Firmware Version	UINT8	8	Input	1205	
HMA Serial Number	UINT8	6	Input	1213	
Number of attached devices	UINT8	1	Input	1250	
Slave 1 Device Type	UINT8	1	Input	1251	
Slave 2 Device Type	UINT8	1	Input	1252	
Slave 3 Device Type	UINT8	1	Input	1253	
Slave 4 Device Type	UINT8	1	Input	1254	
Slave 5 Device Type	UINT8	1	Input	1255	
Slave 1 Poll Address	UINT8	1	Input	1256	
Slave 2 Poll Address	UINT8	1	Input	1257	
Slave 3 Poll Address	UINT8	1	Input	1258	
Slave 4 Poll Address	UINT8	1	Input	1259	
Slave 5 Poll Address	UINT8	1	Input	1260	

## H. HMA Device Information Modbus Registers

Parameter	Modbus Register Info			Modbus Register Number					
	Data type	Number	Type	Device Mode	HMA Mode				
					Slave 1	Slave 2	Slave 3	Slave 4	Slave 5
Polling Address	UINT8	1	Input	1000	1000	1020	1040	1060	1080
Loop Current Mode	UINT8	1	Input	1001	1001	1021	1041	1061	1081
Device Type	UINT16	2	Input	1002	1002	1022	1042	1062	1082
Min Preambles in request	UINT8	1	Input	1003	1003	1023	1043	1063	1083
Protocol Rev	UINT8	1	Input	1004	1004	1024	1044	1064	1084
Device rev	UINT8	1	Input	1005	1005	1025	1045	1065	1085
S/w rev	UINT8	1	Input	1006	1006	1026	1046	1066	1086
H/W rev/physical sign code	UINT8	1	Input	1007	1007	1027	1047	1067	1087
Flags	UINT8	1	Input	1008	1008	1028	1048	1068	1088
Device ID	UINT8	4	Input	1009	1009	1029	1049	1069	1089
Minimum Preambles in response	UINT8	1	Input	1011	1011	1031	1051	1071	1091
Max Device Variables	UINT8	1	Input	1012	1012	1032	1052	1072	1092
Reserved/Unused									
Extended field device status	UINT8	1	Input	1014	1014	1034	1054	1074	1094
Manufacturer code	UINT8	1	Input	1015	1015	1035	1055	1075	1095
Pvt Label Distributor code	UINT8	1	Input	1016	1016	1036	1056	1076	1096
Device Profile	UINT8	1	Input	1017	1017	1037	1057	1077	1097

## I. Model 706, Model JM4 Modbus Registers

HART parameter	Modbus Register Info			Modbus Register Number					
	Data Type	Number	Type	Device Mode	HMA Mode				
					Slave 1	Slave 2	Slave 3	Slave 4	Slave 5
PV value	Float	2	Input	1302	1302	1312	1322	1332	1342
SV value	Float	2	Input	1304	1304	1314	1324	1334	1344
TV value	Float	2	Input	1306	1306	1316	1326	1336	1346
QV value	Float	2	Input	1308	1308	1318	1328	1338	1348
PV units code	UINT8	1	Input	104	104	124	144	164	184
SV units code	UINT8	1	Input	108	108	128	148	168	188
TV units code	UINT8	1	Input	112	112	132	152	172	192
QV units code	UINT8	1	Input	116	116	136	156	176	196
Command 48 status bytes	UINT8	5	Input	1101-1105	1101-1105	1111-1115	1121-1125	1131-1135	1141-1145
Serial Number	UINT8	6	Input	2100	2100	2200	2300	2400	2500
Software version	UINT8	8	Input	2112	2112	2212	2312	2412	2512
Reserved/Unused									
Blocking Distance	Float	2	Holding	3100	3100	3200	3300	3400	3500
Level Unit <a href="#">code</a>	UINT8	1	Input	2140	2140	2240	2340	2440	2540
Level Offset	Float	2	Holding	3102	3102	3202	3302	3402	3502
Level Unit code	UINT8	1	Input	2141	2141	2241	2341	2441	2541
Advanced Password	UINT32	2	Input	2156	2156	2256	2356	2456	2556
Reserved/Unused									
HART entered password	UINT16	2	Holding	3110	3110	3210	3310	3410	3510
Reserved/Unused									
Device variable assigned to <a href="#">SV</a>	UINT8	1	Holding	3130	3130	3230	3330	3430	3530
Sensitivity	UINT8	1	Holding	3131	3131	3231	3331	3431	3531
Level Threshold <a href="#">code</a>	UINT8	1	Holding	3132	3132	3232	3332	3432	3532
Interface Level Threshold <a href="#">code</a>	UINT8	1	Holding	3133	3133	3233	3333	3433	3533
Level Threshold Amplitude	UINT8	1	Holding	3134	3134	3234	3334	3434	3534
Interface Threshold Amplitude	UINT8	1	Holding	3135	3135	3235	3335	3435	3535

## J. Model 705 3x Modbus Registers

HART parameter	Modbus Register Info			Modbus Register Number					
	Data Type	Number	Type	Device Mode	HMA Mode				
					Slave 1	Slave 2	Slave 3	Slave 4	Slave 5
PV value	Float	2	Input	1302	1302	1312	1322	1332	1342
SV value	Float	2	Input	1304	1304	1314	1324	1334	1344
TV value	Float	2	Input	1306	1306	1316	1326	1336	1346
QV value	Float	2	Input	1308	1308	1318	1328	1338	1348
PV units code	UINT8	1	Input	104	104	124	144	164	184
SV units code	UINT8	1	Input	108	108	128	148	168	188
TV units code	UINT8	1	Input	112	112	132	152	172	192
QV units code	UINT8	1	Input	116	116	136	156	176	196
Command 48 status bytes	UINT8	4	Input	1101-1104	1101-1104	1111-1114	1121-1124	1131-1134	1141-1144
Serial Number	UINT8	6	Input	2100	2100	2200	2300	2400	2500
Software version	UINT8	4	Input	2112	2112	2212	2312	2412	2512
<b>Reserved/Unused</b>									
Blocking Distance	Float	2	Holding	3100	3100	3200	3300	3400	3500
Level Unit <a href="#">code</a>	UINT8	1	Input	2140	2140	2240	2340	2440	2540
Level Offset	Float	2	Holding	3102	3102	3202	3302	3402	3502
Level Unit code	UINT8	1	Input	2141	2141	2241	2341	2441	2541
<b>Reserved/Unused</b>									
User Password	UINT16	1	Holding	3120	3120	3220	3320	3420	3520
<b>Reserved/Unused</b>									
Device variable assigned to <a href="#">SV</a>	UINT8	1	Holding	3130	3130	3230	3330	3430	3530
Sensitivity	UINT8	1	Holding	3131	3131	3231	3331	3431	3531
Negative Threshold <a href="#">code</a>	UINT8	1	Holding	3132	3132	3232	3332	3432	3532
Negative Threshold Amplitude	UINT8	1	Holding	3133	3133	3233	3333	3433	3533
Interface Lvl Thresh <a href="#">code</a>	UINT8	1	Holding	3134	3134	3234	3334	3434	3534
Interface Lvl Thresh Amplitude	UINT8	1	Holding	3135	3135	3235	3335	3435	3535

## K. Model R82 R2 Modbus Registers

HART parameter	Modbus Register Info			Modbus Register Number					
	Data Type	Number	Type	Device Mode	HMA Mode				
					Slave 1	Slave 2	Slave 3	Slave 4	Slave 5
PV value				1302	1302	1312	1322	1332	1342
SV value	Float	2	Input	1304	1304	1314	1324	1334	1344
TV value	Float	2	Input	1306	1306	1316	1326	1336	1346
QV value	Float	2	Input	1308	1308	1318	1328	1338	1348
PV units code	UINT8	1	Input	104	104	124	144	164	184
SV units code	UINT8	1	Input	108	108	128	148	168	188
TV units code	UINT8	1	Input	112	112	132	152	172	192
QV units code	UINT8	1	Input	116	116	136	156	176	196
Command 48 status bytes	UINT8	2	Input	1101-1102	1101-1102	1111-1112	1121-1122	1131-1132	1141-1142
Serial Number	UINT8	6	Input	2100	2100	2200	2300	2400	2500
Software version	UINT8	6	Input	2112	2112	2212	2312	2412	2512
Reserved/Unused									
Blocking Distance	Float	2	Holding	3100	3100	3200	3300	3400	3500
Level Unit <a href="#">code</a>	UINT8	1	Input	2140	2140	2240	2340	2440	2540
Level Offset	Float	2	Holding	3102	3102	3202	3302	3402	3502
Level Unit code	UINT8	1	Input	2141	2141	2241	2341	2441	2541
Reference Distance	Float	2	Holding	3104	3104	3204	3304	3404	3504
Level Unit code	UINT8	1	Input	2142	2142	2242	2342	2442	2542
Reserved/Unused									
Password	UINT16	1	Holding	3120	3120	3220	3320	3420	3520
TVG Min	UINT16	1	Holding	3122	3122	3230	3330	3430	3530
Reserved/Unused									
Device variable assigned to <a href="#">SV</a>	UINT8	1	Holding	3130	3130	3230	3330	3430	3530
Dielectric Range <a href="#">code</a>	UINT8	1	Holding	3131	3131	3231	3331	3431	3531
Turbulence <a href="#">code</a>	UINT8	1	Holding	3132	3132	3232	3332	3432	3532
Rate of Change <a href="#">code</a>	UINT8	1	Holding	3133	3133	3233	3333	3433	3533
Foam <a href="#">code</a>	UINT8	1	Holding	3134	3134	3234	3334	3434	3534

## L. Model RX5 Modbus Registers

HART parameter	Modbus Register Info			Modbus Register Number					
	Data Type	Number	Type	Device Mode	HMA Mode				
					Slave 1	Slave 2	Slave 3	Slave 4	Slave 5
PV value				1302	1302	1312	1322	1332	1342
PV units code	UINT8	1	Input	104	104	124	144	164	184
Command 48 status bytes	UINT8	1	Input	1101	1101	1111	1121	1131	1141
Serial Number	UINT8	6	Input	2100	2100	2200	2300	2400	2500
Software version	UINT8	6	Input	2112	2112	2212	2312	2412	2512
Reserved/Unused									
Blocking Distance	Float	2	Holding	3100	3100	3200	3300	3400	3500
Level Unit <a href="#">code</a>	UINT8	1	Input	2140	2140	2240	2340	2440	2540
Level Offset	Float	2	Holding	3102	3102	3202	3302	3402	3502
Level Unit code	UINT8	1	Input	2141	2141	2241	2341	2441	2541
Distance	Float	2	Input	2150	2150	2250	2350	2450	2550
Echo Strength	Float	2	Input	2153	2153	2253	2353	2453	2553
Reserved/Unused									
Password	UINT16	1	Holding	3120	3120	3220	3320	3420	3520
Reserved/Unused									
Dielectric Range <a href="#">code</a>	UINT8	1	Holding	3130	3130	3230	3330	3430	3530
Turbulence <a href="#">code</a>	UINT8	1	Holding	3131	3131	3231	3331	3431	3531
Rate of Change <a href="#">code</a>	UINT8	1	Holding	3132	3132	3232	3332	3432	3532
Foam <a href="#">code</a>	UINT8	1	Holding	3133	3133	3233	3333	3433	3533



## M. Model 355 Modbus Registers

HART parameter	Modbus Register Info			Modbus Register Number					
	Data Type	Number	Type	Device Mode	HMA Mode				
					Slave 1	Slave 2	Slave 3	Slave 4	Slave 5
PV value	Float	2	Input	1302	1302	1312	1322	1332	1342
SV value	Float	2	Input	1304	1304	1314	1324	1334	1344
TV value	Float	2	Input	1306	1306	1316	1326	1336	1346
QV value	Float	2	Input	1308	1308	1318	1328	1338	1348
PV units code	UINT8	1	Input	104	104	124	144	164	184
SV units code	UINT8	1	Input	108	108	128	148	168	188
TV units code	UINT8	1	Input	112	112	132	152	172	192
QV units code	UINT8	1	Input	116	116	136	156	176	196
Command 48 status bytes	UINT8	2	Input	1101-1102	1101-1102	1111-1112	1121-1122	1131-1132	1141-1142
Serial Number	UINT8	6	Input	2100	2100	2200	2300	2400	2500
Software version	UINT8	6	Input	2112	2112	2212	2312	2412	2512
Reserved/Unused									
Blocking Distance	Float	2	Holding	3100	3100	3200	3300	3400	3500
Level Unit <a href="#">code</a>	UINT8	1	Input	2140	2140	2240	2340	2440	2540
Level Offset	Float	2	Holding	3102	3102	3202	3302	3402	3502
Level Unit code	UINT8	1	Input	2141	2141	2241	2341	2441	2541
Range	Float	2	Holding	3104	3104	3204	3304	3404	3504
Level Unit code	UINT8	1	Input	2142	2142	2242	2342	2442	2542
Damping Value	Float	2	Holding	3106	3106	3206	3306	3406	3506
Reference Distance	Float	2	Holding	3108	3108	3208	3308	3408	3508
Level Unit code	UINT8	1	Input	2144	2144	2244	2344	2444	2544
Reserved/Unused									
Password	UINT16	1	Holding	3120	3120	3220	3320	3420	3520
Reserved/Unused									
Device variable assigned to <a href="#">SV</a>	UINT8	1	Holding	3130	3130	3230	3330	3430	3530
Peak Threshold	UINT8	1	Holding	3131	3131	3231	3331	3431	3531
TVG	UINT8	1	Holding	3132	3132	3232	3332	3432	3532
Reserved/Unused									
Echo Strength	UINT8	1	Input	2160	2160	2260	2360	2460	2560

## N. Enhanced Jupiter Modbus Registers

HART parameter	Modbus Register Info			Modbus Register number					
	Data type	Number	Type		Slave	Slave	Slave	Slave	Slave
					1	2	3	4	5
PV value	Float	2	Input	1302	1302	1312	1322	1332	1342
SV value	Float	2	Input	1304	1304	1314	1324	1334	1344
PV units code	UINT8	1	Input	104	104	124	144	164	184
SV units code	UINT8	1	Input	108	108	128	148	168	188
Command 48 status bytes	UINT8	1	Input	1101	1101	1111-	1121	1131-	1141
Serial Number	UINT8	6	Input	2100	2100	2200	2300	2400	2500
Software version	UINT8	4	Input	2112	2112	2212	2312	2412	2512
Reserved/Unused									
Trim Level	Float	2	Holding	3100	3100	3200	3300	3400	3500
Level Unit <a href="#">code</a>	UINT8	1	Input	2140	2140	2240	2340	2440	2540
Trim Ifc Level	Float	2	Holding	3102	3102	3202	3302	3402	3502
Level Unit code	UINT8	1	Input	2141	2141	2241	2341	2441	2541
Reserved/Unused									
Password	UINT16	1	Holding	3120	3120	3220	3320	3420	3520
Reserved/Unused									
Device variable assigned to <a href="#">SV</a>	UINT8	1	Holding	3130	3130	3230	3330	3430	3530

## O. E3 Modulelevel Modbus Registers

HART parameter	Modbus Register Info			Modbus Register number					
	Data type	Number	Type	Device Mode	HMA Mode				
					Slave 1	Slave 2	Slave 3	Slave 4	Slave 5
PV value	Float	2	Input	1302	1302	1312	1322	1332	1342
PV units code	UINT8	1	Input	104	104	124	144	164	184
Command 48 status bytes	UINT8	4	Input	1101-1104	1101-1104	1111-1114	1121-1124	1131-1134	1141-1144
Serial Number	UINT8	6	Input	2100	2100	2200	2300	2400	2500
Software version	UINT8	4	Input	2112	2112	2212	2312	2412	2512
Reserved/Unused									
Trim Level	Float	2	Holding	3100	3100	3200	3300	3400	3500
Level Unit <a href="#">Code</a>	UINT16	1	Input	2140	2140	2240	2340	2440	2540
Process SG	Float	2	Holding	3102	3102	3202	3302	3402	3502
Trim SG	Float	2	Holding	3104	3104	3204	3304	3404	3504
Reserved/Unused									
Password	UINT16	1	Holding	3120	3120	3220	3320	3420	3520
Operating Temperature	UINT16	1	Holding	3122	3122	3222	3322	3422	3522
Temperature units code	UINT8	1	Input	2160	2160	2260	2360	2460	2560

## P. LevelMaster Error and Warning Codes

Error Code	Model 705 3x R2	Model R82	Model 355	Enhanced Jupiter	E3 Madulevel	Model RX5
1	Software Fault	Dflt Parm Fact	Dflt Parm Sys	Snsr Brd Failed	Fault	Default Params
2	ADC Failure	Dflt Parm Sys	Dflt Parm Adv	No Signal	Fault 2	No Fiducial
3	EEPROM Error	Dflt Parm Adv	Dflt Parm I/O	Float 1 Fail	Secondary Fault Lo	Echo Lost
4	Default Params	Dflt Parm I/O	Dflt Parm Fact	Default Params	Default Params	Safety Zone Alarm
5	No Ramp	Dflt Parm HART	Dflt Parm HART	Loop Failure	Loop Failure	CPU Failure
6	Loop Fail	Dflt Strap Tbl	Dflt Strap Tbl	Float 2 Fail	Secondary Fault Hi	EE Read Failure
7	Fid Shift	Dflt Parm Total	Dflt Parm Total	Fault 2	Primary Fault	EE Write Failure
8	Ramp Slope	Cnfg Conflict	Cnfg Conflict	Fault1	Core Drop	Software Erro
9	Lvl Below Probe End	RF Brd Failure	Hardware Failure			
10	No Probe	Loop Failure	Hardware Failure			
11	No Fiducial	Fault 2	Temperature Failure			
12	Safety Zone Alarm	Safe Zone Alrm	Blocking Distance			
13	No Signal	Echo Lost	Hi Volume Alrm			
14	EoP < Probe End	High Flow Alrm	High Flow Alrm			
15	EoP > Probe End	Hi Volume Alrm	Safe Zone Alarm			
16	High Vol Alarm	Fault 1	Echo Lost			
<b>Warning Code</b>						
1	Warning 1	Initializing	Warning 1	Warning 2	Warning 1	Factory Cal Req'd
2	Seal Leak	Warning 4	Low VDC at 20 mA	Warning 1	Cal Span Warning	Fiducial Unclear
3	Fid Spread	LowVDC@20mA	Noise	Hi Temperature	Calib Req'd	Corrupt Targ Rej
4	Warning 2	Warning 3	High Elec Temp	Low Temperature	Hi Temperature	No False Targ Rej
5	High Elec Temp	No Echo Rej	Low Elec Temp	System Warning	Lo Temperature	Button Failure
6	Low Elec Temp	Echo Rej Crpt	Echo Rej Crpt	Trim Req'd	Trim Req'd	Warning 04
7	Cal Req'd	Echo Rej Invl	Echo Rej Invl	Initializing	Intilaizing	Warning 02
8	EoP Low	Echo Rej Disable	Initializing	Calib Req'd	Warning 2	Warning 01
9	Trim Req'd	Echo Rej Insf	System Code			
10	No Target	Warning 2				
11	Warning 4	High Elec Temp				
12	Initializing	Low Elec Temp				
13	May Be Flooded	Rate Of Change				
14	Dry Probe	Warning 1				
15	Weak Signal	System Code				
16	System Warning					

<b>Error Code</b>	<b>Model 706</b>	<b>Model JM4</b>
1	Software Error	SW Error (Main)
2	RAM Error	RAM Error (Main)
3	ADC Failure	ADC Error (Main)
4	EEPROM Error	EEPROM Error
5	Analog Board Error	CoP in Flash Mode
6	Analog Output Error	SW Conflict (CoP)
7	Spare 1	Spare 1
8	Default Parameters	Analog Board Error
9	No Probe	SW Error (CoP)
10	No Fiducial	RAM Error (CoP)
11	No Echoes	ADC Error (CoP)
12	Upper Echo Lost	Spare 2
13	Spare 2	Analog Output Error
14	EoP > Probe End	No Probe
15	Level Below Probe End	Probe Memory Error
16	EoP Below Probe End	Probe Info Corrupt
17	Safety Zone Alarm	Spare 3
18	Config Conflict	New Probe
19	Hi Volume Alarm	Default Parameters
20	Hi Flow Alarm	No Float Detected
21	Spare 3	Spare 4
22	Initializing	Config Conflict
23	Analog Output Fixed	Hi Volume Alarm
24	Config Changed	Spare 5
25	Spare 4	Extra Float Detected
26	Spare 5	2nd Float Missing
27	Spare 6	Initializing
28	Ramp Interval Error	Config Changed
29	Hi Elec Temp	Spare 6
30	Lo Elec Temp	Xmtr Calib Req'd
31	Calib Req'd	Spare 7
32	Echo Rej Invalid	Temp Calib Req'd
33	Spare 7	Hi Elec Temp
34	Inferred Level	Lo Elec Temp
35	Adj Analog Output	Spare 8
36	Totalizer Data Lost	Spare 9
37	No Probe Target	Adj Analog Output
38	Low Supply Voltage	Low Supply Voltage
39	Dry Probe	Spare 10
40	Spare 8	Lo Echo Strength
41	Lo Echo Strength	Lo Ifc Echo Strength
42	Lo Ifc Echo Strength	Hi Noise / LvlThresh
43	Spare 9	Hi Noise / IfcThresh
44	Spare 10	Spare 10
45	Sequence Record	Sequence Record

### Q. Level Unit Codes

<b>Code</b>	44	45	47	48	49
<b>Unit</b>	feet	meters	inches	centimeters	millimeters

### R. Parameter Codes

SV Code	Model 706	Model JM4	Model 705 3x R2	Model R82 R2	Model 355	E3 Modulelevel
0	Level	Level	Level	Level	Level	Level
1	Ifc Level	Ifc Level	Volume	Volume	Flow	Ifc Level
2	Ifc Thickness	Ifc Thickness	Ifc Level	Distance	Volume	Density
3	Volume	Volume	Ifc Volume	Echo Strength	Head	
4	Flow	Fill Rate		Flow	Distance	
5	Distance	Distance		Head	Totalizer R	
6	Echo Strength	Echo Strength		Totalizer R	Totalizer NR	
7	Head	Elec Temp		Totalizer NR	Process Temp	
8	Totalizer R	Ifc Echo Strength			Custom Unit	
9	Totalizer NR					
10	Elec Temp					
11	Ifc Echo Strength					
12	Probe Buildup					

SV Code	Enhanced Jupiter					
0	Level					
1	Ifc Level					
2						
3						
4						
5						
6						
7						
8						
9						
10						
11						
12						

<b>Threshold Code</b>	<b>Model 706</b>	<b>Model JM4</b>	<b>Model 705 3x R2</b>			
0	Auto Largest	Auto Largest	Fixed			
1	Fixed	Fixed	CFD			
2	Auto Upper	Sloped				
3	Sloped					

<b>Dielectric Range Code</b>	<b>Model R82 R2</b>	<b>Model RX5</b>				
0	1.7 - 3	1.7 - 3				
1	3 - 10	3 - 10				
2	10 - 100	10 - 100				

<b>Turbulence Code</b>	<b>Model R82 R2</b>	<b>Model RX5</b>				
0	None	None				
1	Light	Light				
2	Medium	Medium				
3	Heavy	Heavy				

<b>Rate of Change Code</b>	<b>Model R82 R2</b>	<b>Model RX5</b>				
0	< 5 in/min	< 5 in/min				
1	5 - 20 in/min	5 - 20 in/min				
2	20 - 60 in/min	20 - 60 in/min				
3	> 60 in/min	> 60 in/min				

<b>Foam Code</b>	<b>Model R82 R2</b>	<b>Model RX5</b>				
0	None	None				
1	Light	Light				
2	Medium	Medium				
3	Heavy	Heavy				

---

## About Modbus

### Our Mission

The Modbus Organization is a group of independent users and suppliers of automation devices that seeks to drive the adoption of the Modbus communication protocol suite and the evolution to address architectures for distributed automation systems across multiple market segments. The Modbus Organization will also provide the infrastructure to obtain and share information about the protocols, their application and certification to simplify implementation by users resulting in reduced costs.

### Organization

The Modbus Organization is a membership-based trade association, incorporated as "Modbus Organization, Inc." under the laws of the Commonwealth of Massachusetts, USA and recognized by the U.S. Internal Revenue Service as a nonprofit organization under Internal Revenue Code 501(c)(6). Donations to the organization are not deductible as charitable contributions but may be deductible as a business expense. The Modbus Organization's annual IRS Form 990 is available upon request via our contact page, providing the complete name, address, and e-mail address of the requesting organization or individual.



### Our Member Logo

Our membership logo symbolizes a round table, meaning that we invite all our members to participate in the technical and educational activities of our organization. Suppliers large and small, system integrators, end users, open source developers, educators and other interested parties are all invited to join in the discussions that will take the Modbus protocol into the future.

### Our Activities

The Modbus Organization engages in a broad range of activities relating to the maintenance and proliferation of the Modbus protocol. Some of these activities include:

- Participation in standards activities worldwide.
- Leading the evolution of the Modbus protocol and its variants.
- Encouraging and assisting the use of Modbus across a broad spectrum of physical layers and transmission media.
- Maintaining and evolving a conformance testing program to insure greater interoperability of Modbus devices.
- Providing information to users and suppliers alike to help them be successful in their use of Modbus.
- Engaging in educational and promotional efforts including trade shows, newsletters, this website, and other outreach activities.

### Our Invitation

Our invitation is to you, as a Modbus user or supplier, to join in our activities, share in the benefits of Modbus Organization membership, and help us bring Modbus into the future. We are committed to maintaining Modbus as the world's leading protocol for industrial automation, and invite you to take your place at our roundtable.

For more information about Modbus Organization membership, please see our Membership Flyer and Membership Application. Refer to our contact page (<http://modbus.org/contact.php>) for ways to get in touch - we'd be glad to hear from you!



705 Enterprise Street • Aurora, Illinois 60504-8149 • 630-969-4000 • Fax 630-969-9489  
info@magnetrol.com • www.magnetrol.com

BULLETIN: 41-621.0  
EFFECTIVE: March 2015