

ECLIPSE® 706GWR

Eclipse® Model 706
FOUNDATION fieldbus™
Operating Manual
Software Version 1.x

*High Performance, 4th Generation
Guided Wave Radar
Level Transmitter*



Use in conjunction with I&O manual BE 57-606



Eclipse® Model 706 GWR transmitter with FOUNDATION Fieldbus™ Output

Table of Contents

1.0 FOUNDATION fieldbus™	4	4.0 Model 706 Transmitter Configuration	32
1.1 Overview	4	4.1 Configuration Information	32
1.2 Device Description (DD)	5	4.2 Menu Transversal and Data Entry	33
1.2.1 FOUNDATION fieldbus™ DD Revision Table	5	4.2.1 Navigating the Menu	33
1.3 Link Active Scheduler (LAS)	5	4.2.2 Data Selection	33
1.4 Intrinsic Safety	6	4.2.3 Entering Numeric Data Using Digit Entry	34
2.0 Standard Function Blocks	7	4.2.4 Entering Numerica Data Using Increment/Decrement	34
2.1 Overview	7	4.2.5 Enter Character Data	35
2.1.1 Universal Fieldbus Block Parameters	8	4.3 Password Protection	36
2.2 Resource Block (RB)	9	4.4 Model 706 Menu: Step-By-Step Procedure	36
2.2.1 RB Parameters	9	4.5 Model 706 Configuration Menu: Device Setup	38
2.2.2 Additional Resource Block Parameters	11	5.0 Troubleshooting and Diagnostics	44
2.3 Transducer (TB)	13	5.1 Diagnostic Parameters	44
2.3.1 TB Parameters	14	5.1.1 Diagnostics (Namur NE 107)	45
2.3.2 Password Protection	14	5.1.2 Diagnostic Indication Simulation	47
2.3.3 Model 706 FF Configuration Parameters	14	5.1.3 Diagnostic Indicator Table	47
2.3.4 Model 706 FF Device-Specific Configuration Parameters	15	5.1.4 Diagnostic Help	50
2.4 Analog Input Block (AI)	15	5.2 Diagnostic Parameters	51
2.4.1 AI Block Parameters	15	5.3 FOUNDATION fieldbus Segment Checklist	54
2.4.2 AI Block Diagnostics	18	Appendix A	55
2.4.3 Local Display of AI Block	18		
2.4.3.1 AI Out Display Screens	19		
2.4.4 AI Block Configuration	20		
2.4.5 Simulation Feature	21		
2.5 PID Block	21		
2.5.1 PID Block Parameters	21		
3.0 Advanced Function Blocks	24		
3.1 Integrator Block (IT)	24		
3.2 Arithmetic Block (AR)	26		
3.3 Input Selector Block (ISEL)	29		
3.4 Signal Characterizer Block (SC)	30		

1.0 FOUNDATION Fieldbus™

1.1 Overview

FOUNDATION fieldbus™ is a digital communications system that serially interconnects devices in the field. A Fieldbus system is similar to a Distributed Control System (DCS) with two exceptions:

- Although a Foundation fieldbus™ system can use the same physical wiring as 4–20 mA device, Fieldbus devices are not connected point to point, but rather are multidropped and wired in parallel on a single pair of wires (referred to as a segment).
- Foundation fieldbus™ is a system that allows the user to distribute control across a network. Fieldbus devices are smart and can actually maintain control over the system.

Unlike 4–20 mA analog installations in which the two wires carry a single variable (the varying 4–20 mA current), a digital communications scheme such as FOUNDATION fieldbus™ considers the two wires as a network. The network can carry many process variables as well as other information. The ECLIPSE Model 706FF transmitter is a FOUNDATION fieldbus™ registered device that communicates with the H1 FOUNDATION fieldbus™ protocol operating at 31.25 kbits/sec. The H1 physical layer is an approved IEC 61158 standard.

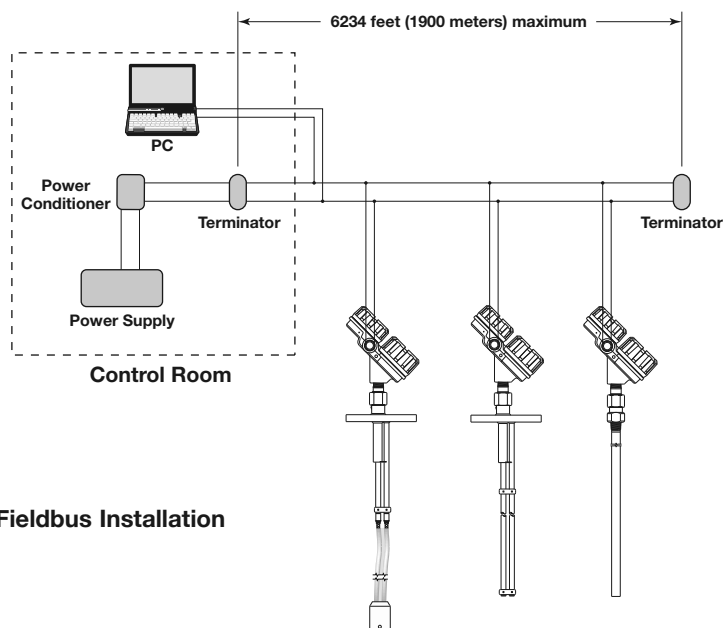

Typical Fieldbus Installation

Details regarding cable specifications, grounding, termination, and other physical layer network information can be found in IEC 61158 or the wiring installation application guide AG-140 at www.fieldbus.org.

1.2 Device Description (DD)

An important requirement of Fieldbus devices is the concept of interoperability, defined as “the ability to operate multiple devices in the same system, regardless of manufacturer, without loss of functionality.”

Device Description (DD) technology is used to achieve this interoperability. The DD provides extended descriptions for each object and provides pertinent information needed by the host system. DDs are similar to the drivers that your personal computer (PC) uses to operate peripheral devices connected to it. Any Fieldbus host system can operate with a device if it has the proper DD and Common File Format (CFF) for that device.

The most recent DD and CFF files can be found on the FOUNDATION fieldbus™ web site at www.fieldbus.org or at www.magnetrol.com.

NOTE: Please consult your host system vendor for any host-specific files that may be needed.

1.2.1 FOUNDATION fieldbus™ DD Revision Table

FOUNDATION fieldbus™ Version	FOUNDATION fieldbus™ Release Date	Compatible with Model 706 Software
Dev V1 DD V1	June 2013	Version 1.0a or later

1.3 Link Active Scheduler (LAS)

The default operating class of the Eclipse Model 706FF with FOUNDATION fieldbus™ is a Basic device. However, it is capable of being configured as a Link Active Scheduler (LAS).

The LAS controls all communication on a FOUNDATION fieldbus™ segment. It maintains the “Live List” of all devices on a segment and coordinates both the cyclic and acyclic timing.

The primary LAS is usually maintained in the host system, but in the event of a failure, all associated control can be transferred to a backup LAS in a field device such as the Eclipse® Model 706 FF.

NOTES:

- 1) The Eclipse Model 706 is normally shipped from the factory with Device Class set to Basic.
- 2) The operating class can be changed from Basic to LAS using a FOUNDATION fieldbus™ configuration tool.

1.4 Intrinsic Safety

The H1 physical layer supports Intrinsic Safety (IS) applications with bus-powered devices. To accomplish this, an Intrinsically Safe barrier or galvanic isolator is placed between the power supply in the safe area and the device in the hazardous area.

H1 also supports the Fieldbus Intrinsically Safe Concept (FISCO) model which allows more field devices in a network. The FISCO model considers the capacitance and inductance of the wiring to be distributed along its entire length. Therefore, the stored energy during a fault will be less and more devices are permitted on a pair of wires. Instead of the conservative entity model, which only allows about 90 mA of current, the FISCO model allows a maximum of 110 mA for Class II C installations and 240 mA for Class II B installations.

FISCO certifying agencies have limited the maximum segment length to 1000 meters because the FISCO model does not rely on standardized ignition curves.

The ECLIPSE Model 706 FF is available with entity IS, FISCO IS, FNICO non-incendive, or explosion proof approvals.

2.0 Standard Function Blocks

2.1 Overview

The function of a FOUNDATION fieldbus™ device is determined by the arrangement of a system of blocks defined by the Fieldbus foundation. The types of blocks used in a typical User Application are described as either Standard or Advanced.

Function Blocks are built into the FOUNDATION fieldbus™ devices as needed to provide the desired control system behavior. The input and output parameters of function blocks can be linked over the Fieldbus and there can be numerous function blocks in a single User Application.

The Enhanced ECLIPSE Model 706FF is a Guided Wave Radar (GWR) level transmitter with the following standard FOUNDATION fieldbus™ Function Blocks:

- One (1) Resource Block (RB)
- Three (3) Custom Transducer Blocks (TB)
- Eight (8) Analog Input Function Blocks (AI)
- Two (2) PID Blocks (PID)

With Advanced Function Blocks:

- One (1) Integrator Block (IT)
- One (1) Arithmetic Block (AR)
- One (1) Input Selector Block (IS)
- One (1) Signal Characterizer Block (SC)

The idea of Function Blocks, which a user can customize for a particular application, is a key concept of Fieldbus topology. Function Blocks consist of an algorithm, inputs and outputs, and a user-defined name.

The Transducer Block (TB) output is available to the network through the Analog Input (AI) blocks. Refer to Section 2.3 for additional information on the Transducer Blocks.

The AI blocks take the TB values and make them available as an analog value to other function blocks. The AI blocks have scaling conversion, filtering, and alarm functions. Refer to Section 2.4 for additional information on the Analog Input Blocks.

As shown in the diagram at left, the End User needs the Process Variable value as an Analog Input to their fieldbus network.

Model 706 – Transducer Block

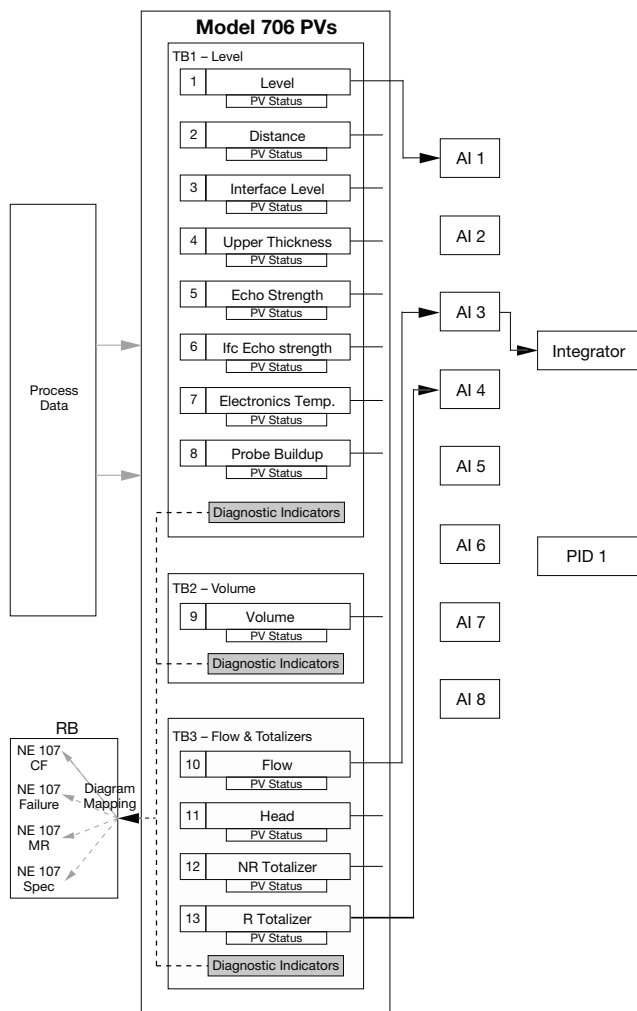

Note: Number next to PV refers to channel number in the AI Blocks.

2.1.1 Universal fieldbus Block Parameters

The following are general descriptions of the parameters common to all function blocks. Additional information for a given parameter may be described later in a section that describes the specific block.

ST_REV: a read only parameter that gives the revision level of the static data associated with the block. This parameter will be incremented each time a static parameter attribute value is written and is a vehicle for tracking changes in static parameter attributes.

TAG_DESC: a user assigned parameter that describes the intended application of any given block.

STRATEGY: a user assigned parameter that identifies groupings of blocks associated with a given network connection or control scheme.

ALERT_KEY: a user assigned parameter which may be used in sorting alarms or events generated by a block.

MODE_BLK: a structured parameter composed of the actual mode, the target mode, the permitted mode(s), and the normal mode of operation of a block.

- Target: The mode to “go to”
- Actual: The mode the “block is currently in”
- Permitted: Allowed modes that target may take on
- Normal: Most common mode for target

NOTES:

- 1) It may be required to change the the MODE_BLK target parameter to OOS (out of service) to change configuration parameters in that specific function block. (When in OOS, the normal algorithm is no longer executed and any outstanding alarms are cleared.)
- 2) All blocks must be in an operating mode for the device to operate. This requires the Resource Block and the Transducer Block to be in “AUTO” before the specific function block can be placed in a mode other than OOS (out of service).

BLOCK_ERR: a parameter that reflects the error status of hardware or software components associated with, and directly affecting, the correct operation of a block.

NOTE: A BLOCK_ERR of “Simulation Active” in the Resource Block does not mean simulation is active—it merely indicates that the simulation (hardware) enabling jumper is present and soft simulation disable is set to NO. (See page 13 and refer to Section 2.4.5 for additional information).

2.2 Resource Block

The RESOURCE BLOCK describes the characteristics of the FOUNDATION fieldbus™ device such as the device name, manufacturer, and serial number. As it only contains data specific to the Eclipse Model 706 FF transmitter, it has no control function.

2.2.1 Resource Block Parameters

MODE_BLK: Must be in AUTO in order for the remaining function blocks in the transmitter to operate.

NOTE: A Resource Block in “out of service” mode will stop all function block execution in the transmitter.

RS_STATE: Identifies the state of the RESOURCE block state machine. Under normal operating conditions, it should be “On-Line.”

DD_RESOURCE: A string identifying the tag of the resource that contains the Device Description for this device.

MANUFAC_ID: Contains Magnetrol International’s FOUNDATION fieldbus™ manufacturer’s ID number, which is 0x000156.

DEV_TYPE: The model number of the ECLIPSE Model 706 FF transmitter (0x0005). It is used by the Host System and other fieldbus interface devices to locate the Device Descriptor (DD) file.

DEV_REV: Contains the firmware revision of the ECLIPSE Model 706 FF transmitter and is used by the Host System and other fieldbus interface devices to correctly select the associated DD.

DD_REV: Contains the revision of the DD associated with the version of firmware in the ECLIPSE Model 706 FF transmitter. It is used by the Host System and other Fieldbus interface devices to correctly select the associated DD.

RESTART: Default and Processor are the available selections. Default will reset the Model 706 to the default factory block configuration.

NOTE: As RESTART DEFAULT will set most function block configuration parameters to their default values. Devices need to be reconfigured following activation of this function.

FEATURES: A list of the features available in the transmitter, such as Reports and Soft Write Lock.

FEATURES_SEL: Allows the user to turn Features on or off.

CYCLE_TYPE: Identifies the block execution methods that are available.

CYCLE_SEL: Allows the user to select the block execution method.

MIN_CYCLE_T: The time duration of the shortest cycle interval. It puts a lower limit on the scheduling of the resource.

NV_CYCLE_T: The minimum time interval between copies of non-volatile (NV) parameters to NV memory. NV memory is only updated if there has been a significant change in the dynamic value and the last value saved will be available for the restart procedure.

NOTE: After completing a download, allow several seconds before removing power from the ECLIPSE Model 706 FF transmitter to ensure that all data has been saved.

FREE_SPACE: Shows the amount of available memory for further configuration. The value is zero percent in a pre-configured device.

FREE_TIME: The amount of the block processing time that is free to process additional blocks.

SHED_RCAS: The time duration at which to give up computer writes to function block RCas locations.

SHED_ROUT: The time duration at which to give up computer writes to function block ROut locations.

FAULT_STATE, SET_FSTATE, CLR_FSTATE: These only apply to output function blocks. (The Model 706FF has no output function blocks).

MAX_NOTIFY: The maximum number of alert reports that the transmitter can send without getting a confirmation.

LIM_NOTIFY: the maximum numbers of unconfirmed alert notify messages allowed. No alerts are reported if set to zero.

CONFIRM_TIME: the time that the transmitter will wait for confirmation of receipt of a report before trying again. Retry will not occur if **CONFIRM_TIME** = 0.

WRITE_LOCK: When set to **LOCKED**, will prevent any external change to the static or non-volatile data base in the Function Block Application of the transmitter. Block connections and calculation results will proceed normally, but the configuration will be locked.

UPDATE_EVT (Update Event): Is an alert generated by a write to the static data in the block.

BLOCK_ALM (Block Alarm): Is used for configuration, hardware, connection, or system problems in the block. The cause of any specific alert is entered in the subcode field.

ALARM_SUM (Alarm Summary): Contains the current alert status, the unacknowledged states, the unreported states, and the disabled states of the alarms associated with the block.

ACK_OPTION (Acknowledge Option): Selects whether alarms associated with the block will be automatically acknowledged.

WRITE_PRI (Write Priority): The priority of the alarm generated by clearing the write lock.

WRITE_ALM (Write Alarm): The alert generated if the write lock parameter is cleared.

ITK_VER (ITK Version): Contains the version of the Interoperability Test Kit (ITK) used by the Fieldbus Foundation during their interoperability testing.

COMPATIBILITY_REV: This parameter is intended to assist users and host system in device replacement scenarios. It is a read-only parameter and the value of the COMPATIBILITY_REV is defined by the device developer and manufacturer. In such device replacement scenario the DEV_REV value of the replaced device is equal or greater than the COMPATIBILITY_REV value of the new device.

2.2.2 Additional Resource Block Parameters

Additional parameters are available within the resource block for use with NE-107 to aid in communicating device conditions to the user.

FD_VER: Major version of the Field Diagnostic specification to which this device conforms.

FD_FAIL_ACTIVE: For error conditions that have been selected for the FAIL alarm category, this parameter reflects those that have been detected as active.

FD_OFFSPEC_ACTIVE: For error conditions that have been selected for the OFFSPEC alarm category, this parameter reflects those that have been detected as active.

FD_MAINT_ACTIVE: For error conditions that have been selected for the MAINT alarm category, this parameter reflects those that have been detected as active.

FD_CHECK_ACTIVE: For error conditions that have been selected for the CHECK alarm category, this parameter reflects those that have been detected as active.

FD_FAIL_MAP: Maps conditions to be detected as active for the FAIL alarm category.

FD_OFFSPEC_MAP: Maps conditions to be detected as active for the OFFSPEC alarm category.

FD_MAINT_MAP: Maps conditions to be detected as active for the MAINT alarm category.

FD_CHECK_MAP: Maps conditions to be detected as active for the CHECK alarm category.

FD_FAIL_MASK: Used to suppress an alarm from being broadcast for single or multiple conditions that are active in the FAIL alarm category.

FD_OFFSPEC_MASK: Used to suppress an alarm from being broadcast for single or multiple conditions that are active in the OFFSPEC alarm category.

FD_MAINT_MASK: Used to suppress an alarm from being broadcast for single or multiple conditions that are active in the MAINT alarm category.

FD_CHECK_MASK: Used to suppress an alarm from being broadcast for single or multiple conditions that are active in the CHECK alarm category.

FD_FAIL_ALM: Used to broadcast a change in the associated active conditions, which are not masked, for the FAIL alarm category.

FD_OFFSPEC_ALM: Used to broadcast a change in the associated active conditions, which are not masked, for the OFFSPEC alarm category.

FD_MAINT_ALM: Used to broadcast a change in the associated active conditions, which are not masked, for the MAINT alarm category.

FD_CHECK_ALM: Used to broadcast a change in the associated active conditions, which are not masked, for the CHECK alarm category.

FD_FAIL_PRI: Specifies the priority of the FAIL alarm category.

FD_OFFSPEC_PRI: Specifies the priority of the OFFSPEC alarm category.

FD_MAINT_PRI: Specifies the priority of the MAINT alarm category.

FD_CHECK_PRI: Specifies the priority of the CHECK alarm category.

FD_SIMULATE: Diagnostic conditions can be manually supplied when simulation is enabled.

FD_RECOMMEN_ACT: Describes what actions can be taken to address an active diagnostic condition.

FD_EXTENDED_ACTIVE_1: For error conditions that have been selected in the Extended_Map_1 parameter, this parameter reflects those that have been detected as active.

FD_EXTENDED_MAP_1: Allows the user finer control in selecting multiple conditions contributing to a single condition that may be mapped for the various alarm categories.

Manufacturer-Specific Parameters:

SOFT_SIMULATION_DISABLE: If set to yes, enabling of simulation is disallowed regardless of the presence of the simulation jumper, and the “simulation” indicator will be cleared in the Block Error parameter. If set to no, simulation can only be enabled if the simulation jumper is present which also sets the “simulation” indicator in the Block Error parameter.

SERIAL_NUMBER: Read-only parameter that corresponds to “Magnetrol Serial Number” in the Transducer Block.

FIRMWARE_VERSION: Read-only parameter that corresponds to “Firmware Version” in the Transducer Block.

HARDWARE_VERSION: Read-only parameter that corresponds to “Hardware Version” in the Transducer Block.

2.3 Transducer Block

The three TRANSDUCER blocks (TB) contained within the ECLIPSE Model 706 FF transmitter are custom blocks containing parameters that are pertinent to the transmitter itself.

TRANSDUCER Block 1 (used for level and interface operation) contains information such as the Configuration, Diagnostics, Calibration data, output level and Status information.

TRANSDUCER Blocks 2 and 3 contain volume and flow parameters respectively.

The read-only parameters and read-write parameters within the TB are grouped in a useful configuration.

- The read-only parameters report the block status and operation modes.
- The read-write parameters affect both the operation of the function block and the transmitter itself.

NOTE: The Transducer Block will automatically be changed to “Out of Service” when the local interface (keypad) is used to change a static parameter online. The Transducer Block must be manually placed back in service from the Host System to resume operation.

2.3.1 Transducer Block Parameters

The first six parameters in the TRANSDUCER Block are the universal parameters discussed in section 4.1.1. After the universal parameters, six additional parameters are required for Transducer Blocks. The most notable of these parameters are **UPDATE_EVT** and **BLOCK_ALM**. It should be noted that these six additional parameters must exist but do not have to be implemented.

An important device-specific parameter found later in the TRANSDUCER Block list is **DEVICE_STATUS**, which displays the status of the device. If more than one message exists, then the messages are displayed in priority order.

If **DEVICE_STATUS** indicates a problem, refer to Section 5.2, Troubleshooting.

For a complete list of Transducer Block Parameters, refer to table in the Appendix.

NOTE: The user should compare the DD file and revision number of the device with the HOST system to ensure they are at the same revision level.

Please refer to the DD Revision Table Section 1.2.1.

Please refer to Appendix A for a complete list of the three Transducer Block parameter sets.

2.3.2 Password Parameters

To change a parameter at the local user interface, a value matching the user password must be entered (Default = 1). If a static parameter is changed from the local user interface, the Associated Transducer Block goes Out of Service (OOS).

Please refer to the Section 4.3 for additional information regarding passwords.

After 5 minutes with no keypad activity, the entered password expires. However, the device must be placed back in service from the Host System.

From the Host system network, the instrument always behaves as if it is in the user password mode by default. In other words, it is not necessary to enter the user password in order to write most parameters from the Host system.

2.3.3 Eclipse Model 706 FF Configuration Parameters

One of the main advantages of the Eclipse Model 706 FF GWR transmitter is that the device can be delivered pre-configured to the user.

On the other hand, part of the advantage of FOUNDATION fieldbus™ is to provide the ability to monitor changes and make adjustments to a transmitter. The Fieldbus™ concept allows a user to make adjustments if deemed necessary.

2.3.4 Eclipse Model 706 FF Device-Specific Configuration Parameters

Please refer to ECLIPSE Model 706 I/O Manual BE57-606 for detailed information on the Model 706 device-specific configuration parameters.

2.4 Analog Input Block

The ANALOG INPUT (AI) block takes the ECLIPSE Model 706 FF input data, selected by channel number, and makes it available to other function blocks at its output.

The channel selections are:

Transducer Blocks	Process Variable	Channel Parameter Value (AI Blocks)
TB1 – Level	Level	1
	Interface Level	2
	Upper Thickness	3
	Distance	4
	Echo Strength	5
	lfc Echo Strength	6
	Electronics Temperature	7
	Probe Buildup	8
TB2 – Volume	Volume	9
TB3 – Flow and Totalizers	Flow	10
	Head	11
	NR Totalizer	12
	R Totalizer	13

2.4.1 AI Block Parameters

The following are general descriptions of the parameters common to all function blocks. Additional information for a given parameter may be described later in a section that describes the specific block.

ST_REV: a read only parameter that gives the revision level of the static data associated with the block. This parameter will be incremented each time a static parameter attribute value is written and is a vehicle for tracking changes in static parameter attributes.

TAG_DESC: a user assigned parameter that describes the intended application of any given block.

STRATEGY: a user assigned parameter that identifies groupings of blocks associated with a given network connection or control scheme.

ALERT_KEY: a user assigned parameter which may be used in sorting alarms or events generated by a block.

MODE_BLK: a structured parameter composed of the actual mode, the target mode, the permitted mode(s), and the normal mode of operation of a block.

- Target: The mode to “go to”
- Actual: The mode the “block is currently in”
- Permitted: Allowed modes that target may take on
- Normal: Most common mode for target

PV: Either the primary analog value for use in executing the function, or a process value associated with it.

OUT: The primary analog value calculated as a result of executing the function block.

SIMULATE: Allows the transducer analog input or output to the block to be manually supplied when simulate is enabled. When simulate is disabled, the simulate value and status track the actual value and status. Please refer to Section 2.4.5 for additional information.

XD_SCALE: The high and low scale values, Engineering Units, and number of digits to the right of the decimal point used with the value obtained from the transducer for a specified channel.

OUT_SCALE: The high and low scale values, Engineering Units, and number of digits to the right of the decimal point to be used in displaying the OUT parameter.

GRANT_DENY: Options for controlling access of host computers and local control panels to operating, tuning, and alarm parameters of the block.

IO_OPTS: Option which the user may select to alter input and output block processing.

STATUS_OPTS: Options which the user may select in the block processing of status.

CHANNEL: The number of the logical hardware channel that is connected to this I/O block. (This information defines the transducer to be used going to or from the physical world).

L_TYPE: Determines if the values passed by the transducer block to the AI block may be used directly (Direct), or if the value is in different units and must be converted linearly (Indirect), using the input range defined for the transducer and the associated output range.

LOW_CUT: Limit used in square root processing.

PV_FTIME: Time constant of a single exponential filter for the PV, in seconds.

FIELD_VAL: Raw value of the field device in % of PV range, with a status reflecting the Transducer condition before signal characterization (L_TYPE) or filtering (PV_FTIME).

UPDATE_EVT: This alert is generated by any change to the static data.

BLOCK_ALM: The block alarm is used for all configuration, hardware, or system problems in the block.

ALARM_SUM: The current alert status, unacknowledged states, unreported states, and disabled states of the alarms associated with the function block.

ACK_OPTION: Selection of whether alarms associated with the function block will be automatically acknowledged.

ALARM_HYS: Amount the PV must return within the alarm limits before the alarm condition clears. Alarm hysteresis expressed as a percent of the span of the PV.

HI_HI_PRI: Priority of the high high alarm.

HI_HI_LIM: The setting for high high alarm in engineering units.

HI_PRI: Priority of the high alarm.

HI_LIM: The setting for high alarm in engineering units

LO_PRI: Priority of the low alarm.

LO_LIM: The setting for low alarm in engineering units.

LO_LO_PRI: Priority of the low low alarm.

LO_LO_LIM: The setting for low low alarm in engineering units.

HI_HI_ALM: The status for high high alarm and its associated time stamp.

HI_ALM: Status for high alarm and associated time stamp.

LO_ALM: Status for low alarm and associated time stamp.

LO_LO_ALM: The status for low low alarm and its associated time stamp.

BLOCK_ERR_DESC: Reports more specific details regarding some errors reported through **BLOCK_ERR**.

The **MODE_BLK** parameter (within both the **TB** and **AI** Blocks) must be set to **AUTO** to pass the **PV** Value through the **AI** to the network.

Transducer scaling, called **XD_SCALE** is applied to the **PV** from the **CHANNEL** to produce the **FIELD_VAL** in percent.

- Valid **XD_SCALE** engineering units depend on the Channel Type.

2.4.2 AI Block Diagnostics

The **AI** blocks can display a **BLOCK_ERR** diagnostic when:

1. The Channel is not set correctly. (Refer to Default Channel Table in Section 2.4).
2. **XD_SCALE** does not have suitable engineering units
3. The **SIMULATE** parameter is active.
4. **AI** block **MODE** is **O/S** (out of service).

NOTE: This can be caused by the Resource Block being **OOS** or the **AI** Block not scheduled for execution.

5. **L-TYPE** not set or set to **Direct** with improper **OUT_SCALE**.

The **AI** block uses the **STATUS_OPTS** setting and the **TRANSDUCER PV LIMIT** value to modify the **AI PV** and **OUT QUALITY**.

A Damping Filter is a feature of the **AI** block. The **PV_FTIME** parameter is a time constant of a single exponential filter for the **PV**, in seconds. This parameter can be used to dampen out fluctuation in level due to excessive turbulence.

The **AI** block also has multiple **ALARM** functions that monitor the **OUT** parameter for out of bound conditions.

2.4.3 Local Display of Analog Input Transducer Block Output

The **ECLIPSE Model 706FF** transmitter incorporates a useful feature that allows the **Analog Input (AI)** block **Out** values to be displayed on the local **LCD**.

NOTE: There are many reasons that AI block Out values can deviate from the measurement value originating in the Transducer block, and because the keypad and local display will only provide access to Transducer block parameters, there is no way to change (or view) the other fieldbus configuration items affecting the AI block output using the keypad and LCD.

In other words, these screens should only be considered as measured value indicators for configured transmitters. For example:

- The screens are not used for commissioning or diagnostic/troubleshooting purposes.
- Prior to full fieldbus configuration (transmitter assigned a permanent address, AI block(s) configured and scheduled for execution, etc.), the value displayed will not reflect the transducer measurement.

2.4.3.1 AI Out Display Screens

The Analog Input Block Out values can be conditionally displayed as part of the “rotating” home menu screens. A representative example is shown at left.

The screens will be formatted as shown with:

- Physical Device Tag (Selectable)
- Measured Value Status (Bad, Good, Uncertain)
- Bar Graph

For example, “AI1_Level” would be the most commonly used AI Out screen.

“AI2---” would be displayed when the channel value is 0 [uninitialized] for AI block 2.

Because the Model 706 transmitter has eight (8) Analog Input blocks, any or all of which may be used in particular applications, a Transducer block parameter controls which AI block Out values will be displayed on the LCD.

Any or all (or none) of the AI block Out values can be selected for display on the LCD.

NOTE: In the photo at left, status is shown as “Bad out of Service”. This message would be shown prior to commissioning.



LCD Screen

2.4.4 AI Block Configuration

Below are shown some examples of various typical AI Block configurations.

Example 1: standard configuration for transmitter with probe of length PL inches or cm.
[setup by factory as part of final assembly procedure]

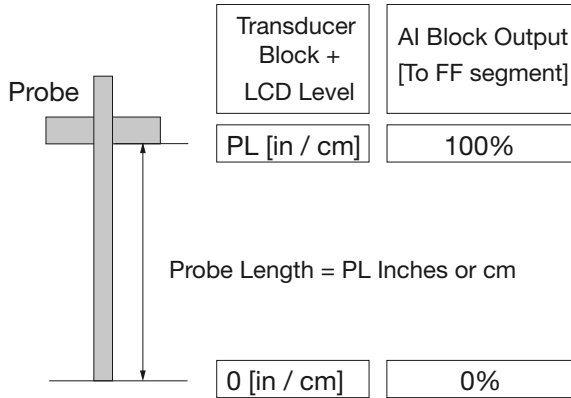

Configuration	
Probe Length	PL
Level Offset	0
XD Scale EU at 0%	0
XD Scale EU at 100%	PL
XD Scale Units	in/cm
Out Scale EU at 0%	0
Out Scale EU at 100%	100
Out Scale Units	%
L Type	Indirect

Example 2: end user desires 0 to 100% output for a subset of the measureable region [probe]
[e.g., for a chamber application]

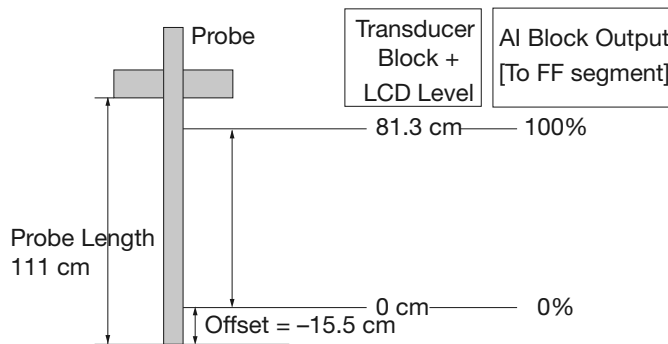

Configuration	
Probe Length	111
Level Offset	-15.5
XD Scale EU at 0%	0
XD Scale EU at 100%	81.3
XD Scale Units	cm
Out Scale EU at 0%	0
Out Scale EU at 100%	100
Out Scale Units	%
L Type	Indirect

Example 3: same configuration as previous except Direct [no] scaling setup in AI block
Output to FF segment is in cm

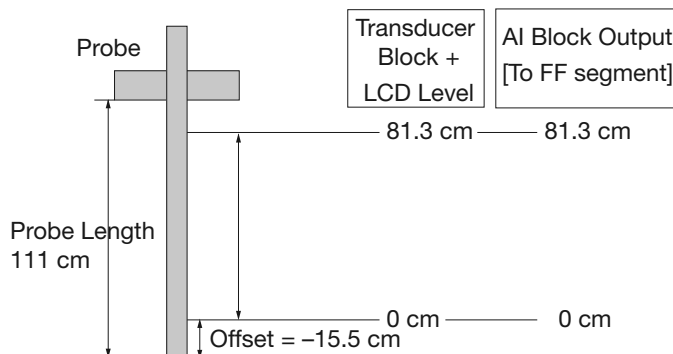

Configuration	
Probe Length	111
Level Offset	-15.5
XD Scale EU at 0%	0
XD Scale EU at 100%	81.3
XD Scale Units	cm
Out Scale EU at 0%	0
Out Scale EU at 100%	81.3
Out Scale Units	cm
L Type	Direct

2.4.5 Simulation Feature

The ECLIPSE Model 706 with FOUNDATION fieldbus™ supports the Simulate feature in the Analog Input block. The Simulate feature is typically used to exercise the operation of an AI block by simulating a TRANSDUCER block input.

This feature cannot be activated without the placement of a hardware jumper. This jumper is installed as standard on the ECLIPSE Model 706, and is placed under the display module to avoid inadvertent disabling of this feature. Refer to figure at left for jumper location.

NOTE: A BLOCK_ERR of “Simulation Active” in the Resource Block does not mean simulation is active—it merely indicates that the simulation (hardware) enabling jumper is present.

- The jumper may be removed to eliminate the BLOCK_ERR, but please note that this will permanently disable the Simulate feature.
- Refer to page 13 for additional information on the SOFT_SIMULATION_DISABLE parameter in the resource block.



Remove jumper to disable simulation

2.5 PID Block

The PID Function Block contains the logic necessary to perform Proportional/Integral/Derivative (PID) control. The block provides filtering, set point and rate limits, feed-forward support, output limits, error alarms, and mode shedding.

Although most other function blocks perform functions specific to the associated device, the PID block may reside in any device on the network. This includes a valve, a transmitter, or the host itself.

The ECLIPSE Model 706 FF PID Block implementation follows the specifications documented by the Fieldbus Foundation.

2.5.1 PID Block Parameters

ACK_OPTION: Used to set auto acknowledgement of alarms.

ALARM_HYS: The amount the alarm value must return to before the associated active alarm condition clears.

ALARM_SUM: The summary alarm is used for all process alarms in the block.

ALERT_KEY: The identification number of the plant unit.

BAL_TIME: The specified time for the internal working value of bias to return to the operator set bias.

BKCAL_IN: The analog input value and status for another blocks BKCAL_OUT output.

BKCAL_HYS: The amount the output must change away from its output limit before the limit status is turned off, expressed as a percent of the span of the output.

BKCAL_OUT: The value and status required by the BKCAL_IN input for another block.

BLOCK_ALM: Used for all configuration, hardware, or system problems in the block.

BLOCK_ERR: Reflects the error status associated with the hardware or software components associated with a block.

BYPASS: Used to override the calculation of the block.

CAS_IN: The remote setpoint value from another block.

CONTROL_OPTS: Allows one to specify control strategy options.

DV_HI_ALM: The DV HI alarm data.

DV_HI_LIM: The setting for the alarm limit used to detect the deviation high alarm condition.

DV_HI_PRI: The priority of the deviation high alarm.

DV_LO_ALM: The DV LO alarm data.

DV_LO_LIM: The setting for the alarm limit used to detect the deviation low alarm condition.

DV_LO_PRI: The priority of the deviation low alarm.

FF_GAIN: The feedforward gain value.

FF_SCALE: The high and low scale values associated with FF_VAL.

FF_VAL: The feedforward control input value and status.

GAIN: The proportional gain value. This value cannot equal zero.

GRANT_DENY: Options for controlling access of host computers to alarm parameters of the block.

HI_ALM: The HI alarm data.

HI_HI_ALM: The HI HI alarm data.

HI_HI_LIM: The setting for the alarm limit used to detect the HI HI alarm condition.

HI_HI_PRI: The priority of the HI HI Alarm.

HI_LIM: The setting for the alarm limit used to detect the HI alarm condition.

HI_PRI: The priority of the HI alarm.

IN: The connection for the PV input from another block.

LO_ALM: The LO alarm data.

LO_LIM: The setting for the alarm limit used to detect the LO alarm condition.

LO_LO_ALM: The LO_LO alarm data.

LO_LO_LIM: The setting for the alarm limit used to detect the LO_LO alarm condition.

LO_LO_PRI: The priority of the LO_LO alarm.

LO_PRI: The priority of the LO alarm.

MODE_BLK: The actual, target, permitted, and normal modes of the block.

OUT: The block input value and status.

OUT_HI_LIM: The maximum output value allowed.

OUT_LO_LIM: The minimum output value allowed.

OUT_SCALE: The high and low scale values associated with OUT.

PV: The process variable use in block execution.

PV_FTIME: The time constant of the first order PV filter.

PV_SCALE: The high and low scale values associated with PV.

RATE: The derivative action time constant.

RCAS_IN: Target setpoint and status that is provided by a supervisory host.

RCAS_OUT: Block setpoint and status that is provided to a supervisory host.

RESET: The integral action time constant.

ROUT_IN: Block output that is provided by a supervisory host.

ROUT_OUT: Block output that is provided to a supervisory host.

SHED_OPT: Defines action to be taken on remote control device timeout.

SP: The target block setpoint value.

SP_HI_LIM: The highest SP value allowed.

SP_LO_LIM: The lowest SP value allowed.

SP_RATE_DN: Ramp rate for downward SP changes.

SP_RATE_UP: Ramp rate for upward SP changes.

STATUS_OPTS: Allows one to select options for status handling and processing.

STRATEGY: Can be used to identify grouping of blocks.

ST_REV: The revision level of the static data associated with the function block.

TAG_DESC: The user description of the intended application of the block.

TRK_IN_D: Discrete input that initiates external tracking.

TRK_SCALE: The high and low scale values associated with TRK_VAL.

TRK_VAL: The value applied to OUT in LO mode.

UPDATE_EVT: This alert is generated by any changes to the static data.

BLOCK-ERR-DESC: Reports more specific details regarding some errors reported through BLOCK_ERR.

3.0 Advanced Function Blocks

3.1 Integrator Block (IT)

The Integrator (IT) function block integrates one or two variables over time. The block compares the integrated or accumulated value to pre-trip and trip limits and generates discrete output signals when the limits are reached.

ST_REV: The revision level of the static data associated with the function block.

TAG_DESC: The user description of the intended application of the block.

STRATEGY: The strategy field can be used to identify grouping of blocks.

ALERT_KEY: The identification number of the plant unit. This information may be used in the host for sorting alarms.

MODE_BLK: The actual, target, permitted, and normal modes of the block.

- Target: The mode to “go to”
- Actual: The mode the “block is currently in”
- Permitted: Allowed modes that target may take on
- Normal: Most common mode for target

BLOCK_ERR: The summary of active error conditions associated with the block. The block error for the Integrator function block is Out of service.

TOTAL_SP: The set point for a batch totalization.

OUT: The block output value and status.

OUT_RANGE: The high and low scale values, engineering units code, and number of digits to the right of the decimal point associated with OUT.

GRAND_DENY: Options for controlling access of host computers and local control panels to operating, tuning, and alarm parameters of the block (not used by the device).

STATUS_OPTS: Allows you to select option for status handling and processing. The supported status option for the Integrator block is: "Uncertain if Manual mode."

IN_1: The block input value and status.

IN_2: The block input value and status.

OUT_TRIP: The first discrete output.

OUT_PTRIP: The second discrete output.

TIME_UNIT1: Converts the rate time, units in seconds.

TIME_UNIT2: Converts the rate time, units in seconds.

UNIT_CONV: Factor to convert the engineering units of IN_2 into the engineering units of IN_1.

PULSE_VAL1: Determines the mass, volume or energy per pulse.

PULSE_VAL2: Determines the mass, volume or energy per pulse.

REV_FLOW1 : Indicates reverse flow when "true"; 0- Forward, 1- Reverse

REV_FLOW2: Indicates reverse flow when "true"; 0- Forward, 1- Reverse

RESET_IN: Resets the totalizers

STOTAL: Indicates the snapshot of OUT just before a reset.

RTOTAL: Indicates the totalization of "bad" or "bad" and "uncertain" inputs, according to INTEG_OPTIONS.

SRTOTAL: The snapshot of RTOTAL just before a reset

SSP: The snapshot of TOTAL_SP

INTEG_TYPE: Defines the type of counting (up or down) and the type of resetting (demand or periodic)

INTEG_OPTIONS : A bit string to configure the type of input (rate or accumulative) used in each input, the flow direction to be considered in the totalization, the status to be considered in TOTAL and if the totalization residue should be used in the next batch (only when INTEG_TYPE=UP_AUTO or DN_AUTO).

CLOCK_PER: Establishes the period for periodic reset, in hours.

PRE_TRIP: Adjusts the amount of mass, volume or energy that should set OUT_PTRIP when the integration reaches (TOTAL_SP-PRE_TRIP) when counting up of PRE_TRIP when counting down.

N_RESET: Counts the number of resets. It cannot be written or reset.

PCT_INC: Indicates the percentage of inputs with “good” status compared to the ones with “bad or “uncertain” and “bad” status.

GOOD_LIMIT: Sets the limit for PCT_INC. OUT. Receives the status “Good” is $PCT_INCL \geq GOOD_LIM$.

UNCERTAIN_LIMIT: Sets the limit for PCT_INC. OUT receives the status “uncertain” if $PCT_INC \geq UNCERT.LIM$.

OP_CMD_INT: Operator command RESET Resets the totalizer

OUTAGE_LIMIT: The maximum tolerated duration for power failure

RESET_CONFIRM: Momentary discrete value with can be written by a host to enable further resets, if the option “Confirm reset” in INTEG_OPTIONS is chosen.

UPDATE_EVT: This alert is generated by any changes to the static data.

BLOCK_ALM: Used for all configuration, hardware, connection failure, or system problems in the block.

BLOCK_ERR_DESC: Reports more specific details regarding some errors reported through BLOCK_ERR.

3.2 Arithmetic Block (AR)

The Arithmetic function block provides the ability to configure a range extension function for a primary input and applies the nine (9) different arithmetic types as compensation to or augmentation of the range extended input.

The nine (9) arithmetic functions are:

- Flow Compensation Linear
- Flow Compensation Square Root
- Flow Compensation Approximate
- Btu Flow
- Traditional Multiply and Divide
- Average
- Summer
- Fourth Order Polynomial
- Simple HTG Compensate Level

ST_REV: The revision level of the static data associated with the function block. The revision value will increment each time a static parameter value in the block is changed.

TAG_DESC: The user description of the intended application of the block.

STRATEGY: The strategy field can be used to identify grouping of blocks. This data is not checked or processed by the block.

ALERT_KEY: The identification number of the plant unit. This information may be used in the host for sorting alarms, etc.

MODE_BLK: The actual, target, permitted, and normal modes of the block.

- Target: The mode to “go to”
- Actual: The mode the “block is currently in”
- Permitted: Allowed modes that target may take on
- Normal: Most common mode for target

BLOCK_ERR: This parameter reflects the error status associated with the hardware or software components associated with a block. It is a bit string so that multiple errors may be shown.

PV: The primary analog value for use in executing the function, or a process value associated with it.

OUT: The analog output value and status.

PRE_OUT: Displays what would be the OUT value if the mode was “Auto” or lower.

PV_SCALE: Associated with the PV.

OUT_RANGE: The high and low scale values, engineering units code, and number of digits to the right of the decimal point associated with OUT.

GRANT_DENY: Options for controlling access of host computers and local control panels to operating, tuning, and alarm parameters of the block.

INPUT_OPTIONS: Option bit string for handling the status of the auxiliary inputs.

IN: The block input value and status.

IN_LO: Input of the low range transmitter, in a range extension application.

IN-1, IN-2, IN-3: Inputs combined with the PV in a section of four term math functions.

RANGE_HI: Constant value above which the range extension has switch to the high range transmitter.

RANGE_LO: Constant value below which the range extension has switch to the high range transmitter.

BIAS_IN_1: The bias value for IN_1.

GAIN_IN_1: The proportional gain (multiplier) value for IN_1.

BIAS_IN_2: The bias value for IN_2.

GAIN_IN_2: The proportional gain (multiplier) value for IN_2.

BIAS_IN_3: The bias value for IN_3.

GAIN_IN_3: The proportional gain (multiplier) value for IN_3.

COMP_HI_LIM: Determines the high limit of the compensation input.

COMP_LO_LIM: Determines the low limit of the compensation input.

ARITH_TYPE: The set of 9 arithmetic functions applied as compensation to or augmentation of the range extended input.

BAL_TIME: Specifies the time for a block value to match an input, output, or calculated value or the time for dissipation of the internal balancing bias.

BIAS: The bias value is used to calculate the output.

GAIN: The gain value is used to calculate the output.

OUT_HI_LIM: The maximum output value allowed.

OUT_LO_LIM: The minimum output value allowed.

UPDATE_EVT: This alert is generated by any changes to the static data.

BLOCK_ALM: Used for all configuration, hardware, connection failure, or system problem in the block.

BLOCK_ERR_DESC: Reports more specific details regarding some errors reported through **BLOCK_ERR**.

3.3 Input Selector Block (IS)

The Input Selector (IS) function block can be used to select the first good, maximum, minimum, or average of as many as four input values and place it at the output. The block supports signal status propagation. (There is no process alarm detection in the Input Selector function block.)

ST_REV: The revision level of the static data associated with the function block. The revision value will be incremented each time a static parameter value in the block is changed.

TAG_DESC: The user description of the intended application of the block.

STRATEGY: The strategy field can be used to identify grouping of blocks. This data is not checked or processed by the block.

ALERT_KEY: The identification number of the plant unit. This information may be used in the host for sorting alarms, etc.

MODE_BLK : The actual, target, permitted, and normal modes of the block.

- Target: The mode to “go to”
- Actual: The mode the “block is currently in”
- Permitted: Allowed modes that target may take on
- Normal: Most common mode for target

BLOCK_ERR: This parameter reflects the error status associated with the hardware or software components associated with a block. It is a bit string, so that multiple errors may be shown.

OUT: The block output value and status.

OUT_RANGE: High and low scale values, engineering units code, and number of digits to the right of the decimal point associated with **OUT**

GRANT_DENY: Options for controlling access of host computers and local control panels to operating, tuning, and alarm parameters of the block.

STATUS_OPTIONS : Allows you to select options for status handling and processing. The supported status options for the input selector block are: “Use Uncertain as Good”, “Uncertain if Man mode.”

IN_1: The block input value and status.

IN_2: The block input value and status.

IN_3: The block input value and status.

IN_4: The block input value and status.

DISABLE_1: Parameter to switch off the input from being used 0- Use, 1 - Disable.

DISABLE_2: Parameter to switch off the input from being used 0- Use, 1 - Disable.

DISABLE_3: Parameter to switch off the input from being used 0- Use, 1 - Disable.

DISABLE_4: Parameter to switch off the input from being used 0- Use, 1 - Disable.

SELECT_TYPE: Determines the selector action; First good, Minimum, Maximum, Middle, Average.

MIN_GOOD: The minimum number of inputs which are “good” is less than the value of MIN_GOOD then set the OUT status to “bad”.

SELECTED: The integer indicating the selected input number.

OP_SELECT: An operator settable parameter to force a given input to be used.

UPDATE_EVT: This alert is generated by any change to the static data.

BLOCK_ALM: The block alarm is used for all configuration, hardware, connection failure, or system problems in the block.

BLOCK_ERR_DESC: Reports more specific details regarding some errors reported through BLOCK_ERR.

3.4 Signal Characterizer Block (SC)

The Signal Characterizer (SC) function block characterizes or approximates any function that defines an input/output relationship. The function is defined by configuring as many as 21 X, Y coordinates. The block interpolates an output value for a given input value using the curve defined by the configured coordinates. Two separate analog input signals can be processed simultaneously to give two corresponding separate output values using the same defined curve.

ST_REV: The revision level of the static data associated with the function block. The revision value will be incremented in each time a static parameter value in the block is changed.

TAG_DESC: The user description of the intended application of the block.

STRATEGY: The strategy field can be used to identify grouping of blocks. This data is not checked or processed by the block.

ALERT_KEY: The identification number of the plant unit. This information may be used in the host for sorting alarms, etc.

MODE_BLK: The actual, target, permitted, and normal modes of the block.

- Target: The mode to “go to”
- Actual: The mode the “block is currently in”
- Permitted: Allowed modes that target may take on
- Normal: Most common mode for target

BLOCK_ERR: This parameter reflects the error status associated with the hardware or software components associated with a block. It is a bit string so that multiple errors may be shown.

OUT1: The block output value and status.

OUT2: The block output value and status.

X_RANGE: The display scaling of the variable corresponding to the x-axis for display. It has no effect on the block.

Y_RANGE: The display scaling of the variable corresponding to the y-axis for display. It has no effect on the block.

GRANT_DENY: Options for controlling access of host computers and local control panels to operating, tuning, and alarm parameters of the block.

IN1: The block input value and status.

IN2: The block input value and status.

SWAP_2: Changes the algorithm in such a way that IN_2 corresponds to “y” and OUT_2 to “x”.

CURVE_X : Curve input points. The “x” points of the curve are defined by an array of 21 points.

CURVE_Y: Curve input points. The “y” points of the curve are defined by an array of 21 points.

UPDATE_EVT: This alert is generated by any changes to the static data.

BLOCK_ALM: The block alarm is used for all configuration, hardware, connection failure, or system problems in the block.

BLOCK_ERR_DESC: Reports more specific details regarding some errors reported through BLOCK_ERR.

4.0 Model 706 Transmitter Configuration

Although the ECLIPSE Model 706 transmitter can be delivered pre-configured from the factory, it can also be easily reconfigured in the shop or at the installation using the local LCD/Keypad. Bench configuration provides a convenient and efficient way to set up the transmitter before going to the tank site to complete the installation.

NOTE: The transmitter can be configured without the probe. Please disregard the “No Probe” diagnostic indicator that will appear.

4.1 Configuration Information

To utilize the QuickStart menu available on the ECLIPSE Model 706, some key information is required for configuration.

Gather the information and complete the following operating parameters table before beginning configuration.

NOTES: The QuickStart menu is available for Level Only applications.

1. Refer to Section 2.6.5 for configuration menus for Interface, Volume or Flow applications.
2. These configuration steps are not necessary if the transmitter was pre-configured prior to shipment.

Display	Question	Answer
Level Units	What units of measurement will be used? (inches, millimeters, centimeters, feet or meters)	_____
Probe Model	What probe model is listed on the model information? (first three digits of probe model number)	_____
Probe Mount	Is the probe mounted NPT, BSP, or flange? (Refer to probe model.)	_____
Probe Length	What probe length is listed on the probe model information? (last three digits of the probe model number)	_____
Level Offset	The desired level reading when the liquid is at the tip of the probe. (Refer to Section 3.4 for more information.)	_____
Dielectric Range	What is the dielectric constant range of the process medium?	_____

4.2 Menu Traversal and Data Entry

The four push buttons offer various forms of functionality for navigation and data entry.

The Model 706 user interface is hierarchical in nature, best described as a tree structure. Each level in the tree contains one or more items. Items are either menu labels or parameter names.

- Menu labels are presented in all capital letters
- Parameters are capital words

4.2.1 Navigating the Menu

- ⇧ **UP** moves to the previous item in the menu branch.
- ⇩ **DOWN** moves to the next item in the menu branch.
- ⇐ **BACK** moves back one level to the previous (higher) branch item.
- ⇒ **ENTER** enters into the lower level branch or switches to the entry mode. Holding the ENTER down on any highlighted menu name or parameter will show help text for that item.

4.2.2 Data Selection

This method is used for selecting configuration data from a specific list.





- ⇧ **UP** and ⇩ **DOWN** to navigate the menu and highlight the item of interest
- ⇒ **ENTER** allows modification of that selection
- ⇧ **UP** and ⇩ **DOWN** to choose new data selection
- ⇒ **ENTER** to confirm selection

Use ⇐ **BACK** (Escape) key at any time to abort the procedure and escape to previous branch item.



4.2.3 Entering Numeric Data Using Digit Entry

This method is used to input numeric data, e.g., Probe Length or level offset.





Push button		Keystroke Action
	Up	Moves up to the next highest digit (0,1,2,3,....,9 or decimal point). If held down the digits scroll until the push button is released.
	Down	Moves up to the next lowest digit (0,1,2,3,....,9 or decimal point). If held down the digits scroll until the push button is released.
	Back	Moves the cursor to the left and deletes a digit. If the cursor is already at the leftmost position, then the screen is exited without changing the previously saved value.
	Enter	Moves the cursor to the right. If the cursor is located at a blank character position, the new value is saved.

All numeric values are left-justified, and new values are entered from left to right. A decimal point can be entered after the first digit is entered, such that .9 is entered as 0.9.

Some configuration parameters can have a negative value. In this case, the leftmost position is reserved for the sign (either "-" for a negative value, or "+" for a positive value).

4.2.4 Entering Numeric Data Using Increment/Decrement





Use this method to input the following data into parameters such as Failure Alarm Delay.

Push button		Keystroke Action
	Up	Increments the displayed value. If held down the digits scroll until the push button is released. Depending on which screen is being revised, the increment amount may increase by a factor of 10 after the value has been incremented 10 times.
	Down	Decrements the displayed value. If held down the digits scroll until the push button is released. Depending on which screen is being revised, the decrement amount may increase by a factor of 10 after the value has been decremented 10 times.
	Back	Returns to the previous menu without changing the original value, which is immediately redisplayed.
	Enter	Accepts the displayed value and returns to the previous menu.

4.2.5 Entering Character Data

This method is used for parameters requiring alphanumeric character entry, such as for entering tags, etc.

General Menu Notes:

Push button		Keystroke Action
	Up	Moves to the previous character (Z...Y...X...W). If held down, the characters scroll until the push button is released.
	Down	Moves to the next item character (A...B...C...D). If held down, the characters scroll until the push button is released.
	Back	Moves the cursor back to the left. If the cursor is already at the leftmost position, then the screen is exited without changing the original tag characters.
	Enter	Moves the cursor forward to the right. If the cursor is at the rightmost position, then the new tag is saved.

4.3 Password Protection

The ECLIPSE Model 706 transmitter has three levels of password protection to restrict access to certain portions of the menu structure that affect the operation of the system. The user password can be changed to any numerical value up to 59999. When the transmitter is programmed for password protection, a password is required whenever configuration values are changed.

User Password

The User Password allows the customer to limit access to the basic configuration parameters on the local user interface only.

The default User Password installed in the transmitter at the factory is 1. (With a password of 0, the transmitter is no longer password protected and any value in the basic user menus can be adjusted without entering a confirming password.)

NOTE: If a User Password is not known or has been misplaced, the menu item New Password in the DEVICE SETUP/ADVANCED CONFIG menu displays an encrypted value representing the present password. Contact Technical Support with this encrypted password to retrieve the original User Password.

Advanced Password

Certain portions of the menu structure that contain more advanced parameters are further protected by an Advanced Password.

This password will be provided, when necessary, by Factory technical support.

Factory Password

Calibration-related and other factory settings are further protected by a Factory Password.

4.4 Model 706 Menu: Step-By-Step Procedure

The following tables provide a complete explanation of the software menus displayed by the ECLIPSE transmitter. The menu layout is similar between the local Keypad/LCD interface, the DD, and the DTM.

Use these tables as a step-by-step guide to configure the transmitter based on the desired measurement type from the following selections:

- Level Only
- Interface & Level
- Level & Volume
- Flow

HOME SCREEN

The Home Screen consists of a “slide show” sequence of Measured Values screens which are rotated at 2-second intervals. Each Home Measured Value screen can present up to four information items:

- **Physical Device Tag**
- **Measured Value**
Label, Numerical Value, Units
- **Status**
Will be displayed as text
- **Bar Graph** (shown in %)
Bar graph is only displayed on AI_OUT screens shown in % based on XD scale configuration.

The Home Screen presentation can be customized by viewing or hiding some of these items. See DISPLAY CONFIG under the DEVICE SETUP menu in Section 2.6.5 — Configuration Menu.

At left is an example of a Home Screen for a Model 706 configured for a Level Only application.



Home Screen

MAIN MENU

Pressing any key on the Home Screen will present the Main Menu, consisting of three basic menu labels shown in all capital letters.

DEVICE SETUP

DIAGNOSTICS

MEASURED VALUES

As shown, the reverse video represents a cursor identifying the selected item, which will appear in reverse video on the LCD. The actions of the keys at this point are:



Main Menu Screen

Push button		Keystroke Action
↑	Up	No action as the cursor is already at the first item in the MAIN MENU
↓	Down	Moves the cursor to DIAGNOSTICS
←	Back	Moves back to HOME SCREEN, the level above MAIN MENU
↵	Enter	Presents the selected item, DEVICE SETUP

- NOTES:
1. Items and parameters that are shown in lower level menus will depend on the Measurement Type chosen. Those parameter not applicable to the present Measurement Type will be hidden.
 2. Holding down the Enter key when the cursor is highlighted over a parameter or menu will provide additional information about that item.

DEVICE SETUP

Choosing DEVICE SETUP from the MAIN MENU will result in an LCD presentation as shown at left.

The small down arrow shown at the right hand side of the screen is the indication that more items are available below and can be accessed by pressing the DOWN key.

Section 2.6.5 shows the entire tree menu for the Model 706 DEVICE SETUP Menu.

DIAGNOSTICS

Refer to Section 3.3.4

MEASURED VALUES

Allows the user to scroll through all of the available measured values for the measurement type chosen.



Device Setup Screen

4.5 Model 706 Configuration Menu — Device Setup

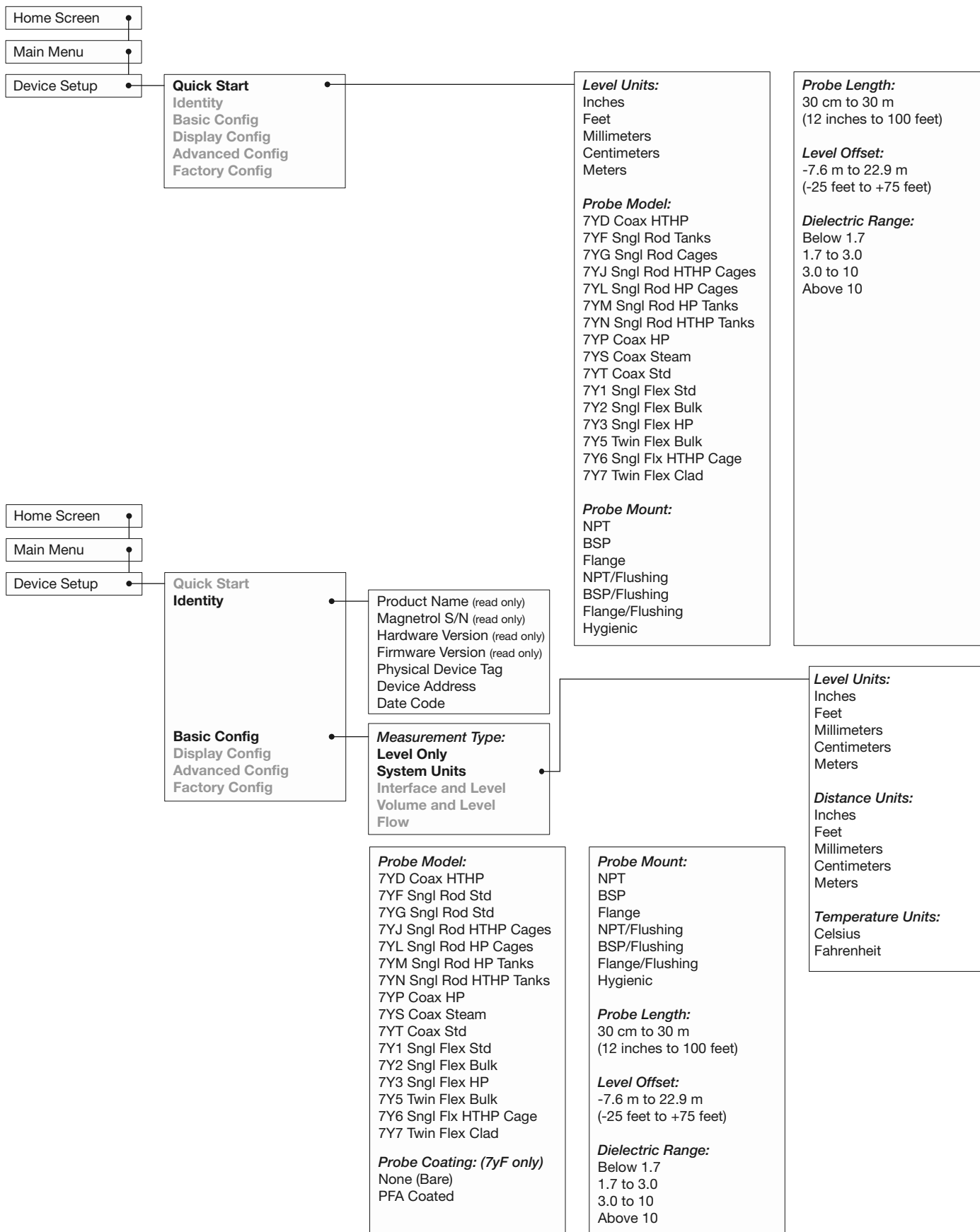

4.5 Model 706 Configuration Menu — Device Setup

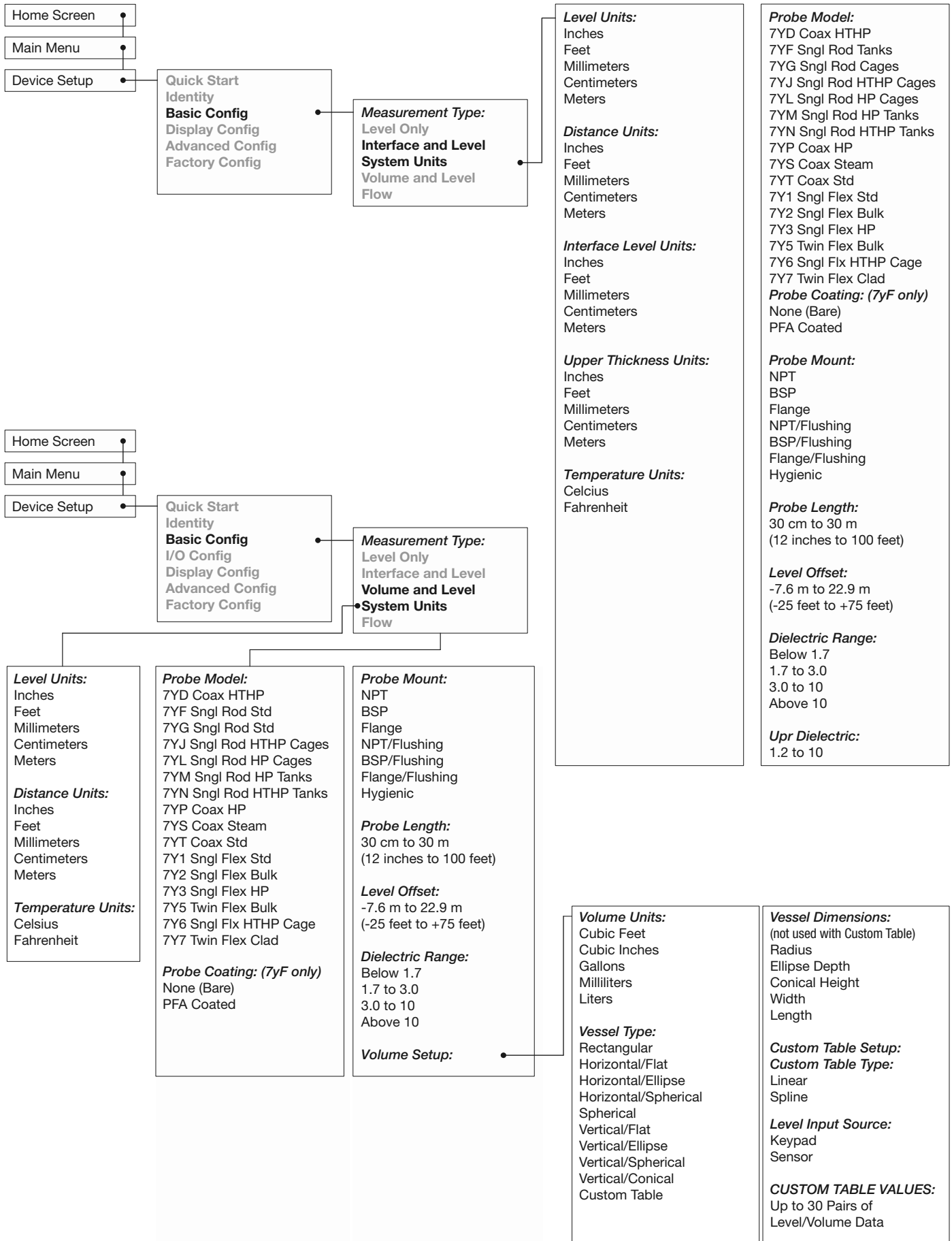

4.5 Model 706 Configuration Menu — Device Setup

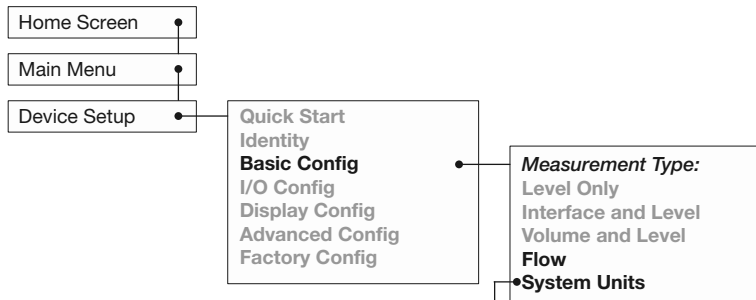

<p>Level Units: Inches Feet Millimeters Centimeters Meters</p> <p>Distance Units: Inches Feet Millimeters Centimeters Meters</p> <p>Temperature Units: Celsius Fahrenheit</p>	<p>Probe Model: 7YD Coax HTHP 7YF Sngl Rod Std 7YG Sngl Rod Std 7YJ Sngl Rod HTHP Cages 7YL Sngl Rod HP Cages 7YM Sngl Rod HP Tanks 7YN Sngl Rod HTHP Tanks 7YP Coax HP 7YS Coax Steam 7YT Coax Std 7Y1 Sngl Flex Std 7Y2 Sngl Flex Bulk 7Y3 Sngl Flex HP 7Y5 Twin Flex Bulk 7Y6 Sngl Flx HTHP Cage 7Y7 Twin Flex Clad</p> <p>Probe Mount: NPT BSP Flange NPT/Flushing BSP/Flushing Flange/Flushing Hygienic</p> <p>Probe Coating: None (Bare) PFA Coated</p> <p>Probe Length: 30 cm to 30 m (12 inches to 100 feet)</p> <p>Dielectric Range: Below 1.7 1.7 to 3.0 3.0 to 10 Above 10</p> <p>Flow Setup:</p>	<p>Flow Units: Cubic Ft/Second Cubic Ft/Minute Cubic Ft/Hour Gallons/Minute Gallons/Hour Mil Gallons/Day Liters/Second Liters/Minute Liters/Hour Cubic Meters/Hour</p> <p>Level Units: Inches Feet Millimeters Centimeters Meters</p> <p>Head Units: Inches Feet Millimeters Centimeters Meters</p> <p>Flow Element: <i>Palmer-Bowlus Flume</i> <i>Flume Channel Width:</i> 4 inches 6 inches 8 inches 10 inches 12 inches 15 inches 18 inches 21 inches 24 inches 27 inches 30 inches</p> <p>Parshall Flume <i>Flume Channel Width:</i> 1 inch 2 inches 3 inches 6 inches 9 inches 12 inches 18 inches 24 inches 36 inches 48 inches 60 inches 72 inches 96 inches 120 inches 144 inches</p>	<p>V notch Weir <i>V-notch Weir Angle:</i> 22.5° 30° 45° 60° 90° 120°</p> <p>Rect Weir with Ends 0 to 65 m (0 to 215.0 feet)</p> <p>Rect Weir w/o Ends 0 to 65 m (0 to 215.0 feet)</p> <p>Cipolletti Weir 0 to 65 m (0 to 215.0 feet)</p> <p>Generic Equation K L C n</p> <p>Custom Table <i>Custom Table Type:</i> Linear Spline</p> <p>CUSTOM TABLE VALUES: Up to 30 Pairs of Head/Flow Data</p> <p>Reference Distance: 30 cm to 30 m (11.8 inches to 100 feet)</p> <p>Maximum Head (calculated, read only)</p> <p>Maximum Flow (calculated, read only)</p> <p>Low Flow Cutoff: 0 to 9999999 cubic ft/min</p>	<p>TOTALIZER SETUP: Units: Cubic Feet Gallons Mil Gallons Liters Mil Liters Cubic Meters</p> <p>NON-RESET TOTALIZER: Units: Cubic Feet Gallons Mil Gallons Liters Mil Liters Cubic Meters</p> <p>Multiplier: 1 10 100 1,000 10,000 100,000</p> <p>Value (read only) RunTime (read only))</p> <p>RESETTABLE TOTALIZER: Mode: Disabled Enabled</p> <p>Units: Cubic Feet Gallons Mil Gallons Liters Mil Liters Cubic Meters</p> <p>Multiplier: 1 10 100 1,000 10,000 100,000</p> <p>Value (read only) RunTime (read only)</p> <p>Reset</p>
--	--	--	---	--

4.5 Model 706 Configuration Menu — Device Setup

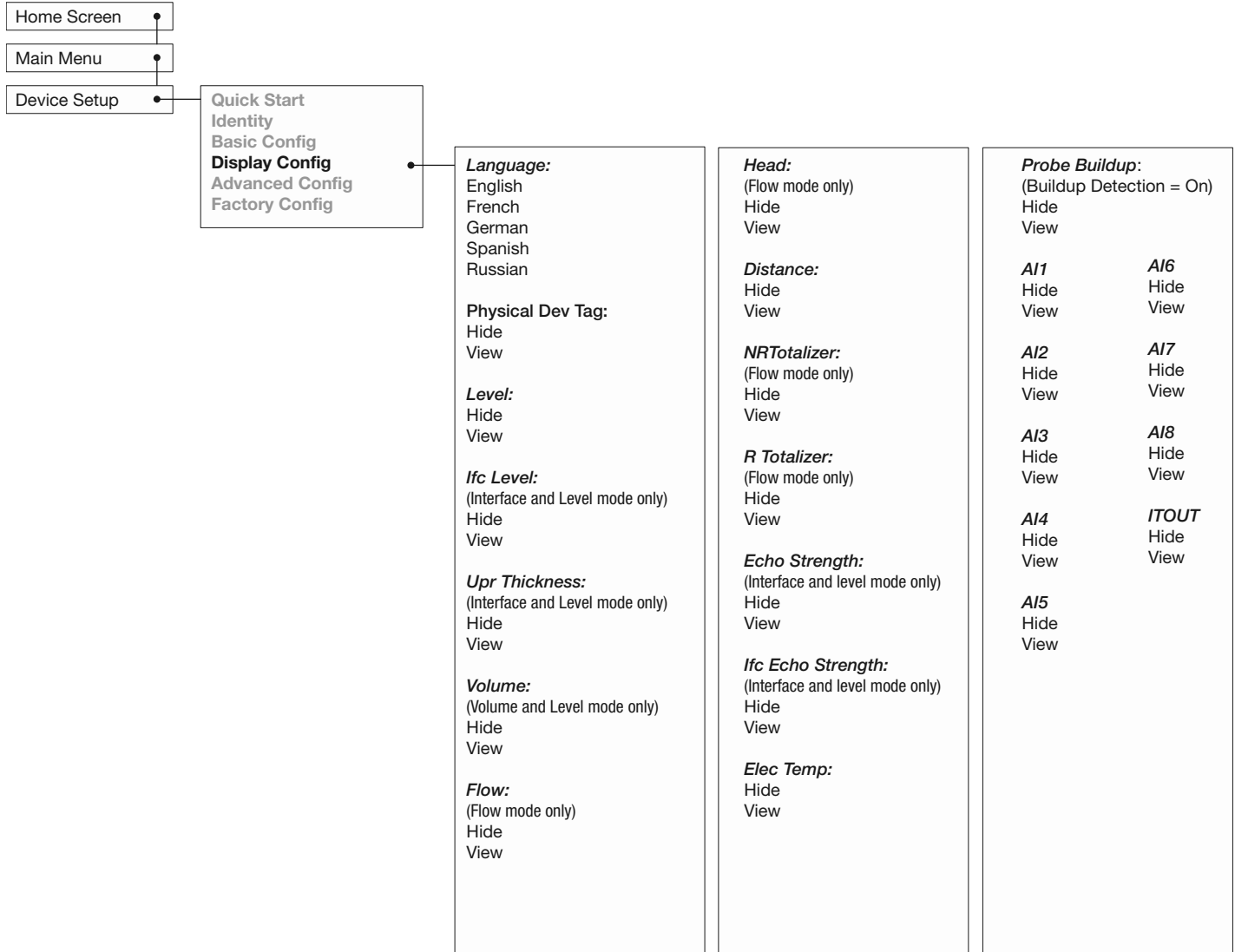

4.5 Model 706 Configuration Menu — Device Setup

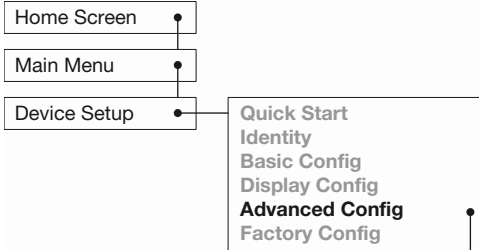

<p>Sensitivity: 0 to 100 echo strength units</p> <p>Blocking Distance: -7.5 to +100 feet (-2 m to 30 m)</p> <p>Safety Zone Alarm: Off On Latch</p> <p>Safety Zone Height: (not used when Safety Alarm is None) 2 inches to 100 feet (5 cm to 30 m)</p> <p>Reset SZ Alarm (used when Safety Alarm is Latch)</p> <p>Failure Alarm Delay: 0 to 5 seconds</p> <p>Level Trim: -0.6 m to + 0.6 m (-2.00 to + 2.00 feet)</p> <p>THRESHOLD SETTINGS</p> <p>Lvl Thresh Mode: Auto Largest (not used with Interface and Level) Fixed Value Auto Upper Sloped</p> <p>Sloped Start Value: (When Lvl Thresh Mode is Sloped)</p> <p>Lvl Thresh Value: 0 to 100 echo strength units Sloped Start Value (used when Lvl Thresh Mode is Sloped) 0 to 100 echo strength units</p>	<p>Sloped End Dist: (used when Lvl Thresh Mode is Sloped) 25 to 100 feet (7 to 30 m)</p> <p>Ifc Lvl Thresh Mode: (Interface and Level only) Auto Largest Fixed Value</p> <p>Ifc Lvl Thresh Value: (Interface and Level only) 0 to 100 echo strength units</p> <p>EoP Thresh Mode: Auto Largest Fixed Value</p> <p>EoP Thresh Value: 0 to 100 echo strength units</p> <p>ENDofPROBE ANALYSIS:</p> <p>EoP Polarity: Positive Negative</p> <p>EoP Analysis: (not used with Interface and Level) Off On</p> <p>EoP Dielectric: (not used with Interface and Level) 1.20 to 9.99</p> <p>ECHO REJECTION: View Echo Curve View Reject Curve</p> <p>REJECTION CONTROL:</p> <p>Reject Curve State: Off Disabled [Enabled]</p>	<p>Reject Curve Mode: Level Distance</p> <p>Saved Medium</p> <p>NEW REJECT CURVE: Actual Medium Save Reject Curve</p> <p>Compensation: None Auto Manual Vapor Dielectric 1.00 to 2.00</p> <p>HF Cable Length: Integral 3 feet 12 feet</p> <p>Buildup Detection: Off On</p> <p>New User Password: 0 to 59,999</p> <p>CONFIG CHANGED:</p> <p>Indicator Mode: Disabled Enabled</p> <p>Reset Config Chngd: Reset? No Yes</p> <p>Reset Parameters: No Yes</p>
---	--	---

4.5 Model 706 Configuration Menu — Device Setup

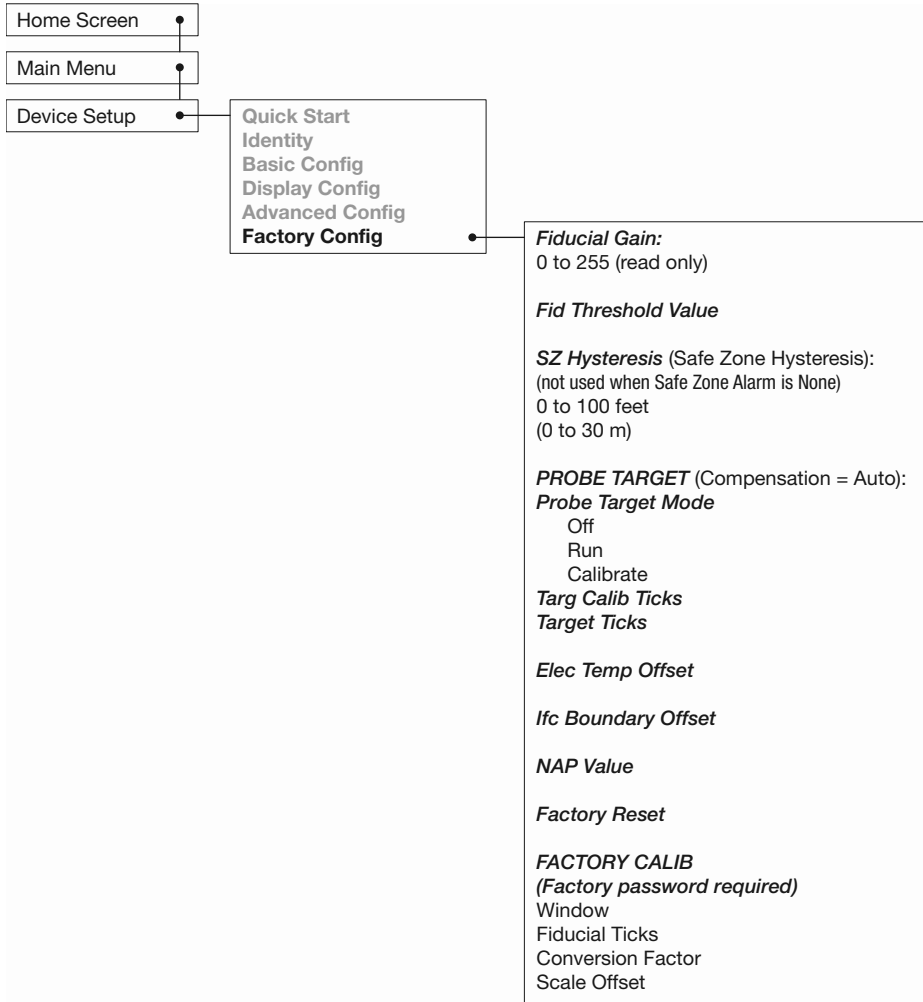

5.0 Troubleshooting and Diagnostics

The ECLIPSE Model 706 transmitter is designed and engineered for trouble-free operation over a wide range of operating conditions. The transmitter continuously runs a series of internal self-tests and displays helpful messages on the large graphic liquid crystal display (LCD) when attention is required.

The combination of these internal tests and diagnostics messages offer a valuable proactive method of troubleshooting. The device not only tells the user what wrong, but also, and more importantly, offers suggestions on how to solve the problem.

All of this information can be obtained directly from the transmitter on the LCD, remotely from the Fieldbus host system, or by utilizing PACTware and the ECLIPSE Model 706 DTM.

PACTware™ PC Program

The ECLIPSE Model 706 offers the ability to perform more advanced diagnostics such as Trending and Echo Curve analysis using a PACTware DTM. This is a powerful troubleshooting tool that can aid in the resolution of any diagnostic indicators that may appear.

5.1 Diagnostic Parameters

As mentioned above, the ECLIPSE Model 706 measurement engine runs through a series of self-tests and will detect and report fault operations. The TRANSDUCER BLOCK displays this diagnostic information in the STATUS INDICATOR parameter. Refer to Section 5.1.3 for more information on specific diagnostic indicators.

Note: Within the TRANSDUCER BLOCK, BLOCK_ERROR is not used except for indicating Out of Service (OOS).

For the first few seconds after power is applied to the Model 706 transmitter, the LEVEL_STATUS/QUALITY is “Uncertain,” the SUB_STATUS is “Initial value,” and the LIMIT attribute is shown as “Constant.”

When the Model 706 is operating properly, the LEVEL_STATUS/QUALITY is shown as “GOOD,” and the SUB_STATUS is “Non-Specific.”

While changing any transmitter parameters using the local display or through a system configuration tool (with the MODE_BLK in OOS), the output might be inaccurate because of the changing parameters. When the device is set to OOS, the TRANSDUCER BLOCK will still output level but the QUALITY will be shown as “Bad” and the SUB_STATUS is “Out of Service.”

If the Model 706 fails to find a measurable level, the TRANSDUCER BLOCK maintains the last good value as the output and flags the failure. The QUALITY is “Bad,” the SUB_STATUS is “Sensor failure” for no level, and the LIMIT attribute is “Constant.”

Refer to Section 5.2 for additional information.

5.1.1 Diagnostics (Namur NE 107)

The ECLIPSE Model 706 transmitter includes an exhaustive list of Diagnostic Indicators which follow the NAMUR NE 107 guidelines.

NAMUR is an international user association of automation technology in process industries, whose goal is to promote the interest of the process industry by pooling experiences among its member companies. In doing so, this group promotes international standards for devices, systems, and technologies.

The objective of NAMUR NE 107 was essentially to make maintenance more efficient by standardizing diagnostics information from field devices. This was initially integrated via FOUNDATION Fieldbus, but the concept applies regardless of the communication protocol.

According to the NAMUR NE107 recommendation, "Self Monitoring and Diagnosis of Field Devices," fieldbus diagnostic results should be reliable and viewed in the context of a given application. The document recommends categorizing internal diagnostics into four standard status signals:

- Failure
- Function Check
- Out of Specification
- Maintenance required

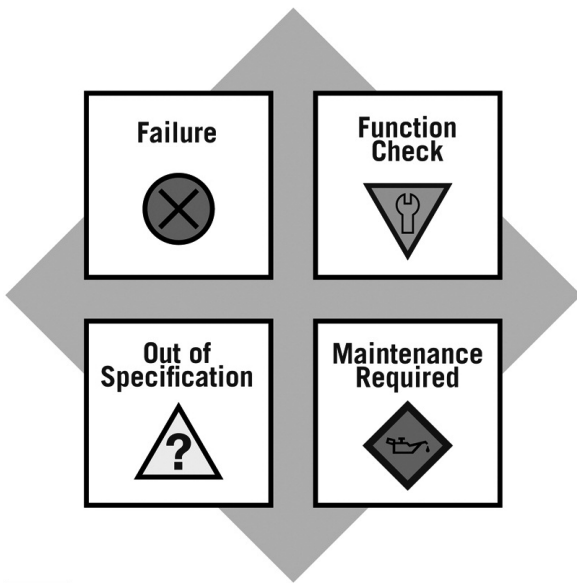

In essence, this approach ensures that the right diagnostic information is available to the right person-at the right time. In addition, it allows diagnostics to be applied, as most appropriate, for a particular plant application (such as process control engineering or asset management maintenance). Customer specific mapping of diagnostics to these categories allows for flexible configuration depending on the user's requirements.

From an external Model 706 transmitter perspective, diagnostic information includes measurement of process conditions, in addition to detection of internal device or system anomalies.

As mentioned above, the indicators can be assignable (via the DTM or host system) by the user to any (or none) of the NAMUR recommended Status Signal categories: Failure, Function Check, Out of Specification, and Maintenance Required.

The FOUNDATION fieldbus version of the Model 706 transmitter was implemented according to the Field Diagnostics Profile, which is consistent with the objectives of NE 107.

In the FOUNDATION fieldbus version, diagnostic indicators can be mapped to multiple categories, an example is shown in the diagram at left.

In this example, “Calibration Required” is mapped to both the Out of Specification and Maintenance Required status signals, and the diagnostic indicator named “High Temperature” is mapped to none of the signals.

Indicators that are mapped to the Failure category will normally result in a bad status indication.

A default mapping of all diagnostic indicators will be applied initially, and can be re-applied through use of a restart with defaults operation.

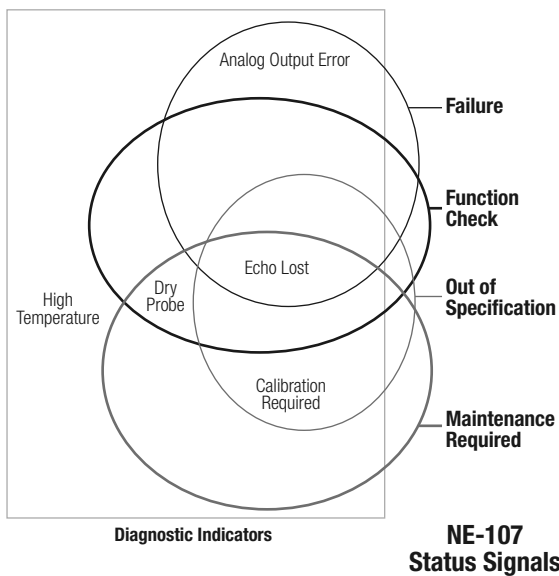

Refer to the table below for a complete listing of the Model 706 diagnostic indicators, along with their explanations, default categories, and recommended remedies.

- NOTES: 1) The remedies shown in this table can also be seen on the transmitter LCD by viewing the present status screen when the device is in a diagnostic condition.
- 2) Those indicators showing failure as the default result in an alarm condition.

5.1.2 Diagnostic Indication Simulation

The DD and DTM allow for the ability to manipulate diagnostic indicators mapped to NE-107 alarm categories in Resource Block. Intended as a means to verify the configuration of the diagnostic parameters and connected equipment, a user can manually change any indicator in the Resource Block to and from the active state.

5.1.3 Diagnostic Indicator Table

Below is a listing of the Model 706 diagnostic indicators, showing their priority, explanations and recommended remedies. (Priority 1 is highest priority.)

Priority	Indicator Name	Default Category	Explanation	Remedy (Context Sensitive Help)
1	Software Error	Failure	Unrecoverable error occurred in stored program.	Contact MAGNETROL Technical Support.
2	RAM Error	Failure	RAM (read/write) memory failing.	
3	ADC Error	Failure	Analog-to-digital converter failure.	
4	EEPROM Error	Failure	Non-volatile parameter storage failing.	
5	Analog Board Error	Failure	Unrecoverable hardware failure.	
6	Spare Indicator 1	OK	Reserved for future use.	
7	Default Parameters		Saved parameters are set to default values.	Perform complete Device Configuration.
8	No Probe	Failure	No Probe Connected.	Ensure "Model 706 Style" probe is attached. Torque HF nut. Clean gold pin on transmitter and socket on probe. Contact MAGNETROL Technical Support.
9	No Fiducial	Failure	Reference signal too weak to detect.	Torque HF nut. Clean gold pin on transmitter and socket on probe. Check settings: Fiducial Gain HF Cable Length Window Increase Fid Gain. Contact MAGNETROL Technical Support.

Priority	Indicator Name	Default Category	Explanation	Remedy
10	No Echoes	Failure	No signal detected anywhere on probe.	Check settings: Dielectric Range Sensitivity EoP Thresh Value Increase Sensitivity. Lower EoP Thresh. View Echo Curve.
11	Echo Lost	Failure	Signal from upper liquid too weak to detect.	Check settings: Upper Dielectric, Blocking Distance, Sensitivity Ensure Upr Level is below blocking distance. View Echo Curve.
12	Spare Indicator 2	OK	Reserved for future use.	
13	EoP Above ProbeEnd	Failure	End of Probe appears above Probe Length	Check settings: Probe Length Decrease Sensitivity Increase Blocking Distance View Echo Curve.
14	Lvl Below ProbeEnd	Failure	Level signal appears beyond Probe Length. (Possible water bottom situation)	Check settings: Probe Model, Probe Length, Level Threshold = Fixed Increase Sensitivity View Echo Curve.
15	EoP Below ProbeEnd	Failure	End of Probe appears beyond Probe Length.	Check settings: Probe Length Dielectric Range Sensitivity View Echo Curve.
16	Safety Zone Alarm	Failure	Risk of echo loss if liquid rises above Blocking Distance.	Ensure that liquid cannot reach Blocking Distance.
17	High Volume Alarm	Failure	Volume calculated from Level reading exceeds capacity of vessel or custom table.	Check settings: Vessel Dimensions, Custom Table entries
18	High Flow Alarm	Failure	Flow calculated from Distance reading exceeds capacity of flow element or custom table.	Check settings: Flow Element Reference Distance Gen Eqn Factors Custom Table entries
19	Spare Indicator 3	OK	Reserved for future use	
20	Initializing	Function Check	Distance measurement is inaccurate while internal filters are settling.	Standard start-up message. Wait for up to 10 seconds.
21	TB Config Changed	Function Check	A transducer block parameter has been modified from the User Interface.	If desired, reset Config Changed indicator in ADVANCED CONFIG menu.

5.1.3 Diagnostic Indicator Table

Priority	Indicator Name	Default Category	Explanation	Remedy
22	Spare Indicator 4	OK	Reserved for future use.	
23	Spare Indicator 5	OK	Reserved for future use.	
24	Spare Indicator 6	OK	Reserved for future use.	
25	Ramp Interval Error	Out of Spec	Internal signal timing out of limits causing inaccurate distance measurement.	Check accuracy of Level reading. Replace transmitter electronics. Contact MAGNETROL Technical Support.
26	High Elec Temp	Out of Spec	Electronics too hot. May compromise level measurement or damage instrument.	Shield transmitter from heat source or increase air circulation. Locate transmitter remotely in a cooler area.
27	Low Elec Temp	Out of Spec	Electronics too cold. May compromise level measurement or damage instrument.	Insulate transmitter. Locate transmitter remotely in a cooler area.
28	Calibration Req'd	Out of Spec	Factory calibration has been lost. Measurement accuracy may be diminished.	Return transmitter to factory for recalibration.
29	Echo Reject Invalid	Out of Spec	Echo Rejection inoperative. May report erroneous Level readings. Upr Echo may be lost near top of probe.	Save a fresh Echo Rejection Curve.
30	Spare Indicator 7	OK	Reserved for future use.	
31	Inferred Level	Out of Spec	Distance measurement calculated indirectly from probe elongation. Level reading is only approximate.	Verify Level reading. If incorrect, compare Dielectric Range against EoP Dielectric reading.
32	Totalizer Data Lost	Out of Spec	Non-volatile Totalizer Data storage failing.	Contact MAGNETROL Technical Support.
33	No Probe Target	Out of Spec	Not actively compensating	Check settings: Probe Model Sensitivity
34	Dry Probe	OK	No liquid is contacting probe. Level at unknown distance beyond probe.	If unexpected, verify proper probe length for application.
35	Spare Indicator 8	OK	Reserved for future use.	
36	Low Echo Strength	Maintenance Required	Risk of Echo Lost due to weak signal.	Check settings: Dielectric Range Sensitivity View Echo Curve.
37	Low Ifc Echo Str	Maintenance Required	Risk of Interface Echo Lost due to weak signal.	Check settings: Dielectric Range Sensitivity View Echo Curve.
38	Spare Indicator 9	OK	Reserved for future use.	
39	Spare Indicator 10	OK	Reserved for future use.	
40	Sequence Record	OK	A Sequence Record number has been stored in Event Log.	If desired, report Sequence Record number to factory.

The ECLIPSE Model 706 offers the ability to do Trending and Echo Curve analysis via the local graphical LCD or by using PACTware and the Model 706 DTM. The Model 706 DTM is an advanced troubleshooting tool that can aid in the resolution of some of the Diagnostic Indicators shown above.

5.1.4 Diagnostic Help

Selecting DIAGNOSTICS from the MAIN MENU presents a list of five ITEMS from the top level of the DIAGNOSTICS tree.

When Present Status is highlighted, the highest MAGNETROL priority active diagnostic indicator (numerically lowest in Table 5.1.3) is displayed on the bottom LCD line as shown above. Pressing the ENTER key moves the active diagnostic indicator to the top line outdented and presents in the lower area of the LCD a brief explanation of and possible remedies for the indicated condition. A blank line separates the explanation from the remedies. Additional active diagnostic indicators, if any, appear with their explanations in descending priority order. Each additional active indicator name-explanation pair is separated by a blank line from the one above.

If the explanation and remedy text (and additional name-explanation pairs) exceeds the available space, a ⏴ appears in the rightmost column of the last line indicating more text below. In this situation, the DOWN key scrolls the text up. Similarly, while text exists above the upper line of the text field, a ⏵ appears in the rightmost column of the top (text) line. In this situation, the UP key scrolls the text down. Otherwise the DOWN and UP keys are inoperative. In all cases the ENT or BACK key reverts to the previous screen.

When the transmitter is operating normally and the highlight cursor is positioned on Present Status, the bottom LCD line displays “OK” because no diagnostic indicators are active.

EVENT HISTORY – This menu displays the parameters related to diagnostic event logging.

ADVANCED DIAGNOSTICS – This menu displays parameters related to some of the advanced diagnostics available within the Model 706.

INTERNAL VALUES – Displays read-only internal parameters.

ELEC TEMPERATURES – Displays temperature information as measured in the potted module in degrees F or C.

ECHO CURVES – This menu allows the user to display the live Echo Curve and Echo Rejection on the LCD.



ECHO HISTORY SETUP – The Model 706 contains the unique and powerful feature that allows waveforms to be automatically captured based on Diagnostic Events, Time or both. This menu contains those parameters that configure that feature.

Eleven (11) waveforms can be saved directly into the transmitter.

- Nine (9) Troubleshooting Curves
- One (1) Echo Rejection Curve
- One (1) Reference Curve

TREND DATA – A 15-minute trend of the PV can be displayed on the LCD.

5.2 Diagnostic Parameters

Each detected diagnostic condition potentially affects the status of one or more of the Transducer Block output parameters.

The Process Variable Status is described by three characteristics—Quality, Sub-status and Limit.

The following table assigns the proposed values of these characteristics, in order of decreasing priority, for each of the diagnostic conditions and/or device configurations.

- NOTES:
- 1) Only the highest priority status will be indicated for a given process variable.
 - 2) If a process variable is not listed for a given diagnostic condition and/or device configuration, the status of that process variable is not affected and will be shown as Good::Non-specific: Not limited

Diagnostic/Condition	Process Variables	Quality	Sub-status	Limit
Level TB → OOS	Level Distance Interface Level Upper Thickness Echo Strength Ifc Echo Strength Probe Buildup Elec Temperature	Bad	Out of Service	Not Limited
Vol TB → OOS	Volume	Bad	Out of Service	Not Limited
Flow TB → OOS	Flow Head Nr Toalizer R Toalizer	Bad	Out of Service	Not Limited
Analog Board Error	All PVs except Elec Temperature	Bad	Sensor Failure	Constant limited
No Probe	All PVs except Elec Temperature	Bad	Sensor Failure	Constant limited

Diagnostic/Condition	Process Variables	Quality	Sub-status	Limit
No Echoes	All PVs except Elec Temperature	Bad	Sensor Failure	Constant limited
Lvl Below ProbeEnd	All PVs except Elec Temperature	Bad	Sensor Failure	Constant limited
EoP Below ProbeEnd	All PVs except Elec Temperature	Bad	Sensor Failure	Constant limited
Software Error	All PVs	Bad	Device Failure	Constant limited
RAM Error	All PVs	Bad	Device Failure	Constant limited
ADC Failure	All PVs	Bad	Device Failure	Constant limited
EEPROM Error	All PVs	Bad	Device Failure	Constant limited
No Fiducial	All PVs except Elec Temperature	Bad	Device Failure	Constant limited
Echo Lost	All PVs except Elec Temperature	Bad	Device Failure	Constant limited
Inferred Level	Echo Strength Ifc Level Upper Thickness Ifc Echo Strength Probe Buildup	Bad	Device Failure	Constant limited
Totalizer Data Lost	NR Totalizer R Totalizer	Bad	Config Error	Not limited
Default Parameters	All PVs	Bad	Config Error	Not limited
EoP Above ProbeEnd	All PVs except Elec Temperature	Bad	Config Error	Not limited
Buildup Detection disabled	Probe Buildup	Bad	Config Error	Constant limited
MeasType != Interface & Level	Ifc Level Upper Thickness Ifc Echo Strength	Bad	Config Error	Constant limited
MeasType != Volume & Level	Volume	Bad	Config Error	Constant limited
MeasType != Flow	Flow Head NR Totalizer R Totalizer	Bad	Config Error	Constant limited
MeasType = Flow and R Totalizer Mode off	R Totalizer	Bad	Config Error	Constant limited
High Volume Alarm	Volume	Bad	Config Error	High limited
High Flow Alarm	Flow Head	Bad	Non-Specific	High limited
Safety Zone Alarm	Level Ifc Level Upper Thick Distance Volume Head Flow	Bad	Non-Specific	Not limited

Diagnostic/Condition	Process Variables	Quality	Sub-status	Limit
Initializing	All PVs except Elec Temperature	Uncertain	Initial Value	Constant limited
Dry Probe	Distance	Good	Non-Specific	High limited
	Level Ifc Level Upper Thickness Volume Flow Head	Good	Non-Specific	Low limited
	NR Totalizer R Totalizer	Good	Non-Specific	Constant limited
TB Config Changed	All PVs	Good	Non-Specific	Not limited
Ramp Interval Error	All PVs	Good	Non-Specific	Not limited
High Elec Temp	All PVs	Good	Non-Specific	Not limited
Low Elec Temp	All PVs	Good	Non-Specific	Not limited
Calibration Req'd	All PVs	Good	Non-Specific	Not limited
Echo Reject Invalid	All PVs	Good	Non-Specific	Not limited
No Probe Target	All PVs	Good	Non-Specific	Not limited
Low Echo Strength	All PVs	Good	Non-Specific	Not limited
Low Ifc Echo Strength	All PVs	Good	Non-Specific	Not limited
Sequence Record	All PVs	Good	Non-Specific	Not limited

5.3 FOUNDATION fieldbus Segment Checklist

There can be several reasons for a FOUNDATION fieldbus™ installation to be in a faulty condition. In order to ensure that communication can be established, the following requirements must be met.

- Device supply voltage must be higher than 9 VDC with a maximum of 32 VDC.
- Total current draw of a given segment cannot exceed the rating shown on the power conditioner and/or barrier.
- Device polarity must be correct.
- Two 100 Ω, 1 μF terminators must be connected to the network—one at each end of the segment.
- Cable length plus spur length must not exceed the following values:

Number of Spurs	1 Device	2 Devices	3 Devices	4 Devices
25–32	—	—	—	—
19–24	30 m (100 ft.)	—	—	—
15–18	60 m (200 ft.)	30 m (100 ft.)	—	—
13–14	90 m (300 ft.)	60 m (200 ft.)	30 m (100 ft.)	—
1–12	120 m (400 ft.)	90 m (300 ft.)	60 m (200 ft.)	30 m (100 ft.)

Pair	Shield	Twisted	Size	Length	Type
Single	Yes	Yes	AWG 18 (0.8 mm ²)	1900 m (6,200 ft.)	A
Multi	Yes	Yes	AWG 22 (0.32 mm ²)	1200 m (3,900 ft.)	B
Multi	No	Yes	AWG 26 (0.13 mm ²)	400 m (1,300 ft.)	C
Multi	Yes	No	AWG 16 (1.25 mm ²)	200 m (650 ft.)	D

- The cable shield is to be hard grounded only at one point close to the DCS. In addition, the cable shield can be capacitively grounded in multiple places to improve EMC protection.
- Ensure all devices are on the “live list,” and the schedule has been downloaded.
- Ensure that the Resource Block, then the Transducer Block, and lastly the Function Block(s) are in “Auto” mode rather than Out of Service (OOS).

If all of these requirements are met, stable communication should be established.

Appendix A

Level (and Interface) Transducer Block Table

Item	Parameter Name	Parameter Label
0	BLOCK_STRUCTURE	BLOCK STRUCT
1	ST_REV	Static Revision
2	TAG_DESC	Tag Description
3	STRATEGY	Strategy
4	ALERT_KEY	Alert Key
5	MODE_BLK	Block Mode
6	BLOCK_ERR	Block Error
7	UPDATE_EVT	Update Event
8	BLOCK_ALM	Block Alarm
9	TRANSDUCER_DIRECTORY	Transducer Directory
10	TRANSDUCER_TYPE	Transducer Type
11	XD_ERROR	Transducer Error
12	COLLECTION_DIRECTORY	Collection Directory
13	MEASUREMENT_TYPE	Measurement Type
14	LEVEL	Level
15	LEVEL_UNIT	Level Unit
16	DISTANCE	Distance
17	DISTANCE_UNIT	Distance Unit
18	PROBE_MODEL	Probe Model
19	PROBE_COATING	Probe Coating
20	PROBE_MOUNT	Probe Mount
21	PROBE_LENGTH	Probe Length
22	PROBE_LEVEL_OFFSET	Level Offset
23	DIELECTRIC_RANGE	Dielectric Range
24	SENSITIVITY	Sensitivity
25	BLOCKING_DISTANCE	Blocking Distance
26	SAFETY_ZONE_MODE	Safety Zone Mode
27	SAFETY_ZONE_HEIGHT	Safety Zone Height
28	RESET_SAFETY_ZONE_LATCH	Reset SZ Latch
29	ALARM_DELAY	Failure Alarm Delay
30	LEVEL_TRIM	Level Trim
31	LEVEL_THRESHOLD_MODE	Level Threshold Mode
32	LEVEL_THRESHOLD_VALUE	Level Threshold Value
33	SLOPED_START_VALUE	Sloped Start Value
34	SLOPED_END_DISTANCE	Sloped End Distance

35	EOP_THRESHOLD_MODE	EoP Threshold Mode
36	EOP_THRESHOLD_VALUE	EoP Threshold Value
37	INTERFACE_LEVEL	Interface Level
38	INTERFACE_LEVEL_UNIT	Interface Level Unit
39	UPPER_THICKNESS	Upper Thickness
40	UPPER_THICKNESS_UNIT	Upper Thickness Unit
41	UPPER_LIQUID_DIELECTRIC	Upper Dielectric
42	IFC_LEVEL_THRESH_MODE	Ifc Level Thresh Mode
43	IFC_LEVEL_THRESH_VALUE	Ifc Level Thresh Value
44	REJECT_CURVE_STATE	Reject Curve State
45	REJECT_CURVE_MODE	Reject Curve Mode
46	SAVED_MEDIUM_LOCATION	Saved Media Location
47	NEW_MEDIUM_LOCATION	New Media Location
48	END_OF_PROBE_ANALYSIS	End of Probe Analysis
49	EOP_POLARITY	EoP Polarity
50	EOP_DIELECTRIC	EoP Dielectric
51	COMPENSATION_MODE	Compensation Mode
52	VAPOR_DIELECTRIC	Vapor Dielectric
53	HF_CABLE_LENGTH	HF Cable Length
54	BUILDUP_DETECTION	Buildup Detection
55	PARAMETER_RESET	Parameter Reset
56	FIDUCIAL_TICKS	Fiducial Ticks
57	FIDUCIAL_STRENGTH	Fiducial Strength
58	LEVEL_TICKS	Level Ticks
59	ECHO_STRENGTH	Echo Strength
60	INTERFACE_TICKS	Interface Ticks
61	IFC_ECHO_STRENGTH	Ifc Echo Strength
62	IFC_MEDIUM_BOUNDARY	Ifc Medium Boundary
63	INTERFACE_MEDIUM	Interface Medium
64	TARGET_TICKS	Target Ticks
65	TARGET_ECHO_STRENGTH	Target Echo Strength
66	VAPOR_MEASURED_DIELECTRIC	Vapor Measured Dielectric
67	EOP_TICKS	EoP Ticks
68	EOP_ECHO_STRENGTH	EoP Echo Strength
69	EOP_DISTANCE	EoP Distance
70	EOP_MEASURED_DIELECTRIC	EoP Measured Dielectric
71	ELECTRONICS_TEMPERATURE	Electronics Temp
72	TEMPERATURE_UNIT	Temperature Unit

73	MAX_ELECTRONICS_TEMP	Max Elec Temp
74	MIN_ELECTRONICS_TEMP	Min Elec Temp
75	RESET_ELECTRONICS_TEMPS	Reset Electronic Temps
76	PROBE_BUILDUP	Probe Buildup
77	PROBE_BUILDUP_UNIT	Probe Buildup Unit
78	BUILUP_LOCATION	Buildup Location
79	BUILDUP_RATE	Buildup Rate
80	CHECK_BUILDUP_REQUEST	Check Buildup
81	ENTER_PASSWORD	Enter Password
82	FIDUCIAL_GAIN	Fidicial Gain
83	FID_THRESHOLD_VALUE	Fid Threshold Value
84	SAFETY_ZONE_HYSTERESIS	SZ Hysteresis
85	ELEC_TEMP_OFFSET	Elec Temp Offset
86	IFC_BOUNDARY_OFFSET	Ifc Boundary Offset
87	NAP_VALUE	NAP Value
88	FACTORY_RESET	Factory Reset
89	PROBE_TARGET_MODE	Probe Target Mode
90	TARGET_CALIB_TICKS	Target Calib Ticks
91	WINDOW_GWR	Window
92	CONVERSION_FACTOR	Conversion Factor
93	SCALE_OFFSET	Scale Offset
94	M7YK_SCALE_OFFSET	7XK Scale Offset
95	FACTORY_PARAMETER_1	Factory Parameter 1
96	FACTORY_PARAMETER_2	Factory Parameter 2
97	FACTORY_PARAMETER_3	Factory Parameter 3
98	FACTORY_PARAMETER_4	Factory Parameter 4
99	MAGNETROL_SERIAL_NUMBER	Magnetrol S/N
100	DATE_CODE	Date Code
101	CONFIG_CHANGED_MODE	TB Config Chgd Mode
102	RESET_CONFIG_CHANGED	Reset Config Changed
103	USER_PASSWORD	New User Password
104	LOCAL_DISP_MEAS_VALUES	Local Disp Meas Values
105	LOCAL_DISP_LANGUAGE	Local Disp Language
106	LOCAL_DISP_PHYS_DEV_TAG	Local Disp Phys Dev Tag
107	FIRMWARE_VERSION	Firmware Version
108	HARDWARE_VERSION	Hardware Version
109	PRESENT_STATUS	Present Status
110	STATUS_INDICATORS_1	Status Indicators

111	STATUS_INDICATORS_2	Status Indicators
112	STATUS_INDICATORS_3	Status Indicators
113	STATUS_INDICATORS_4	Status Indicators
114	STATUS_INDICATORS_5	Status Indicators
115	STATUS_INDICATORS_6	Status Indicators
116	TREND_LEVEL_VALUE	Level
117	TREND_DISTANCE_VALUE	Distance
118	TREND_IFC_LEVEL_VALUE	Interface Level
119	TREND_UPPER_THICK_VALUE	Upper Thickness
120	TREND_ECHO_STR_VALUE	Echo Strength
121	TREND_IFC_ECHO_STR_VALUE	Ifc Echo Strength
122	DEVICE_CLOCK	Device Clock
123	DEVICE_RUN_TIME	Run Time
124	HISTORY_CONTROL	History Control
125	HISTORY_CAPTURE_TIME	History Capture Time
126	HIST_ENTRY1	Event History 1
127	HIST_ENTRY2	Event History 2
128	HIST_ENTRY3	Event History 3
129	HIST_ENTRY4	Event History 4
130	HIST_ENTRY5	Event History 5
131	HIST_ENTRY6	Event History 6
132	HIST_ENTRY7	Event History 7
133	HIST_ENTRY8	Event History 8
134	HIST_ENTRY9	Event History 9
135	HIST_ENTRY10	Event History 10
136	RESET_HISTORY	Reset History
137	ECHO_HIST_TRIGGER_MODE	Echo Hist Trigger Mode
138	ECHO_HIST_TIME_TRIGGER	Echo Hist Time Trigger
139	ECHO_HIST_EVENTS_TRIGGER	Echo Hist Events Trigger
140	ECHO_REJECTION_LOG	Echo Rejection
141	ECHO_REFERENCE_LOG	Echo Reference
142	ECHO_HISTORY_LOG1	Echo History 1
143	ECHO_HISTORY_LOG2	Echo History 2
144	ECHO_HISTORY_LOG3	Echo History 3
145	ECHO_HISTORY_LOG4	Echo History 4
146	ECHO_HISTORY_LOG5	Echo History 5
147	ECHO_HISTORY_LOG6	Echo History 6
148	ECHO_HISTORY_LOG7	Echo History 7

149	ECHO_HISTORY_LOG8	Echo History 8
150	ECHO_HISTORY_LOG9	Echo History 9
151	DELETE_ECHO_HISTORY	Delete Echo History
152	SAVE_ECHO_CURVE	Save Echo Curve
153	VIEW_ECHO_CURVE	View Echo Curve
154	WAVEFORM_SUMMARY	Waveform Summary
155	ECHO_CURVE_DATA	Echo Curve Data
156	ECHO_DATA_INDEX	Echo Data Index
157	DATA_LOG_SETUP	Data Log Setup
158	DATA_LOG_SUMM_READ_REQ	Log Summary Read Req
159	DATA_LOG_SUMMARY	Data Log Summary
160	DATA_LOG_INDEX	Data Log Index
161	DATA_LOG_RECORDS	Log Data
162	PD_TAG_APPL_IMAGE	PD Tag

Volume Transducer Block Table

Item	Parameter Name	Parameter Label
0	BLOCK_STRUCTURE	BLOCK STRUCT
1	ST_REV	Static Revision
2	TAG_DESC	Tag Description
3	STRATEGY	Strategy
4	ALERT_KEY	Alert Key
5	MODE_BLK	Block Mode
6	BLOCK_ERR	Block Error
7	UPDATE_EVT	Update Event
8	BLOCK_ALM	Block Alarm
9	TRANSDUCER_DIRECTORY	Transducer Directory
10	TRANSDUCER_TYPE	Transducer Type
11	XD_ERROR	Transducer Error
12	COLLECTION_DIRECTORY	Collection Directory
13	MEAS_TYPE	Measurement Type
14	VOLUME	Volume
15	VOLUME_UNIT	Volume Unit
16	LEVEL_VALUE	Level
17	LEVEL_UNIT	Level Unit
18	VESSEL_TYPE	Vessel Type
19	VESSEL_RADIUS	Vessel Radius
20	VESSEL_ELLIPSE_DEPTH	Vessel Ellipse Depth

21	VESSEL_CONICAL_HEIGHT	Vessel Conical Height
22	VESSEL_WIDTH	Vessel Width
23	VESSEL_LENGTH	Vessel Length
24	VOLUME_TABLE_TYPE	Volume Table Type
25	LEVEL_INPUT_SOURCE	Level Input Source
26	VOLUME_TABLE_LENGTH	Volume Table Length
27	VOLUME_TABLE_PT_01	Volume Table Pt 01
28	VOLUME_TABLE_PT_02	Volume Table Pt 02
29	VOLUME_TABLE_PT_03	Volume Table Pt 03
30	VOLUME_TABLE_PT_04	Volume Table Pt 04
31	VOLUME_TABLE_PT_05	Volume Table Pt 05
32	VOLUME_TABLE_PT_06	Volume Table Pt 06
33	VOLUME_TABLE_PT_07	Volume Table Pt 07
34	VOLUME_TABLE_PT_08	Volume Table Pt 08
35	VOLUME_TABLE_PT_09	Volume Table Pt 09
36	VOLUME_TABLE_PT_10	Volume Table Pt 10
37	VOLUME_TABLE_PT_11	Volume Table Pt 11
38	VOLUME_TABLE_PT_12	Volume Table Pt 12
39	VOLUME_TABLE_PT_13	Volume Table Pt 13
40	VOLUME_TABLE_PT_14	Volume Table Pt 14
41	VOLUME_TABLE_PT_15	Volume Table Pt 15
42	VOLUME_TABLE_PT_16	Volume Table Pt 16
43	VOLUME_TABLE_PT_17	Volume Table Pt 17
44	VOLUME_TABLE_PT_18	Volume Table Pt 18
45	VOLUME_TABLE_PT_19	Volume Table Pt 19
46	VOLUME_TABLE_PT_20	Volume Table Pt 20
47	VOLUME_TABLE_PT_21	Volume Table Pt 21
48	VOLUME_TABLE_PT_22	Volume Table Pt 22
49	VOLUME_TABLE_PT_23	Volume Table Pt 23
50	VOLUME_TABLE_PT_24	Volume Table Pt 24
51	VOLUME_TABLE_PT_25	Volume Table Pt 25
52	VOLUME_TABLE_PT_26	Volume Table Pt 26
53	VOLUME_TABLE_PT_27	Volume Table Pt 27
54	VOLUME_TABLE_PT_28	Volume Table Pt 28
55	VOLUME_TABLE_PT_29	Volume Table Pt 29
56	VOLUME_TABLE_PT_30	Volume Table Pt 30
57	VOLUME_HIGH_LIMIT	Volume High Limit
58	LEVEL_LOW_LIMIT	Level Low Limit

59	LEVEL_HIGH_LIMIT	Level High Limit
60	ENTER_PASSWORD	Enter Password
61	PRESENT_STATUS	Present Status
62	STATUS_INDICATORS_1	Status Indicators
63	STATUS_INDICATORS_2	Status Indicators
64	STATUS_INDICATORS_3	Status Indicators
65	STATUS_INDICATORS_4	Status Indicators
66	STATUS_INDICATORS_5	Status Indicators
67	STATUS_INDICATORS_6	Status Indicators
68	TREND_VOLUME_VALUE	Volume

Flow Transducer Block Table

Item	Parameter Name	Parameter Label
0	BLOCK_STRUCTURE	BLOCK STRUCT
1	ST_REV	Static Revision
2	TAG_DESC	Tag Description
3	STRATEGY	Strategy
4	ALERT_KEY	Alert Key
5	MODE_BLK	Block Mode
6	BLOCK_ERR	Block Error
7	UPDATE_EVT	Update Event
8	BLOCK_ALM	Block alarm
9	TRANSDUCER_DIRECTORY	Transducer Directory
10	TRANSDUCER_TYPE	Transducer Type
11	XD_ERROR	Transducer Error
12	COLLECTION_DIRECTORY	Collection Directory
13	MEAS_TYPE	Measurement Type
14	FLOW	Flow
15	FLOW_UNIT	Flow Unit
16	HEAD	Head
17	HEAD_UNIT	Head Unit
18	DISTANCE_VALUE	Distance
19	DISTANCE_UNIT	Distance Unit
20	NR_TOTALIZER_MULTIPLIER	NR Totalizer Multiplier
21	NR_TOTALIZER	NR Totalizer
22	NR_TOTALIZER_UNIT	NR Totalizer Unit
23	NR_TOTALIZER_TIME	NR Totalizer Time

24	R_TOTALIZER_MODE	R Totalizer Mode
25	R_TOTALIZER_MULTIPLIER	R Totalizer Multiplier
26	R_TOTALIZER	R Totalizer
27	R_TOTALIZER_UNIT	R Totalizer Unit
28	R_TOTALIZER_TIME	R Totalizer Time
29	RESET_R_TOTALIZER	Reset R Totalizer
30	REFERENCE_DISTANCE	Reference Distance
31	MAXIMUM_HEAD	Maximum Head
32	MAXIMUM_FLOW	Maximum Flow
33	LOW_FLOW_CUTOFF	Low Flow Cutoff
34	FLOW_ELEMENT	Flow Element
35	PALMER_BOWL_FLUME_WIDTH	Palmer Bowl Flume Width
36	PARSHALL_FLUME_WIDTH	Parshall Flume Width
37	V_NOTCH_WEIR_ANGLE	V Notch Weir Angle
38	WEIR_CREAST_LENGTH	Weir Crest Length
39	GENERIC_EQN_K_FACTOR	Generic Eqn K Factor
40	GENERIC_EQN_L_FACTOR	Generic Eqn L Factor
41	GENERIC_EQN_C_FACTOR	Generic Eqn C Factor
42	GENERIC_EQN_N_FACTOR	Generic Eqn n Factor
43	FLOW_TABLE_TYPE	Flow Table Type
44	FLOW_TABLE_LENGTH	Flow Table Length
45	FLOW_TABLE_PT_01	Flow Table Pt 01
46	FLOW_TABLE_PT_02	Flow Table Pt 02
47	FLOW_TABLE_PT_03	Flow Table Pt 03
48	FLOW_TABLE_PT_04	Flow Table Pt 04
49	FLOW_TABLE_PT_05	Flow Table Pt 05
50	FLOW_TABLE_PT_06	Flow Table Pt 06
51	FLOW_TABLE_PT_07	Flow Table Pt 07
52	FLOW_TABLE_PT_08	Flow Table Pt 08
53	FLOW_TABLE_PT_09	Flow Table Pt 09
54	FLOW_TABLE_PT_10	Flow Table Pt 10
55	FLOW_TABLE_PT_11	Flow Table Pt 11
56	FLOW_TABLE_PT_12	Flow Table Pt 12
57	FLOW_TABLE_PT_13	Flow Table Pt 13
58	FLOW_TABLE_PT_14	Flow Table Pt 14
59	FLOW_TABLE_PT_15	Flow Table Pt 15
60	FLOW_TABLE_PT_16	Flow Table Pt 16
61	FLOW_TABLE_PT_17	Flow Table Pt 17

62	FLOW_TABLE_PT_18	Flow Table Pt 18
63	FLOW_TABLE_PT_19	Flow Table Pt 19
64	FLOW_TABLE_PT_20	Flow Table Pt 20
65	FLOW_TABLE_PT_21	Flow Table Pt 21
66	FLOW_TABLE_PT_22	Flow Table Pt 22
67	FLOW_TABLE_PT_23	Flow Table Pt 23
68	FLOW_TABLE_PT_24	Flow Table Pt 24
69	FLOW_TABLE_PT_25	Flow Table Pt 25
70	FLOW_TABLE_PT_26	Flow Table Pt 26
71	FLOW_TABLE_PT_27	Flow Table Pt 27
72	FLOW_TABLE_PT_28	Flow Table Pt 28
73	FLOW_TABLE_PT_29	Flow Table Pt 29
74	FLOW_TABLE_PT_30	Flow Table Pt 30
75	ENTER_PASSWORD	Enter Password
76	PRESENT_STATUS	Present Status
77	STATUS_INDICATORS_1	Status Indicators
78	STATUS_INDICATORS_2	Status Indicators
79	STATUS_INDICATORS_3	Status Indicators
80	STATUS_INDICATORS_4	Status Indicators
81	STATUS_INDICATORS_5	Status Indicators
82	STATUS_INDICATORS_6	Status Indicators
83	TREND_FLOW_VALUE	Flow
84	TREND_HEAD_VALUE	Head

IMPORTANT

SERVICE POLICY

Owners of Magnetrol products may request the return of a control; or, any part of a control for complete rebuilding or replacement. They will be rebuilt or replaced promptly. Magnetrol International will repair or replace the control, at no cost to the purchaser, (or owner) **other than transportation cost** if:

- a. Returned within the warranty period; and,
- b. The factory inspection finds the cause of the malfunction to be defective material or workmanship.

If the trouble is the result of conditions beyond our control; or, is **NOT** covered by the warranty, there will be charges for labour and the parts required to rebuild or replace the equipment.

In some cases, it may be expedient to ship replacement parts; or, in extreme cases a complete new control, to replace the original equipment before it is returned. If this is desired, notify the factory of both the model and serial numbers of the control to be replaced. In such cases, credit for the materials returned, will be determined on the basis of the applicability of our warranty.

No claims for misapplication, labour, direct or consequential damage will be allowed.

RETURNED MATERIAL PROCEDURE

So that we may efficiently process any materials that are returned, it is essential that a "Return Material Authorisation" (RMA) form will be obtained from the factory. It is mandatory that this form will be attached to each material returned. This form is available through Magnetrol's local representative or by contacting the factory. Please supply the following information:

1. Purchaser Name
2. Description of Material
3. Serial Number and Ref Number
4. Desired Action
5. Reason for Return
6. Process details

Any unit that was used in a process must be properly cleaned in accordance with the proper health and safety standards applicable by the owner, before it is returned to the factory.

A material Safety Data Sheet (MSDS) must be attached at the outside of the transport crate or box.

All shipments returned to the factory must be by prepaid transportation. Magnetrol **will not accept** collect shipments.

All replacements will be shipped Ex Works.

BULLETIN N°: BE 57-646.1
EFFECTIVE: SEPTEMBER 2016
SUPERSEDES: April 2016

UNDER RESERVE OF MODIFICATIONS



www.magnetrol.com

BENELUX FRANCE	Heikensstraat 6, 9240 Zele, België -Belgique Tel. +32 (0)52.45.11.11 • Fax. +32 (0)52.45.09.93 • E-Mail: info@magnetrol.be
DEUTSCHLAND	Alte Ziegelei 2-4, D-51491 Overath Tel. +49 (0)2204 / 9536-0 • Fax. +49 (0)2204 / 9536-53 • E-Mail: vertrieb@magnetrol.de
INDIA	B-506, Sagar Tech Plaza, Saki Naka Junction, Andheri (E), Mumbai - 400072 Tel. +91 22 2850 7903 • Fax. +91 22 2850 7904 • E-Mail: info@magnetrolindia.com
ITALIA	Via Arese 12, I-20159 Milano Tel. +39 02 607.22.98 • Fax. +39 02 668.66.52 • E-Mail: mit.gen@magnetrol.it
RUSSIA	Business center "Farvater", Ruzovskaya Street 8B, office 400A, 190013 St. Petersburg Tel. +7 812 320 70 87 • E-Mail: info@magnetrol.ru
U.A.E.	DAFZA Office 5EA 722 • PO Box 293671 • Dubai Tel. +971-4-6091735 • Fax +971-4-6091736 • E-Mail: info@magnetrol.ae
UNITED KINGDOM	Unit 1 Regent Business Centre, Jubilee Road Burgess Hill West Sussex RH 15 9TL Tel. +44 (0)1444 871313 • Fax +44 (0)1444 871317 • E-Mail: sales@magnetrol.co.uk