

DESCRIPTION

The Eclipse 705 Transmitter is a loop-powered, 24 V DC liquid-level transmitter based on the revolutionary Guided Wave Radar (GWR) technology. Encompassing a number of significant engineering accomplishments, this leading edge level transmitter is designed to provide measurement performance well beyond that of many traditional technologies, as well as “through-air” radars.

The innovative enclosure is a first in the industry, orienting dual compartments (wiring and electronics) in the same plane, and angled to maximize ease of wiring, configuration, set-up and data display.

This single transmitter can be used with all probe types and offers enhanced reliability, for use in SIL 2 / SIL 3 loops.

FEATURES

- * “REAL LEVEL”, measurement not affected by media variables eg. dielectrics, pressure, density, pH, viscosity, ...
- * Easy bench configuration - no need for level simulation.
- * Two-wire, intrinsically safe loop powered level transmitter.
- * 20-point custom strapping table for volumetric output.
- * 360° rotatable housing can be dismantled without depressurising the vessel via “Quick connect/disconnect” probe coupling.
- * Two-line, 8-character LCD and 3-button keypad.
- * Probe designs: up to +425 °C / 431 bar (+800 °F / 6250 psi).
- * Saturated steam applications up to 155 bar @ +345 °C (2250 psi @ +650 °F).
- * Cryogenic applications down to -196 °C (-320 °F).
- * Integral or remote electronics.
- * Suited for SIL 2 / SIL 3 loops (full FMEDA report and certificate available).

APPLICATIONS

MEDIA: Liquids or slurries; hydrocarbons to water-based media (dielectric 1,4 - 100) and solids (dielectric 1,9 - 100).

VESSELS: Most process or storage vessels.

CONDITIONS: All level measurement and control applications including process conditions exhibiting visible vapours, foam, surface agitation, bubbling or boiling, high fill/empty rates, low level and varying dielectric media or specific gravity.

Ask for your free copy of the Eclipse® 705 performance report by WIB/Evaluation International (SIREP)/EXERA.

^① Probe is intrinsically safe to ATEX II 1 G EEx ia IIC T6 and can be used in zone 0, on flammable liquids.

^② Foundation Fieldbus™ and Profibus PA™ units.

^③ Consult factory for proper model numbers and classifications.

Measures real «LEVEL, VOLUME, INTERFACE»

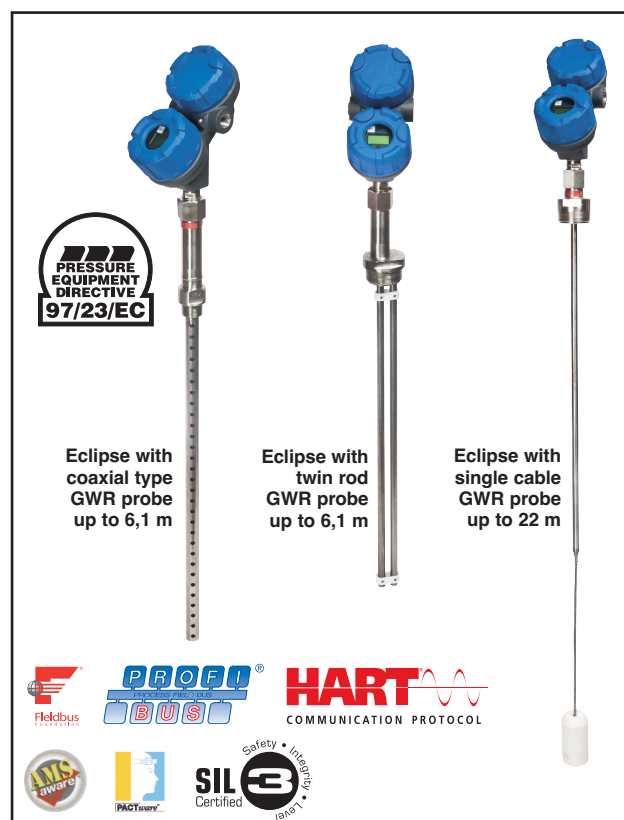

AGENCY APPROVALS

Agency	Approvals
ATEX	II 3 (1) G EEx nA [ia] IIC T6, non sparking ^① II 3 (1) G EEx nA [nL] [ia] IIC T6, FNICO – non incendive ^{②③} II 1 G Ex ia IIC T4 Ga, intrinsically safe II 1 G Ex ia IIC T4 Ga, FISCO – intrinsically safe ^② II 1/2 G Ex d[ia Ga] IIC T6 Gb II 1/2 D Ex t[ia Da] IIIC T85°C Db IP66
Lloyds	Primary level safety device for steamdrums conform to - EN 12952-11 (water tube boilers) - EN 12953-9 (shell boilers)
TÜV	WHG § 63, overflow prevention
AIB	VLAREM II – 5.17.7
LRS	Lloyds Register of Shipping (marine applications)
FM/CSA ^③	
IEC ^③	Ex d[ia Ga] IIC T6 Gb Ex t[ia Da] IIIC T85°C Db IP66 Ex ia IIC T4 Ga, intrinsically safe Ex ia IIC T4 Ga, FISCO – intrinsically safe ^② Ex ic [ia Ga] IIC T4 Gc
Russian Authorisation Standards ^③	
Other approvals are available, consult factory for more details	

TECHNOLOGY

Level

Eclipse® Guided Wave Radar is based upon the technology of TDR (Time Domain Reflectometry). TDR utilises pulses of electromagnetic energy transmitted down a wave guide (probe). When a pulse reaches a liquid surface that has a higher dielectric constant than the air (ϵ_r of 1) in which it is traveling, the pulse is reflected. The travelling time of the pulse is measured via ultra high speed timing circuitry that provides an accurate measure of the liquid level. Even after the pulse is reflected from the upper surface, some of the energy continues down the GWR probe through the upper liquid. The pulse is again reflected when it reaches the higher dielectric lower liquid, as shown in the illustration.

Interface

The Eclipse® 705, is capable of measuring both an upper liquid level and an interface liquid level. It is required that the upper liquid has a dielectric constant between 1,4 and 5, and the lower liquid has a dielectric constant greater than 15. A typical application would be oil over water, with the upper layer of oil being non-conductive ($\epsilon_r \pm 2,0$), and the lower layer of water being very conductive ($\epsilon_r \pm 80$). The thickness of the upper layer must be > 50 mm (2"). The maximum upper layer is limited to the length of the 7MT GWR probe, which is available in lengths up to 6,1 m (240").

Emulsion layers

As emulsion layers can decrease the strength of the reflected signal, the Eclipse® 705 should only be utilised in those interface applications that have clean, distinct layers. The Eclipse® 705 will tend to detect the top of the emulsion layer. Contact the factory for application assistance.

Interface

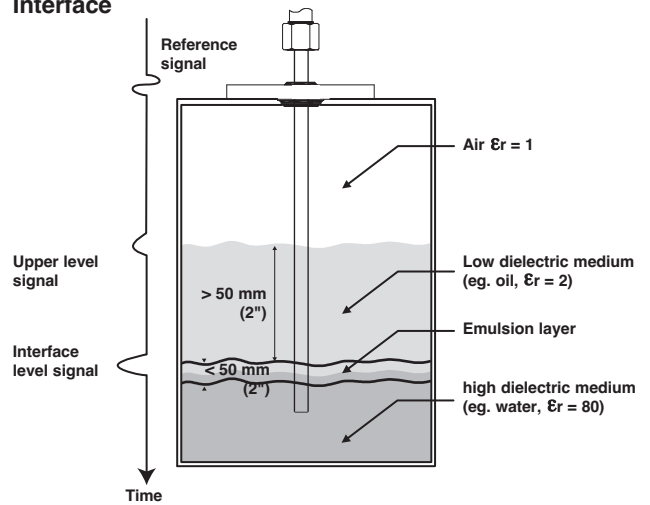

Liquid level

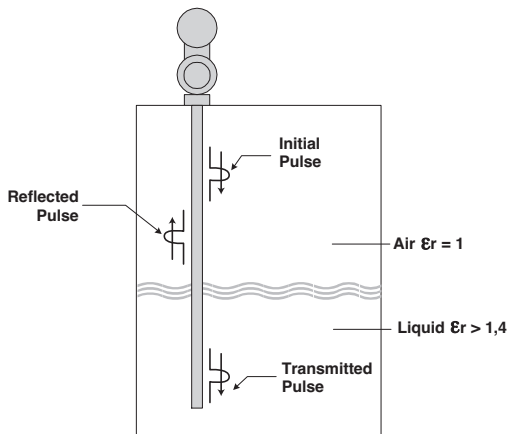

Solid level

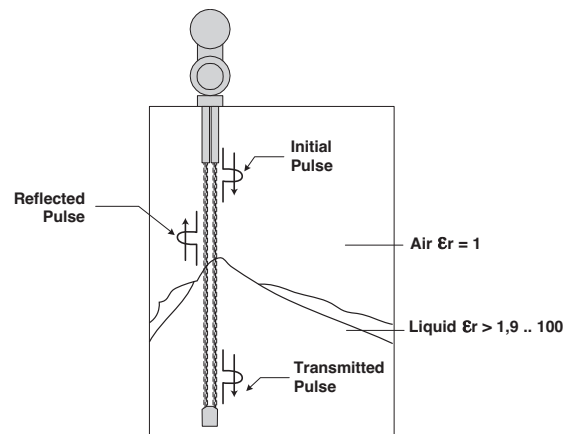

PACTware™ PC SOFTWARE PROGRAM

FDT technology provides an open communication interface between field instruments of various communication protocols and the host/ DCS system. The DTM driver is typical for one type of instrument and delivers the full functionality of the device added with graphical user interface via a laptop or PC. Magnetrol transmitters use the free shareware PACTware™ software to support DTM drivers and the FDT functionality. Via PACTware™ it becomes easy to configure, monitor and diagnose a Magnetrol transmitter from distance or even to call for factory assistance over the internet via the supply of screenshots of echo curves and trending graphs. Magnetrol DTM library HART® has passed the dtmINSPECTOR, the official FDT interoperability test and certification tool. The Magnetrol DTM's are free of charge and can be downloaded from www.magnetrol.com.



Magnetrol recommends the VIATOR® USB HART® interface from MACTek® Corporation.



REPLACEMENT OF DISPLACER TRANSMITTER

Eclipse® has proven to be the perfect replacement for existing torque tube transmitters. In hundreds of applications around the globe, customers have found Eclipse® Guided Wave Radar superior to torque tube transmitters:

- **Cost:**
A new Eclipse® costs only slightly more than rebuilding an aging torque tube.
- **Installation:**
No field calibration is necessary; it can be configured in minutes with no level movement. Pre-configuration from factory is free of charge.
- **Performance:**
Eclipse® is not affected by changes in specific gravity or dielectric.
- **Ease of replacement:**
Proprietary flanges are offered so existing chamber/ cages can be used.

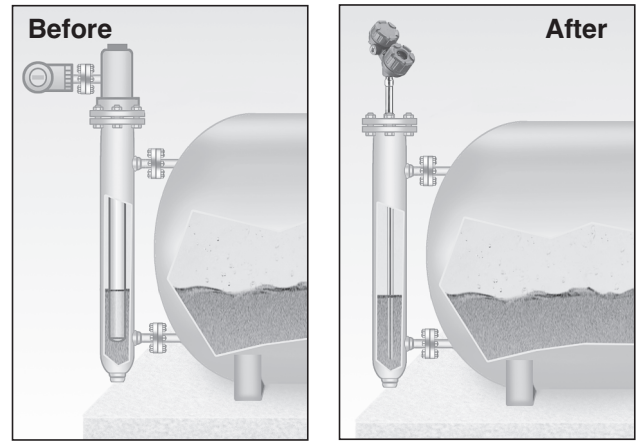

In order to match the proper Eclipse transmitter with the proper external cage, consider the following:

- **Type of application** – use the applicable GWR probe, selection guide.
- **Overflow proof:** Overflowing occurs when the level rises above the max level – radar based equipment may provide erroneous output in this zone unless an adapted design is used. GWR probes without top transition zone (e.g. 7MR, 7MD, 7MT) are always safe to use – only in cases where the application demands for a different probe type, other selections should be considered and the recommended precautions followed.
- **Min cage size:**
 - coaxial probe: min 2"/DN 50
 - twin rod probe: min 3"/DN 80
 - single rod probe: consult factory.

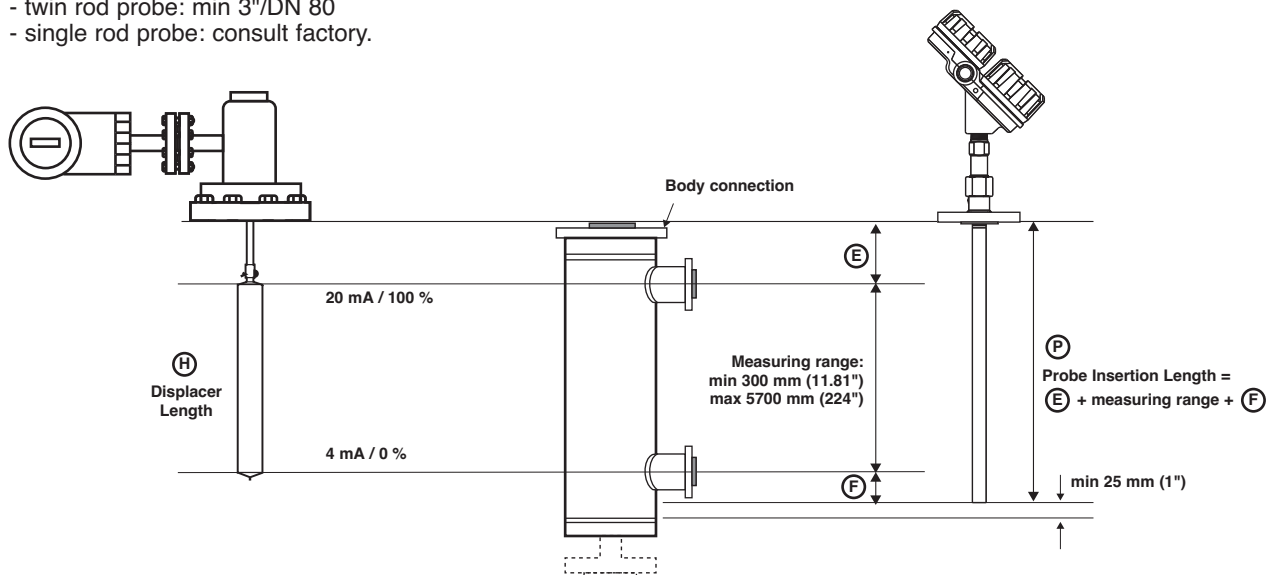

Indicative probe length for replacing displacer transmitters

Below table helps to define the GWR probe length based upon the length of the most common displacer transmitters. Consult the flange selection guide on the next page.

Manufacturer	Type	Process connection	Displacer length inches (mm)	Probe length ^① mm (inches)
Magnetrol®	EZ & PN Modulevel®	ANSI/DIN flange	≥ 14" (356)	Displacer + 178 (7)
Masoneilan®	Series 1200	Proprietary flange	≥ 14" (356)	Displacer + 203 (8)
		ANSI/DIN flange	≥ 16" (406)	Displacer + 203 (8)
Fisher® series 2300 & 2500	249B, 259B, 249C cages	Proprietary flange	≥ 14" (356)	Displacer + 254 (10)
	other cages	ANSI flange	≥ 14" (356)	consult factory
Eckhardt®	Series 134,144	ANSI/DIN flange	≥ 14" (356)	consult factory
Tokyo Keiso®	FST-3000	ANSI/DIN flange	H = 11.8" (300)	Displacer + 229 (9)
		ANSI/DIN flange	≥ H = 19.7" (500)	Displacer + 229 (9)

① Round down resulting calculation to the nearest cm.

PROPRIETARY FLANGES

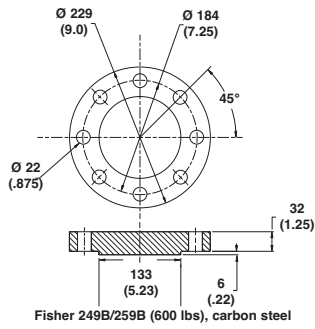

Figure 1

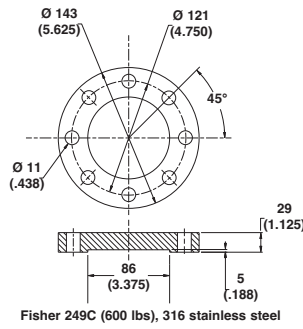

Figure 2

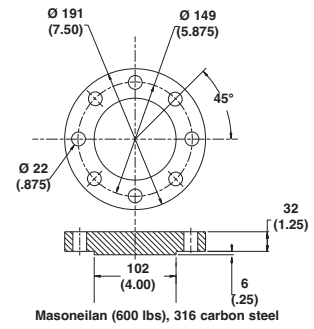

Figure 3

FLUSHING CONNECTION

The maintenance of coaxial GWR probes in applications suffering from buildup, crystallization or condensation can significantly be improved by using a flushing connection. A flushing connection is a metal extension with a vent, welded above the process connection. Via the vent it is possible to purge the inside of the coaxial GWR probe during a maintenance routine. The best approach to defeat the effects of condensation or crystallization is to install adequate insulation or heat tracing (steam or electrical). A flushing connection is no substitute for proper maintenance but will help to reduce/optimize the frequency of the maintenance routines.



CAGES

Eclipse can be built into cages as small as DN 50 / 2", depending on probe type. When a new cage is needed, it can be ordered together with the Eclipse. Magnetrol has a long tradition in offering cost effective cages. Magnetrol cages comply with PED regulations and are available with a wide variety of options.

Measuring span	30-610 cm (12-240") ^①
Materials of construction	Carbon steel or 316/316L (1.4401/1.4404) stainless steel
Process connection sizes	1", 1 1/2", 2"
Process connection ratings	150#-2500# ANSI
Configurations	Side-Side and Side-Bottom
Process pressures	Up to 431 bar (6250 psi) ^①
Process temperatures	Up to +425 °C (+800 °F) ^①

^① Limitations are defined per selected GWR probe.

For more details – consult bulletin BE 57-140.



REPLACEMENT OF TOP/BOTTOM CAGES

In addition to Magnetrol's Torque Tube Cage Flange options, the Eclipse® 705 transmitter and 7EK GWR probe/cage can also be used in replacing existing Top/Bottom and Top/Side torque tube installations. After removal of the existing torque tube cage assembly (controller, displacer and cage), Eclipse Guided Wave Radar may then be installed directly in its place. Several models are available for some of the major torque tube displacer transmitter manufacturers. Because the Model 7EK probe/cage mounting dimensions and measuring ranges match the original manufacturer's specification, no re-piping is necessary.

For more details – consult bulletin BE 57-102

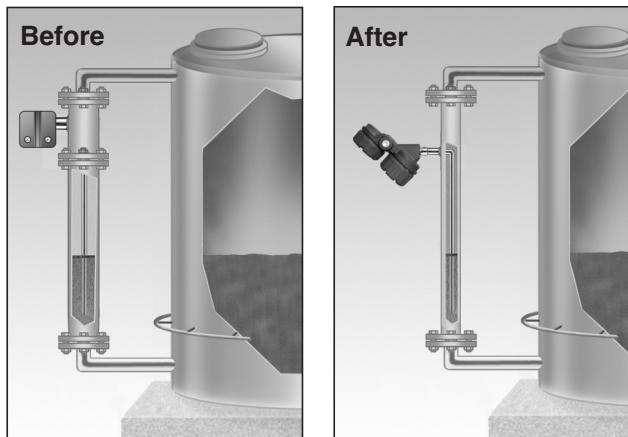

AURORA™

Aurora® is the innovative combination of the Eclipse® Guided Wave Radar and a Magnetic Level Indicator (MLI). The MLI indicator rail offers the Eclipse a highly visible level indication that may obsolete the need for local indicators. The integration of these two independent technologies provides an excellent redundancy in one integrated design. With Aurora® it is even possible to plan maintenance ahead. Maintenance becomes needed when build up in an installation has surpassed the allowable limit. Build up on the float inside the MLI cage will force it to sink deeper in the liquid while the measurement of the Eclipse will not see any build up until its both lead elements are completely clogged. In this way, the float will indicate a lower level versus the real level measured by the Eclipse. The degree of deviation between both read outs is a worthwhile tool to determine the real need for maintenance.

For more details – consult bulletin BE 57-138.



HYGIENIC ECLIPSE 705

Eclipse 705 is available with a deep drawn housing and a 0,4 μm (15 Ra) finished single rod GWR probe for use in ultra clean environments.

For more details – consult bulletin BE 57-110



SELECTION GUIDE

COAXIAL TYPE GWR PROBE



signal propagation

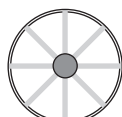

end view

TWIN ROD/CABLE TYPE GWR PROBE



signal propagation



end view

SINGLE ROD/CABLE TYPE



signal propagation

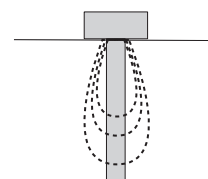

Application	Dielectric limit	Temperature limits	Pressure	Applications			GWR Probe
				Vacuum ①	Overfill safe	Foam ②	

Coaxial GWR probes - max viscosity 500 mPa.s (cP) (Consult bulletin BE 57-102 for max viscosity 2000 mPa.s (cP))

Level	ϵ_r 1,4 - 100	-40 °C up to +200 °C	max 70 bar	Yes	Yes	No	7MR/7MM
High temp / High pressure Interface	ϵ_r 1,4 - 100 ^③	-196 °C up to +425 °C	max 431 bar	Full	Yes	No	7MD/7ML
Saturated steam	ϵ_r 10 - 100	up to +300 °C	max 88 bar	Yes	No ^④	No	7MS
		up to +345 °C	max 155 bar	Yes	No ^④	No	7MQ
Interface	ϵ_r 1,4 - 100	-40 °C up to +200 °C	max 70 bar	Yes	Yes	No	7MT/7MN

Twin rod/cable GWR probes - max viscosity 1500 mPa.s (cP)

Liquids - rod	ϵ_r 1,9 - 100	-40 °C up to +150 °C	max 70 bar	Yes	No	Yes	7MB
Liquids - cable	ϵ_r 1,9 - 100	-40 °C up to +150 °C	max 70 bar	Yes	No	No	7M7
Solids - cable	ϵ_r 1,9 - 100	-40 °C up to +65 °C	max 3,45 bar	Yes	No	NA	7M5

Single rod/cable GWR probes - max viscosity 10.000 mPa.s (cP)

Liquids - rod	ϵ_r 1,9 - 100 ^⑤	-40 °C up to +150 °C	max 70 bar	Yes	No	Yes	7MF
Liquids - cable	ϵ_r 1,9 - 100 ^⑤	-40 °C up to +150 °C	max 70 bar	Yes	No	Yes	7M1
Solids - cable	ϵ_r 4 - 100	-40 °C up to +65 °C	max 3,45 bar	Yes	No	NA	7M2
High temp / high pressure	ϵ_r 1,9 - 100 ^⑤	-40 °C up to +315 °C	max 245 bar	Yes	No	Yes	7MJ

① Each Eclipse probe can be used for vacuum service (negative pressure) but only the Borosilicate GWR probes (7MD/7ML) are suited for full vacuum conditions (Helium leak < 10⁻⁸ cc/s @ 1 bar abs.)

② Eclipse is ideally suited to be used on foaming applications but in specific conditions where dense foam can enter/hydrate in the stilling well, coaxial GWR probes are not recommended.

③ Depending spacer material. See model selection 7MD/7ML GWR probe.

④ Consult factory for overfill applications.

⑤ For media with ϵ_r 1,9 up to 10, GWR probe must be mounted in between 75 mm and 150 mm (3"-6") away from the metal tank wall or in a metal cage / stillwell.

DIMENSIONS in mm (inches)

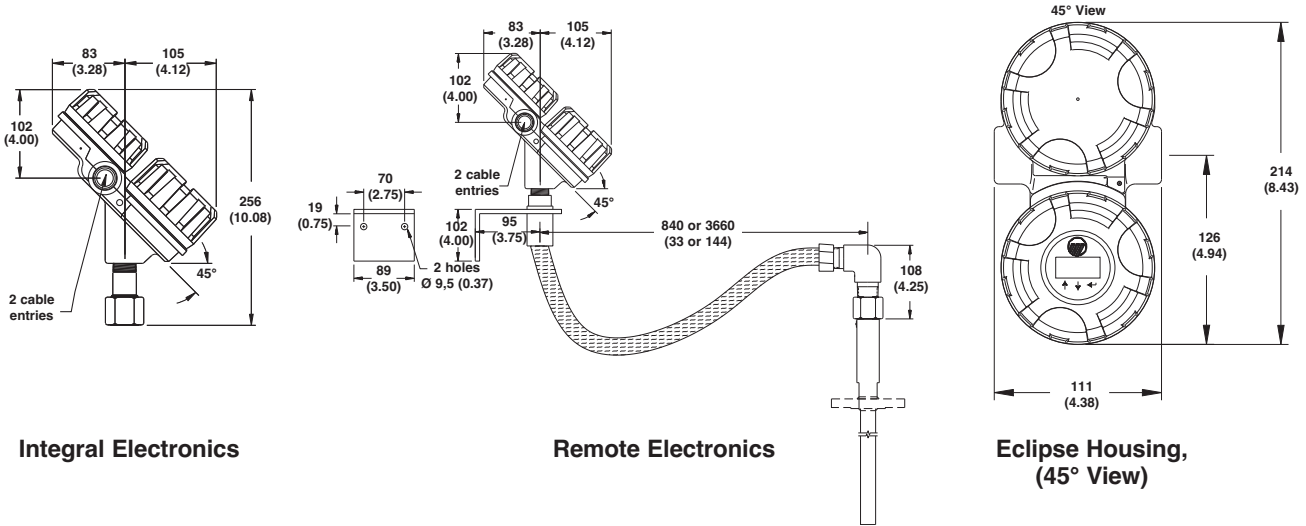

EXPEDITE SHIP PLAN (ESP)

Several models are available for quick shipment, within max. 4 weeks after factory receipt of purchase order, through the Expedite Ship Plan (ESP).

Models covered by ESP service are conveniently colour coded in the selection data charts.

To take advantage of ESP, simply match the colour coded model number codes (standard dimensions apply).

ESP service may not apply to orders of five units or more. Contact your local representative for lead times on larger volume orders, as well as other products and options.

SELECTION DATA

A complete measuring system consists of:

1. Eclipse transmitter head/electronics
2. Eclipse 705 GWR probe
3. Free of charge: Eclipse 705 DTM (PACTware™) can be downloaded from www.magnetrol.com.
4. Option: MACTek Viator USB HART® interface: order code: **070-3004-002**
5. Option:
 - TFE spacer for single rod metal GWR probes; order code: **089-9114-001** (7MF-A), **089-9114-002** (7MF-B), **089-9114-003** (7MF-C)
 - PEEK spacer for single rod 7MJ GWR probe; order code: **089-9114-005** (7MJ-A), **089-9114-006** (7MJ-B), **089-9114-007** (7MJ-C)
 - Additional weight for 7M1 GWR probe; order code: **089-9120-001**
 - Additional weight for 7M7 GWR probe; order code: **089-9121-001**
 - Additional weight for 7M2 GWR probe; order code: **004-8778-001**
 - Additional weight for 7M5 GWR probe; order code: **004-8778-002**

ELECTRICAL WIRING

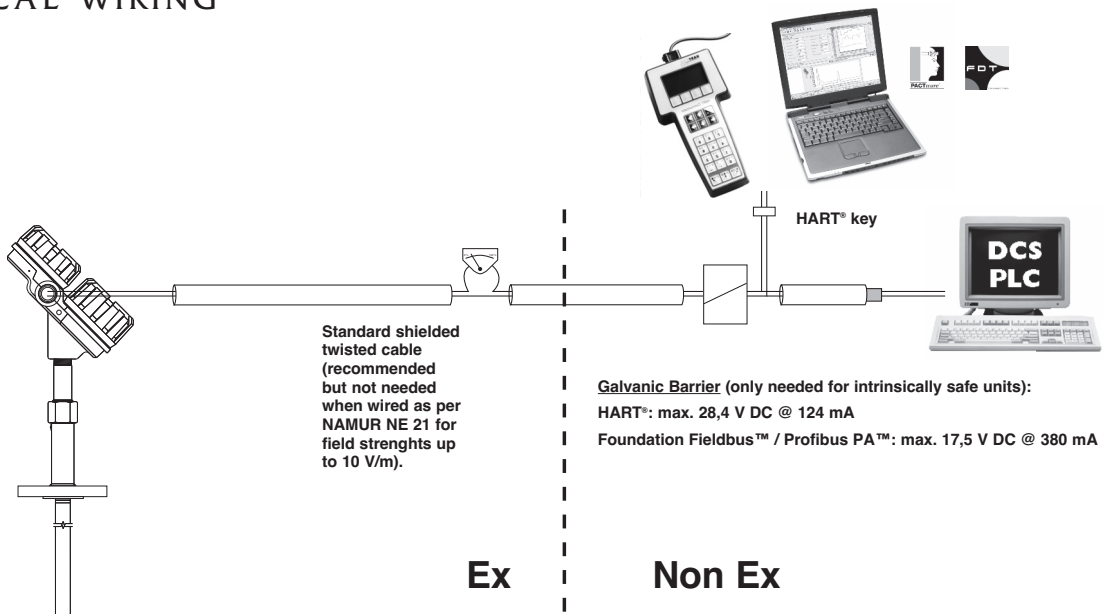

1. Order code for ECLIPSE 705 transmitter head/electronics

BASIC MODEL NUMBER

7 0 5	Eclipse 705 guided wave radar transmitter
-------	---

POWER

5	24 V DC, two wire loop powered
---	--------------------------------

OUTPUT AND ELECTRONICS

1 0	4-20 mA with HART® – standard electronics (SFF of 84.5%)
1 A	4-20 mA with HART® – SIL enhanced electronics (SFF of 91%) - certified
2 0	Foundation Fieldbus™ communication
3 0	Profibus PA™ communication

ACCESSORIES

A	Digital display and keypad
0	Blind transmitter (no display/keypad)

MOUNTING / HOUSING MATERIAL / APPROVAL^①

Integral mount electronics

Cast aluminium

1 1	Weatherproof
A 1	ATEX intrinsically safe (digit 5 = 1) / ATEX FISCO (digit 5 = 2 or 3)
C 1	ATEX flameproof enclosure
E 1	ATEX non sparking (digit 5 = 1) / ATEX FNICO (digit 5 = 2 or 3)

Cast SST[®]

1 2	Weatherproof
A 2	ATEX intrinsically safe (digit 5 = 1) / ATEX FISCO (digit 5 = 2 or 3)
C 2	ATEX flameproof enclosure
E 2	ATEX non sparking (digit 5 = 1) / ATEX FNICO (digit 5 = 2 or 3)

84 cm (33") remote mount electronics

Cast aluminium

2 1	Weatherproof
B 1	ATEX intrinsically safe (digit 5 = 1) / ATEX FISCO (digit 5 = 2 or 3)
D 1	ATEX flameproof enclosure
F 1	ATEX non sparking (digit 5 = 1) / ATEX FNICO (digit 5 = 2 or 3)

Cast SST

2 2	Weatherproof
B 2	ATEX intrinsically safe (digit 5 = 1) / ATEX FISCO (digit 5 = 2 or 3)
D 2	ATEX flameproof enclosure
F 2	ATEX non sparking (digit 5 = 1) / ATEX FNICO (digit 5 = 2 or 3)

3,66 m (144") remote mount electronics (consult factory for applications with $\epsilon_r < 10$)

Cast aluminium

2 7	Weatherproof
B 7	ATEX intrinsically safe (digit 5 = 1) / ATEX FISCO (digit 5 = 2 or 3)
D 7	ATEX flameproof enclosure
F 7	ATEX non sparking (digit 5 = 1) / ATEX FNICO (digit 5 = 2 or 3)

Cast SST

2 8	Weatherproof
B 8	ATEX intrinsically safe (digit 5 = 1) / ATEX FISCO (digit 5 = 2 or 3)
D 8	ATEX flameproof enclosure
F 8	ATEX non sparking (digit 5 = 1) / ATEX FNICO (digit 5 = 2 or 3)

^① For IEC approval, use ATEX approval and clearly request IEC nameplate.

^② To reduce the possibility of probe damage due to vibration, it is recommended to use a remote mount transmitter when ordering the heavier 316 SST version.

CABLE ENTRY

1	M20 x 1,5 (2 entries - 1 plugged)
0	3/4" NPT (2 entries - 1 plugged)

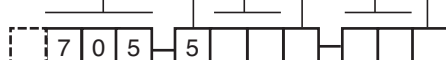

complete order code for ECLIPSE 705 transmitter head/electronics

➔ X = product with a specific customer requirement

MOUNTING – 7MR/7MM/7MT/7MN

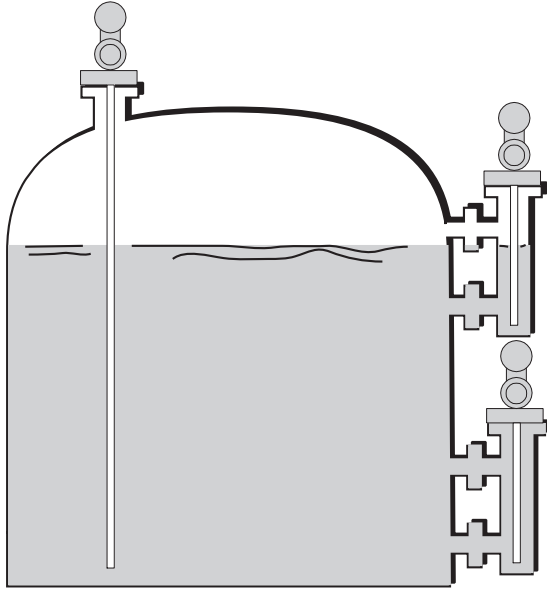

Overfill safe and Overfill proof

Eclipse 7MR, 7MM, 7MT and 7MN coaxial type GWR probes are “Overfill safe” in use and “Overfill proof” certified.

Overfill safe means that the unit is capable to measure up to the process connection. Units with “non overfill safe” probes use software to ignore level readings in the blocking distance or transitioning zone. When level rises too high in this zone, the unit may consider the end of probe reflection as the real level and may report an empty vessel instead of an overfilling vessel.

Overfill proof protection (such as WHG or VLAREM) certifies reliable operation when the transmitter is used as overfill alarm but assumes that the installation is designed in such way that the vessel/ cage cannot overflow.

DIMENSIONS in mm (inches)

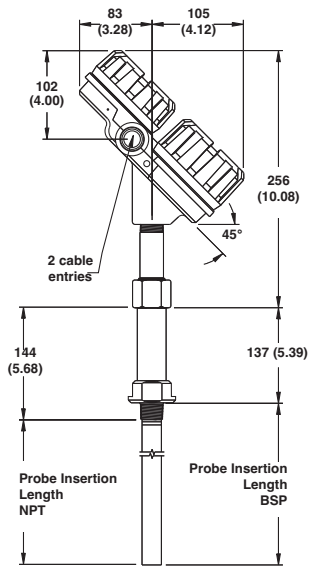

**7MR / 7MT
with threaded connection**

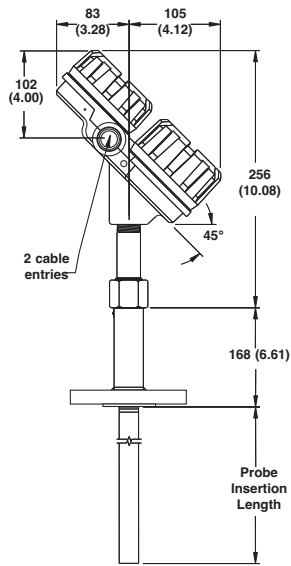

**7MR / 7MT
with flanged connection**

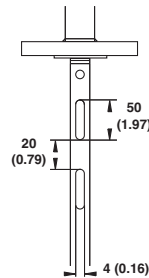

**Slots for 7MR-A
(order per “X” description)**

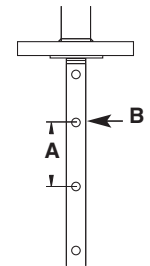

**Venting holes
for 7MR/7MM**

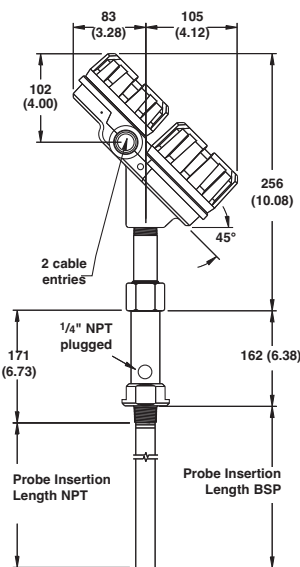

**7MM / 7MN
with threaded connection**

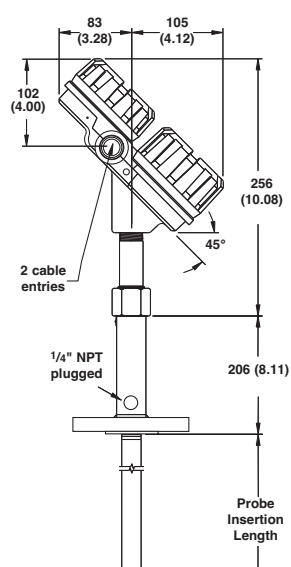

**7MM / 7MN
with flanged connection**

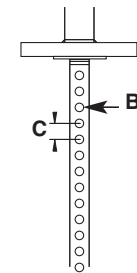

**Venting holes
for 7MT/7MN**

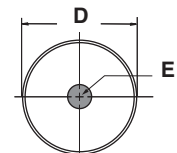

**Coaxial GWR Probe,
End View**

Dim.	mm (inch)
A	305 (12)
B	Ø 6,4 (0.25)
C	19 (0.75)
D	22,5 (0.88)
E	8 (0.315)

2. Order code for ECLIPSE 705 Coaxial GWR probe

BASIC MODEL NUMBER

GWR probe suited for external cage and/or in-tank mounting

7 M R	GWR probe for level	$\epsilon_r \geq 1,4$ - WHG approved
7 M M	GWR probe for level with flushing connection	$\epsilon_r \geq 1,4$
7 M T	GWR probe for interface	upper liq: $\epsilon_r \geq 1,4$ and ≤ 5 / lower liq: ≥ 15
7 M N	GWR probe for interface with flushing connection	upper liq: $\epsilon_r \geq 1,4$ and ≤ 5 / lower liq: ≥ 15

MATERIAL OF CONSTRUCTION

A	316/316L (1.4401/1.4404) stainless steel with Teflon® spacers
B	Hastelloy® C (2.4819) with Teflon® spacers
C	Monel® (2.4360) with Teflon® spacers

PROCESS CONNECTION - SIZE/TYPE (consult factory for other process connections)

Threaded

1 1	3/4" NPT
-----	----------

2 2	1" BSP (G 1")
-----	---------------

ANSI flanges

2 3	1"	150 lbs ANSI RF
2 4	1"	300 lbs ANSI RF
2 5	1"	600 lbs ANSI RF
3 3	1 1/2"	150 lbs ANSI RF
3 4	1 1/2"	300 lbs ANSI RF
3 5	1 1/2"	600 lbs ANSI RF
4 3	2"	150 lbs ANSI RF
4 4	2"	300 lbs ANSI RF

4 5	2"	600 lbs ANSI RF
5 3	3"	150 lbs ANSI RF
5 4	3"	300 lbs ANSI RF
5 5	3"	600 lbs ANSI RF
6 3	4"	150 lbs ANSI RF
6 4	4"	300 lbs ANSI RF
6 5	4"	600 lbs ANSI RF

EN (DIN) flanges ①

B B	DN 25	PN 16/25/40	EN 1092-1 Type A
B C	DN 25	PN 63/100	EN 1092-1 Type B2
C B	DN 40	PN 16/25/40	EN 1092-1 Type A
C C	DN 40	PN 63/100	EN 1092-1 Type B2
D A	DN 50	PN 16	EN 1092-1 Type A
D B	DN 50	PN 25/40	EN 1092-1 Type A
D D	DN 50	PN 63	EN 1092-1 Type B2
D E	DN 50	PN 100	EN 1092-1 Type B2

E A	DN 80	PN 16	EN 1092-1 Type A
E B	DN 80	PN 25/40	EN 1092-1 Type A
E D	DN 80	PN 63	EN 1092-1 Type B2
E E	DN 80	PN 100	EN 1092-1 Type B2
F A	DN 100	PN 16	EN 1092-1 Type A
F B	DN 100	PN 25/40	EN 1092-1 Type A
F D	DN 100	PN 63	EN 1092-1 Type B2
F E	DN 100	PN 100	EN 1092-1 Type B2

① Use pressure matching ANSI flange if combined with Magnetrol flanged external cage (bulletin BE 57-140).

Torque tube mating flanges ①

T T	300/600 lbs Fisher (249B/259B) in carbon steel - as per dimensions of Figure 1 on page 4
T U	300/600 lbs Fisher (249C) in stainless steel - as per dimensions of Figure 2 on page 4
U T	300/600 lbs Masoneilan flange in carbon steel - as per dimensions of Figure 3 on page 4
U U	300/600 lbs Masoneilan flange in stainless steel - as per dimensions of Figure 3 on page 4

① Always check dimensions if no ANSI/EN flanges are used.

PROCESS SEAL - MATERIAL ①

0	Viton® GFLT seal - for universal use	-40 °C (-40 °F) / +200 °C (+400 °F)
2	Kalrez® 4079 seal - for aggressive media	-40 °C (-40 °F) / +200 °C (+400 °F)
8	Aegis PF 128 seal – for steam ^② and NACE applications	-20 °C (-4 °F) / +200 °C (+400 °F)

① Consult factory for alternative seal materials. For Hydro Fluoric use, select X7MR or X7MT, "X" = for HF use". For ammonia/chlorine applications use the 7MD GWR probe.

② Max +150 °C (+300 °F) for use on steam.

INSERTION LENGTH – specify per cm (0.39") increment

0 6 0	min 60 cm (24")
6 1 0	max 610 cm (240")

Consult factory for insertion lengths < 60 cm (24")



complete order code for ECLIPSE 705 Coaxial GWR probe

➔ X = product with a specific customer requirement

MOUNTING – 7MB

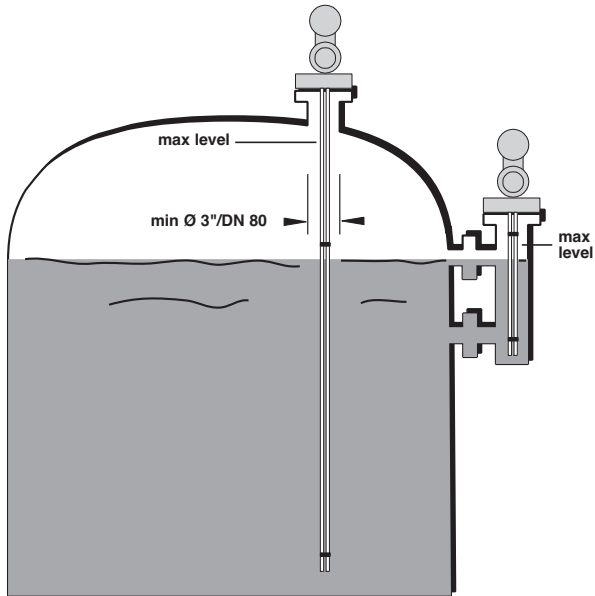

Overflow safe and Overflow protection

Eclipse twin rod GWR probes use software to ignore level readings in the transitioning zone at the top of the GWR probe. The maximum level is a minimum of 150 mm (6") below the process connection. This may include utilizing a nozzle or spool piece to raise the probe. Twin rod probes are overflow proof certified but not overflow safe in use.

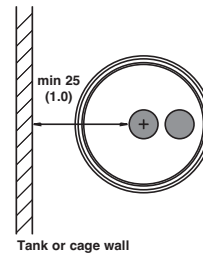

signal propagation

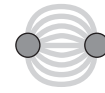

end view

Nozzles:

The nozzle should be min. Ø 3"/DN80.

DIMENSIONS in mm (inches)

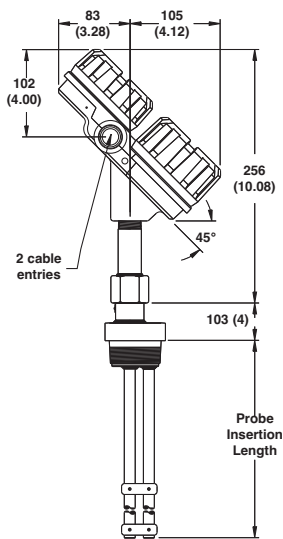

**7MB
with threaded
2" BSP (G 2") connection**

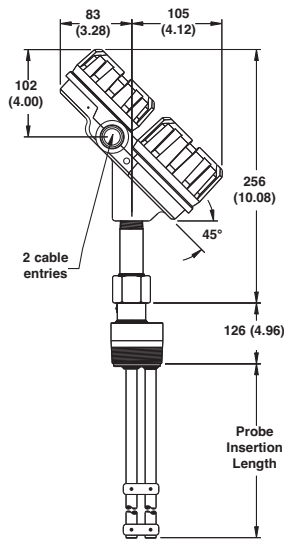

**7MB
with threaded
2" NPT connection**

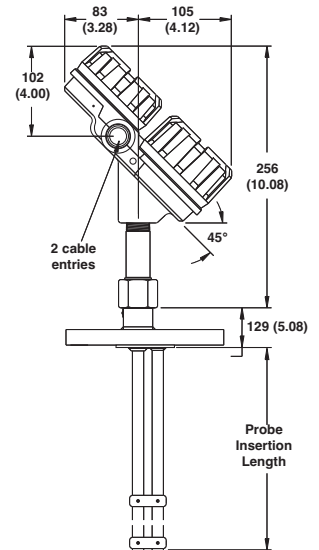

**7MB
with flanged
connection**

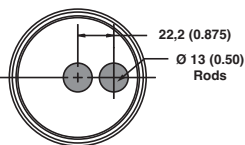

**Twin Rod GWR Probe,
End View**

2. Order code for ECLIPSE 705 Twin Rod GWR probe

BASIC MODEL NUMBER

GWR probe for in-tank mounting only

7	M	B	Twin Rod GWR probe for liquid level	(dielectric range: ≥ 1,9) - WHG approved
---	---	---	-------------------------------------	--

MATERIAL OF CONSTRUCTION

A	316/316L (1.4401/1.4404) stainless steel with Teflon® spacers
B	Hastelloy® C (2.4819) with Teflon® spacers
C	Monel® (2.4360) with Teflon® spacers

PROCESS CONNECTION - SIZE/TYPE

Threaded

4	1	2" NPT
4	2	2" BSP (G 2")

ANSI flanges (consult factory for 2" process connections)

5	3	3"	150 lbs ANSI RF
5	4	3"	300 lbs ANSI RF
5	5	3"	600 lbs ANSI RF
6	3	4"	150 lbs ANSI RF
6	4	4"	300 lbs ANSI RF
6	5	4"	600 lbs ANSI RF

EN (DIN) flanges ① (consult factory for DN 50 process connections)

E	A	DN 80	PN 16	EN 1092-1 Type A
E	B	DN 80	PN 25/40	EN 1092-1 Type A
E	D	DN 80	PN 63	EN 1092-1 Type B2
E	E	DN 80	PN 100	EN 1092-1 Type B2
F	A	DN 100	PN 16	EN 1092-1 Type A
F	B	DN 100	PN 25/40	EN 1092-1 Type A
F	D	DN 100	PN 63	EN 1092-1 Type B2
F	E	DN 100	PN 100	EN 1092-1 Type B2

① Use pressure matching ANSI flange if combined with Magnetrol flanged external cage (bulletin BE 57-140).

Torque tube mating flanges ①

T	T	300/600 lbs Fisher (249B/259B) in carbon steel - as per dimensions of Figure 1 on page 4
T	U	300/600 lbs Fisher (249C) in stainless steel - as per dimensions of Figure 2 on page 4
U	T	300/600 lbs Masoneilan flange in carbon steel - as per dimensions of Figure 3 on page 4
U	U	300/600 lbs Masoneilan flange in stainless steel - as per dimensions of Figure 3 on page 4

① Always check dimensions if no ANSI/EN flanges are used.

PROCESS SEAL - MATERIAL ①

0	Viton® GFLT seal - for universal use	-40 °C (-40 °F) / +150 °C (+300 °F)
2	Kalrez® 4079 seal - for aggressive media	-40 °C (-40 °F) / +150 °C (+300 °F)
8	Aegis PF 128 seal - for NACE applications	-20 °C (-4 °F) / +150 °C (+300 °F)

① Consult factory for alternative seal materials. For Hydro Fluoric use, select X7MR or X7MT, "X" = for HF use". For ammonia/chlorine applications use the 7MD GWR probe.

INSERTION LENGTH – specify per cm (0.39") increment
(up to 22 m (72.18') with twin cable GWR probe, see page 18 and 19)

0	6	0	min 60 cm (24")
6	1	0	max 610 cm (240")



complete order code for ECLIPSE 705 Twin Rod GWR probe

➔ X = product with a specific customer requirement

MOUNTING – 7MD/7ML/7MS/7MQ

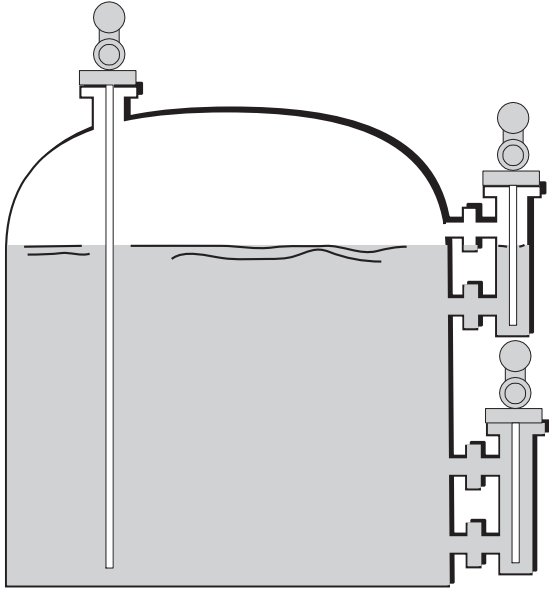

Overfill safe and Overfill protection

Eclipse 7MD and 7ML coaxial type GWR probes are “Overfill safe” in use and “Overfill proof” certified.

Overfill safe means that the unit is capable to measure up to the process connection. Units with “non overfill safe” probes use software to ignore level readings in the blocking distance or transitioning zone. When level rises too high in this zone, the unit may consider the end of probe reflection as the real level and may report an empty vessel instead of an overfilling vessel.

Overfill proof protection (such as WHG or VLAREM) certifies reliable operation when the transmitter is used as overfill alarm but assumes that the installation is designed in such way that the vessel/ cage cannot overflow.

DIMENSIONS in mm (inches)

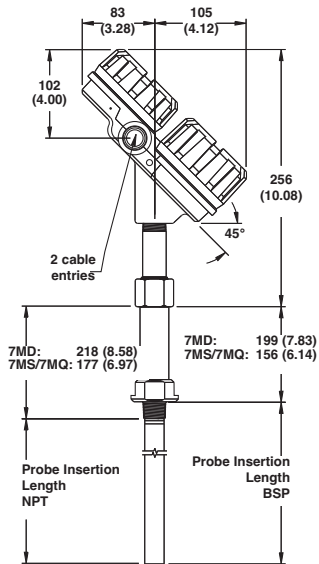

7MD/7MS/7MQ with threaded connection

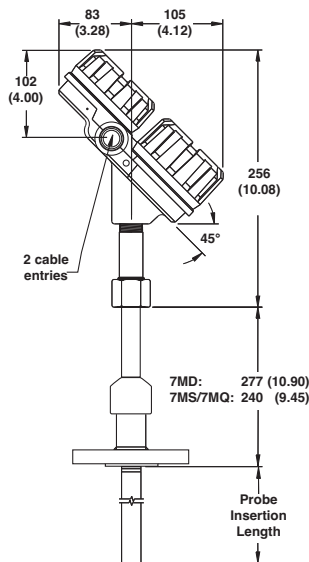

7MD/7MS/7MQ with flanged connection

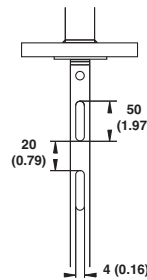

Slots for 7MD - A/V/W (order per “X” description)

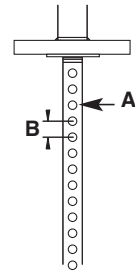

Venting holes for 7MD/7ML/7MS/7MQ

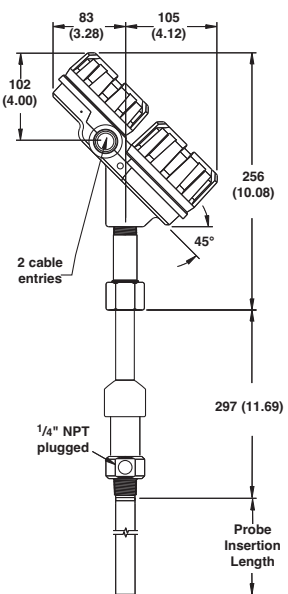

7ML with threaded connection

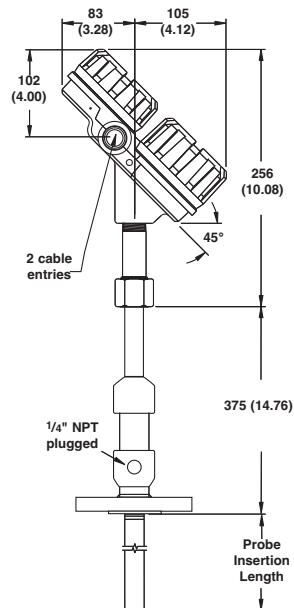

7ML with flanged connection

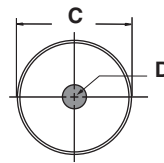

Coaxial GWR Probe, End View

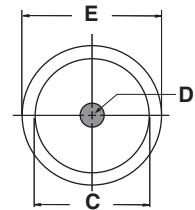

7MQ End View

Dim.	mm (inch)
A	Ø 6,4 (0.25)
B	19 (0.75)
C	22,5 (0.88)
D	8 (0.315)
E	32 (1.25)

2. Order code for ECLIPSE 705 High Temperature / High Pressure Coaxial GWR probe

7 M D	HTHP GWR probe for level/interface	WHG approved
7 M L	HTHP GWR probe for level/interface with flushing connection	

MATERIAL OF CONSTRUCTION AND MIN. DIELECTRICS / MAX. TEMPERATURE

W	316/316L (1.4401/1.4404) stainless steel with Teflon® spacers	min. dielectrics: ≥ 1,4 / max +200 °C
V	316/316L (1.4401/1.4404) SST with H. Temp PEEK® spacers	min. dielectrics: ≥ 1,7 / max +345 °C
A	316/316L (1.4401/1.4404) SST with ceramic spacers	min. dielectrics: ≥ 2,0 / max +425 °C
B	Hastelloy® C (2.4819) with ceramic spacers	min. dielectrics: ≥ 2,0 / max +425 °C
C	Monel® (2.4360) with ceramic spacers	min. dielectrics: ≥ 2,0 / max +425 °C

PROCESS CONNECTION - SIZE/TYPE (consult factory for other process connections)

Threaded

1	1	3/4" NPT
---	---	----------

2	2	1" BSP (G 1")
---	---	---------------

ANSI flanges

2	3	1"	150 lbs	ANSI RF
2	4	1"	300 lbs	ANSI RF
2	5	1"	600 lbs	ANSI RF
2	K	1"	600 lbs	ANSI RJ
2	L	1"	900 lbs	ANSI RJ
3	3	1 1/2"	150 lbs	ANSI RF
3	4	1 1/2"	300 lbs	ANSI RF
3	5	1 1/2"	600 lbs	ANSI RF
3	K	1 1/2"	600 lbs	ANSI RJ
3	M	1 1/2"	900/1500 lbs	ANSI RJ
3	N	1 1/2"	2500 lbs	ANSI RJ
4	3	2"	150 lbs	ANSI RF
4	4	2"	300 lbs	ANSI RF
4	5	2"	600 lbs	ANSI RF
4	K	2"	600 lbs	ANSI RJ
4	M	2"	900/1500 lbs	ANSI RJ

4	N	2"	2500 lbs	ANSI RJ
5	3	3"	150 lbs	ANSI RF
5	4	3"	300 lbs	ANSI RF
5	5	3"	600 lbs	ANSI RF
5	K	3"	600 lbs	ANSI RJ
5	L	3"	900 lbs	ANSI RJ
5	M	3"	1500 lbs	ANSI RJ
5	N	3"	2500 lbs	ANSI RJ
6	3	4"	150 lbs	ANSI RF
6	4	4"	300 lbs	ANSI RF
6	5	4"	600 lbs	ANSI RF
6	K	4"	600 lbs	ANSI RJ
6	L	4"	900 lbs	ANSI RJ
6	M	4"	1500 lbs	ANSI RJ
6	N	4"	2500 lbs	ANSI RJ

EN (DIN) flanges ①

B	B	DN 25	PN 16/25/40	EN 1092-1 Type A
B	C	DN 25	PN 63/100	EN 1092-1 Type B2
B	F	DN 25	PN 160	EN 1092-1 Type B2
C	B	DN 40	PN 16/25/40	EN 1092-1 Type A
C	C	DN 40	PN 63/100	EN 1092-1 Type B2
C	F	DN 40	PN 160	EN 1092-1 Type B2
C	G	DN 40	PN 250	EN 1092-1 Type B2
C	H	DN 40	PN 320	EN 1092-1 Type B2
C	J	DN 40	PN 400	EN 1092-1 Type B2
D	A	DN 50	PN 16	EN 1092-1 Type A
D	B	DN 50	PN 25/40	EN 1092-1 Type A
D	D	DN 50	PN 63	EN 1092-1 Type B2
D	E	DN 50	PN 100	EN 1092-1 Type B2
D	F	DN 50	PN 160	EN 1092-1 Type B2
D	G	DN 50	PN 250	EN 1092-1 Type B2
D	H	DN 50	PN 320	EN 1092-1 Type B2

D	J	DN 50	PN 400	EN 1092-1 Type B2
E	A	DN 80	PN 16	EN 1092-1 Type A
E	B	DN 80	PN 25/40	EN 1092-1 Type A
E	D	DN 80	PN 63	EN 1092-1 Type B2
E	E	DN 80	PN 100	EN 1092-1 Type B2
E	F	DN 80	PN 160	EN 1092-1 Type B2
E	G	DN 80	PN 250	EN 1092-1 Type B2
E	H	DN 80	PN 320	EN 1092-1 Type B2
E	J	DN 80	PN 400	EN 1092-1 Type B2
F	A	DN 100	PN 16	EN 1092-1 Type A
F	B	DN 100	PN 25/40	EN 1092-1 Type A
F	D	DN 100	PN 63	EN 1092-1 Type B2
F	E	DN 100	PN 100	EN 1092-1 Type B2
F	F	DN 100	PN 160	EN 1092-1 Type B2
F	G	DN 100	PN 250	EN 1092-1 Type B2
F	H	DN 100	PN 320	EN 1092-1 Type B2
F	J	DN 100	PN 400	EN 1092-1 Type B2

① Use pressure matching ANSI flange if combined with Magnetrol flanged external cage (bulletin BE 57-140).

Torque tube mating flanges ①

T	T	300/600 lbs Fisher (249B/259B) in carbon steel - as per dimensions of Figure 1 on page 4
T	U	300/600 lbs Fisher (249C) in stainless steel - as per dimensions of Figure 2 on page 4
U	T	300/600 lbs Masoneilan flange in carbon steel - as per dimensions of Figure 3 on page 4
U	U	300/600 lbs Masoneilan flange in stainless steel - as per dimensions of Figure 3 on page 4

① Always check dimensions if no ANSI/EN flanges are used.

PROCESS SEAL MATERIAL

N	Borosilicate / Inconel® X-750 seal – for non steam applications	-196 °C (-320 °F) / +425 °C (+800 °F)①
---	---	--

① 7MD-W: max +200 °C (+400 °F) – 7MD-V: max +345 °C (+650 °F)

INSERTION LENGTH – specify per cm (0.39") increment

0 6 0	min 60 cm (24")
6 1 0	max 610 cm (240")

Consult factory for insertion lengths < 60 cm (24")



complete order code for ECLIPSE 705 High Temperature / High Pressure Coaxial GWR probe

X = product with a specific customer requirement

2. Order code for ECLIPSE 705 Coaxial GWR probe for saturated steam

7 M S	Coaxial GWR probe for saturated steam applications, incl. steam compensation / reference target; 300 °C (575 °F) max.
7 M Q	Coaxial GWR probe for saturated steam applications, incl. steam compensation / reference target; 345 °C (650 °F) max.

MATERIAL OF CONSTRUCTION

A	316/316L (1.4401/1.4404) stainless steel
---	--

PROCESS CONNECTION - SIZE/TYPE (consult factory for other process connections)

Threaded^①

1 1	3/4" NPT
-----	----------

2 2	1" BSP (G 1")
-----	---------------

ANSI flanges

2 3	1"	150 lbs	ANSI RF ^①
2 4	1"	300 lbs	ANSI RF ^①
2 5	1"	600 lbs	ANSI RF ^①
2 K	1"	600 lbs	ANSI RJ ^②
2 L	1"	900 lbs	ANSI RJ ^②
3 3	1 1/2"	150 lbs	ANSI RF
3 4	1 1/2"	300 lbs	ANSI RF
3 5	1 1/2"	600 lbs	ANSI RF
3 K	1 1/2"	600 lbs	ANSI RJ
3 M	1 1/2"	900/1500 lbs	ANSI RJ
3 N	1 1/2"	2500 lbs	ANSI RJ
4 3	2"	150 lbs	ANSI RF
4 4	2"	300 lbs	ANSI RF
4 5	2"	600 lbs	ANSI RF
4 K	2"	600 lbs	ANSI RJ
4 M	2"	900/1500 lbs	ANSI RJ

4 N	2"	2500 lbs	ANSI RJ
5 3	3"	150 lbs	ANSI RF
5 4	3"	300 lbs	ANSI RF
5 5	3"	600 lbs	ANSI RF
5 K	3"	600 lbs	ANSI RJ
5 L	3"	900 lbs	ANSI RJ
5 M	3"	1500 lbs	ANSI RJ
5 N	3"	2500 lbs	ANSI RJ
6 3	4"	150 lbs	ANSI RF
6 4	4"	300 lbs	ANSI RF
6 5	4"	600 lbs	ANSI RF
6 K	4"	600 lbs	ANSI RJ
6 L	4"	900 lbs	ANSI RJ
6 M	4"	1500 lbs	ANSI RJ
6 N	4"	2500 lbs	ANSI RJ

EN (DIN) flanges^②

B B	DN 25	PN 16/25/40	EN 1092-1 Type A ^①
B C	DN 25	PN 63/100	EN 1092-1 Type B2 ^②
B F	DN 25	PN 160	EN 1092-1 Type B2 ^②
C B	DN 40	PN 16/25/40	EN 1092-1 Type A
C C	DN 40	PN 63/100	EN 1092-1 Type B2
C F	DN 40	PN 160	EN 1092-1 Type B2
C G	DN 40	PN 250	EN 1092-1 Type B2
C H	DN 40	PN 320	EN 1092-1 Type B2
C J	DN 40	PN 400	EN 1092-1 Type B2
D A	DN 50	PN 16	EN 1092-1 Type A
D B	DN 50	PN 25/40	EN 1092-1 Type A
D D	DN 50	PN 63	EN 1092-1 Type B2
D E	DN 50	PN 100	EN 1092-1 Type B2
D F	DN 50	PN 160	EN 1092-1 Type B2
D G	DN 50	PN 250	EN 1092-1 Type B2
D H	DN 50	PN 320	EN 1092-1 Type B2

D J	DN 50	PN 400	EN 1092-1 Type B2
E A	DN 80	PN 16	EN 1092-1 Type A
E B	DN 80	PN 25/40	EN 1092-1 Type A
E D	DN 80	PN 63	EN 1092-1 Type B2
E E	DN 80	PN 100	EN 1092-1 Type B2
E F	DN 80	PN 160	EN 1092-1 Type B2
E G	DN 80	PN 250	EN 1092-1 Type B2
E H	DN 80	PN 320	EN 1092-1 Type B2
E J	DN 80	PN 400	EN 1092-1 Type B2
F A	DN 100	PN 16	EN 1092-1 Type A
F B	DN 100	PN 25/40	EN 1092-1 Type A
F D	DN 100	PN 63	EN 1092-1 Type B2
F E	DN 100	PN 100	EN 1092-1 Type B2
F F	DN 100	PN 160	EN 1092-1 Type B2
F G	DN 100	PN 250	EN 1092-1 Type B2
F H	DN 100	PN 320	EN 1092-1 Type B2
F J	DN 100	PN 400	EN 1092-1 Type B2

Torque tube mating flanges^③

T T	300/600 lbs Fisher (249B/259B) in carbon steel - as per dimensions of Figure 1 on page 4
T U	300/600 lbs Fisher (249C) in stainless steel - as per dimensions of Figure 2 on page 4
U T	300/600 lbs Masoneilan flange in carbon steel - as per dimensions of Figure 3 on page 4
U U	300/600 lbs Masoneilan flange in stainless steel - as per dimensions of Figure 3 on page 4

- ① Not available with 7MQ probe.
- ② Use pressure matching ANSI flange if combined with Magnetrol flanged external cage (bulletin BE 57-140).
- ③ Always check dimensions if no ANSI/EN flanges are used.

PROCESS SEAL MATERIAL

8	Steam seal
---	------------

INSERTION LENGTH – specify per cm (0.39") increment

0 6 0	min 60 cm (24") with single bottom spacer
4 5 0	max 450 cm (177") with spacers every 60 cm (24")

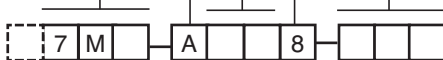

complete order code for ECLIPSE 705 Coaxial GWR probe for saturated steam

→ X = product with a specific customer requirement

MOUNTING CONSIDERATIONS

1. Turbulence

For 7MF/7M1/7M2/7MJ (single rod/cable)

The bottom of the probe should be stabilized if turbulence will cause a deflection of more than 75 mm at 3 m (3' at 10') of length. The probe should not make contact with a metal tank. A TFE bottom spacer for 7MF GWR probes, a PEEK spacer for 7MJ or an additional weight for flexible cable GWR probes is optional. Refer to page 6 for proper part numbers.

2. Nozzles: do not restrict the performance by ensuring the following:

For 7MF/7M1/7M2/7MJ (single rod/cable):

- Nozzle must be 50 mm (2") or larger diameter.
- Nozzle inside diameter (**A**) should be \geq to nozzle height (**B**). If this is not the case, it is recommended to adjust BLOCKING DISTANCE and/or SENSITIVITY settings.

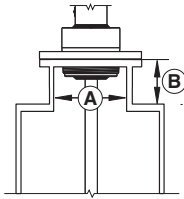

Correct installation

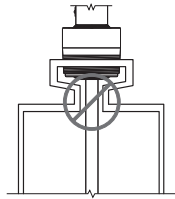

Pipe reducers should not be used

For 7M5/7M7 (twin cable):

- Nozzle should be DN80 (3") diameter or larger.
- For nozzles < DN80 (3") diameter, the bottom of the inactive section of the probe should be flush with the bottom of the nozzle or extend into the vessel.

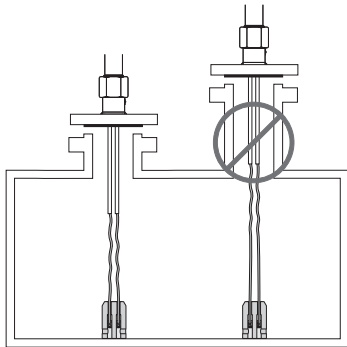

3. Metallic (conductive) obstructions in tank.

For 7MF/7M1/7M2 (single cable)

A metal stillwell/cage of max. 6"/DN150 size or a metal tank wall within 150 mm of the probe mounting will allow the unit to operate accurately in media with dielectrics down to ϵ_r 1.9.

Objects in the proximity can cause erroneous readings.

Distance to probe	Acceptable objects
< 150 mm (6")	Continuous, smooth, parallel, conductive surface (e.g. metal tank wall); probe should not touch tank wall
> 150 mm (6")	< 1"/DN25 diameter pipe and beams, ladder rungs
> 300 mm (12")	< 3"/DN80 diameter pipe and beams, concrete walls
> 450 mm (18")	All remaining objects

For 7M5/7M7 (twin cable)

Mount the probe more than 25 mm (1") from any metallic object/vesselwall.

4. Non-metallic vessels

For 7MF/7M1/7M2/7MJ (single rod/cable)

Flange (metal) mounting is recommended for optimum performance.

High level shutdown / Overfill protection

Special consideration is necessary in any high level shutdown / overfill protection application where single rod GWR probes are used. To ensure proper measurement, the guided wave radar probe should be installed so the maximum overfill level is at a minimum of 120 mm (4.8") up to 910 mm (36") – blocking distance depending application below the process connection. Consult factory for further information.

Single rod probes

Single element GWR probes act quite differently from coaxial and twin element designs. The pulses of energy develop between the center rod and the mounting nut or flange; the pulse propagates down the rod as it references its ground at the top of the tank. The efficiency of the pulse "launch" is directly related to how much metallic surface exists around it at the top of the vessel.

This figure shows the single element design and how the pulse expands into a teardrop shape as it propagates away from the top of the tank (ground reference). This Single element configuration is the least efficient of the three with minimum dielectric detection approximately $\epsilon_r > 10$. This dielectric performance improves considerably ($\epsilon_r > 1.9$) when the probe is installed between 2–6" (50–150 mm) of a metal tank wall or in a cage/bridle. Because the design is "open", it exhibits two strong tendencies. First, it is the most forgiving of coating and buildup. (The PFA-insulated probe is the best choice for severe coating). Secondly, it is most affected by proximity issues. It is important to note that a parallel metal wall INCREASES its performance while a singular, metal object protruding near the probe may be improperly detected as a liquid level.

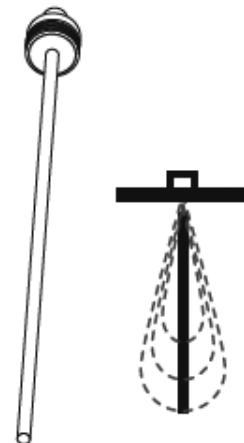

Single Rod Probe

MOUNTING – 7MF/7MJ

Consult mounting considerations on page 15

DIMENSIONS in mm (inches)

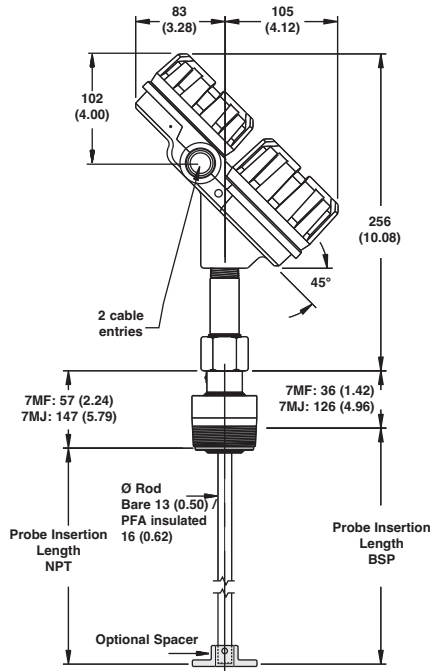

**7MF/7MJ
with threaded connection**

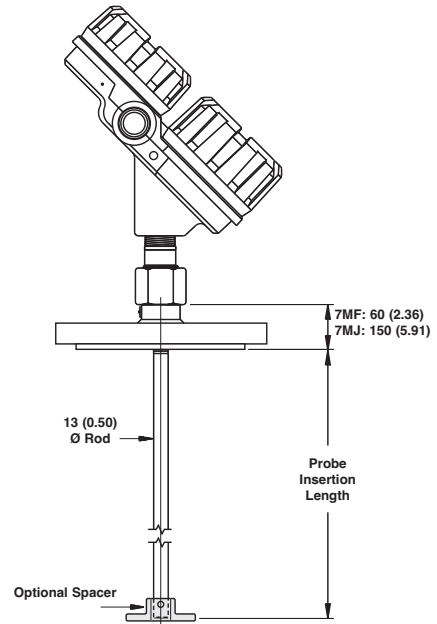

**7MF/7MJ
with flanged connection**

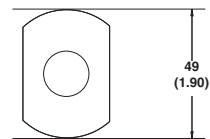

Spacer (end view)

2. Order code for ECLIPSE 705 GWR probe for liquids (for in-tank mounting only)

- 316/316L (1.4401/1.4404) material for standard applications
- Hastelloy® C (2.4819) or Monel® (2.4360) for extreme aggressive media
- PFA insulated for applications with excessive coating / build up.

BASIC MODEL NUMBER

7 M F	Standard single rod GWR probe	(dielectric range: ≥ 1,9/10) ^①
7 M J	High temperature / high pressure single rod GWR probe	(dielectric range: ≥ 1,9/10) ^①

^① For dielectric range ≥ 1,9 and < 10, probe must be mounted within 50 - 150 mm (2" - 6") distance from the tank wall or in a cage or bridle. See mounting considerations on page 15

MATERIAL OF CONSTRUCTION

A	316/316L (1.4401/1.4404) stainless steel
B	Hastelloy® C (2.4819)
C	Monel® (2.4360)
4	PFA insulated 316/316L (1.4401/1.4404) SST – 7MF only

PROCESS CONNECTION - SIZE/TYPE

Threaded

4 1	2" NPT
4 2	2" BSP (G 2")

ANSI flanges ^①

4 3	2" 150 lbs	ANSI RF
4 4	2" 300 lbs	ANSI RF
4 5	2" 600 lbs	ANSI RF
4 K	2" 600 lbs	ANSI RJ
4 M	2" 900/1500 lbs	ANSI RJ
5 3	3" 150 lbs	ANSI RF
5 4	3" 300 lbs	ANSI RF
5 5	3" 600 lbs	ANSI RF
5 K	3" 600 lbs	ANSI RJ
5 L	3" 900 lbs	ANSI RJ
5 M	3" 1500 lbs	ANSI RJ
6 3	4" 150 lbs	ANSI RF
6 4	4" 300 lbs	ANSI RF
6 5	4" 600 lbs	ANSI RF
6 K	4" 600 lbs	ANSI RJ
6 L	4" 900 lbs	ANSI RJ
6 M	4" 1500 lbs	ANSI RJ

EN (DIN) flanges ^{①②}

D A	DN 50 PN 16	EN 1092-1 Type A
D B	DN 50 PN 25/40	EN 1092-1 Type A
D D	DN 50 PN 63	EN 1092-1 Type B2
D E	DN 50 PN 100	EN 1092-1 Type B2
D F	DN 50 PN 160	EN 1092-1 Type B2
D G	DN 50 PN 250	EN 1092-1 Type B2
E A	DN 80 PN 16	EN 1092-1 Type A
E B	DN 80 PN 25/40	EN 1092-1 Type A
E D	DN 80 PN 63	EN 1092-1 Type B2
E E	DN 80 PN 100	EN 1092-1 Type B2
E F	DN 80 PN 160	EN 1092-1 Type B2
E G	DN 80 PN 250	EN 1092-1 Type B2
F A	DN 100 PN 16	EN 1092-1 Type A
F B	DN 100 PN 25/40	EN 1092-1 Type A
F D	DN 100 PN 63	EN 1092-1 Type B2
F E	DN 100 PN 100	EN 1092-1 Type B2
F F	DN 100 PN 160	EN 1092-1 Type B2
F G	DN 100 PN 250	EN 1092-1 Type B2

^① 7MF up to 600 lbs ANSI RF / PN 100 flanges
^② Use pressure matching ANSI flange if combined with Magnetrol flanged external cage (bulletin BE 57-140).

PROCESS SEAL - MATERIAL

For 7MF

0	Viton® GFLT seal - for universal use	-40 °C (-40 °F) / +150 °C (+300 °F)
2	Kalrez® 4079 seal - for aggressive media	-40 °C (-40 °F) / +150 °C (+300 °F)
8	Aegis PF 128 seal - for NACE applications	-20 °C (-4 °F) / +150 °C (+300 °F)

For 7MJ

8	PEEK/Aegis PF 128 seal	-15 °C (-0 °F) / +315 °C (+600 °F)
---	------------------------	------------------------------------

Consult factory for alternative seal materials. For Ammonia/Chlorine applications, use the 7MD GWR probe.

INSERTION LENGTH – Specify per cm (0.39") increment

0 6 0	minimum 60 cm (24")
6 1 0	maximum 610 cm (240")



complete order code for ECLIPSE 705 - bare or PFA insulated GWR probe

→ X = product with a specific customer requirement

MOUNTING – 7MF-F

Consult mounting considerations on page 15

DIMENSIONS in mm (inches)

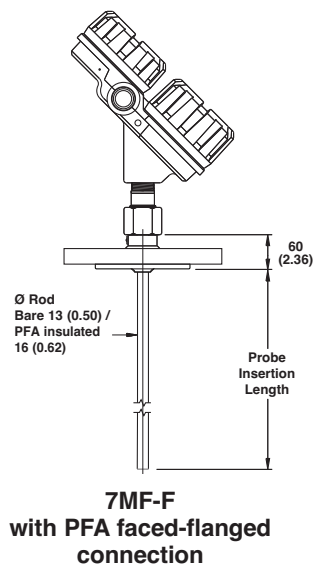

2. Order code for ECLIPSE 705 - PFA insulated / PFA faced flange GWR probe - for aggressive liquids

BASIC MODEL NUMBER

7	M	F	-	F	Single rod PFA insulated 316/316L (1.4401/1.4404) GWR probe	(dielectric range: $\geq 1,9/10$) ^①
---	---	---	---	---	---	---

^① For dielectric range $\geq 1,9$ and < 10 , probe must be mounted within 50 - 150 mm (2" - 6") distance from the tank wall or in a cage or bridle. See mounting considerations on page 15

PROCESS CONNECTION - SIZE/TYPE

ANSI flanges

4 3 N	2" 150 lbs ANSI RF
4 4 N	2" 300 lbs ANSI RF
4 5 N	2" 600 lbs ANSI RF
5 3 N	3" 150 lbs ANSI RF
5 4 N	3" 300 lbs ANSI RF
5 5 N	3" 600 lbs ANSI RF
6 3 N	4" 150 lbs ANSI RF
6 4 N	4" 300 lbs ANSI RF
6 5 N	4" 600 lbs ANSI RF

EN (DIN) flanges ^①

D A N	DN 50 PN 16	EN 1092-1 Type A
D B N	DN 50 PN 25/40	EN 1092-1 Type A
D D N	DN 50 PN 63	EN 1092-1 Type B2
D E N	DN 50 PN 100	EN 1092-1 Type B2
E A N	DN 80 PN 16	EN 1092-1 Type A
E B N	DN 80 PN 25/40	EN 1092-1 Type A
E D N	DN 80 PN 63	EN 1092-1 Type B2
E E N	DN 80 PN 100	EN 1092-1 Type B2
F A N	DN 100 PN 16	EN 1092-1 Type A
F B N	DN 100 PN 25/40	EN 1092-1 Type A
F D N	DN 100 PN 63	EN 1092-1 Type B2
F E N	DN 100 PN 100	EN 1092-1 Type B2

^① Use pressure matching ANSI flange if combined with Magnetrol flanged external cage (bulletin BE 57-140).

INSERTION LENGTH – Specify per cm (0.39") increment

0 6 0	minimum 60 cm (24")
6 1 0	maximum 610 cm (240")

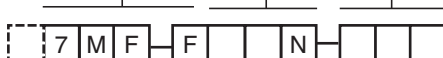

ECLIPSE 705 - PFA insulated / PFA faced flange GWR probe

→ X = product with a specific customer requirement

MOUNTING – 7M1/7M2/7M5/7M7

Consult mounting considerations on page 15

DIMENSIONS in mm (inches)

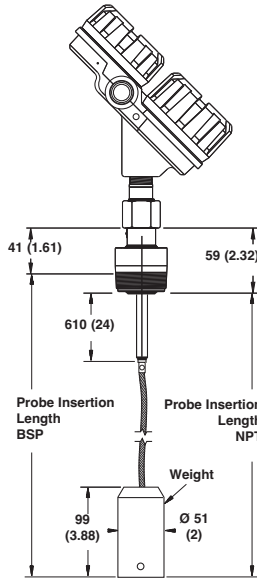

7M1
with threaded connection

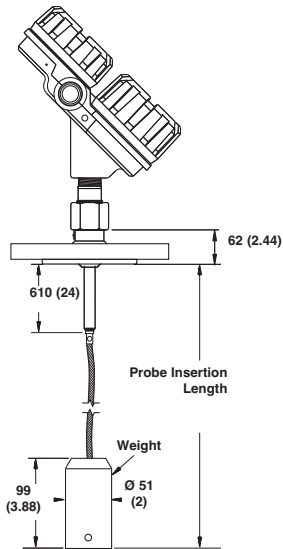

7M1
with flanged connection

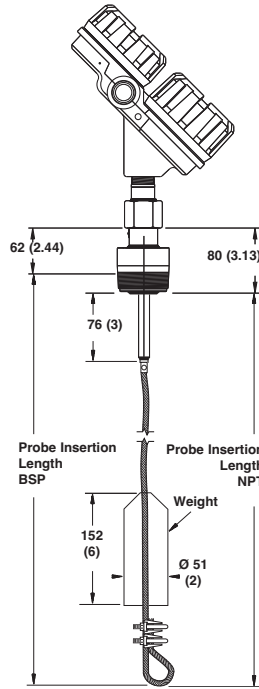

7M2
with threaded connection

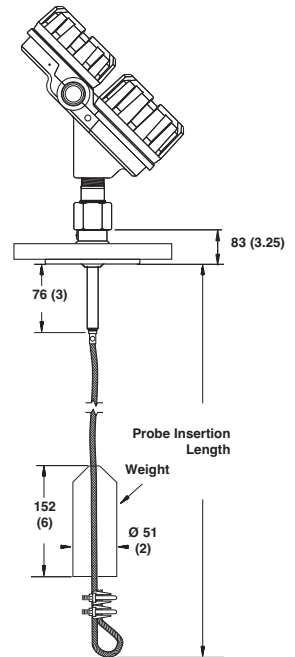

7M2
with flanged connection

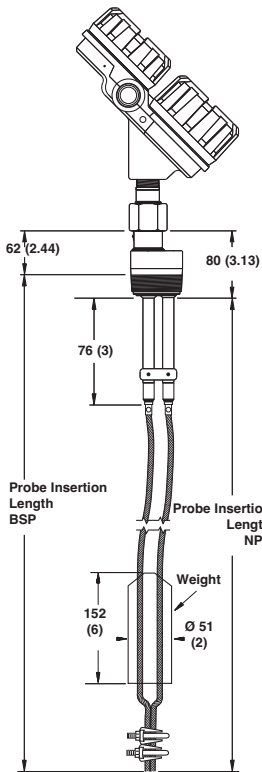

7M5
with threaded connection

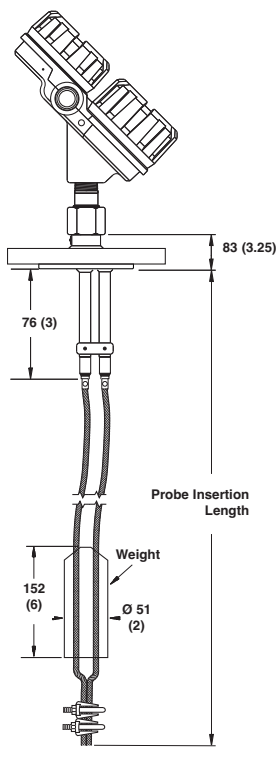

7M5
with flanged connection

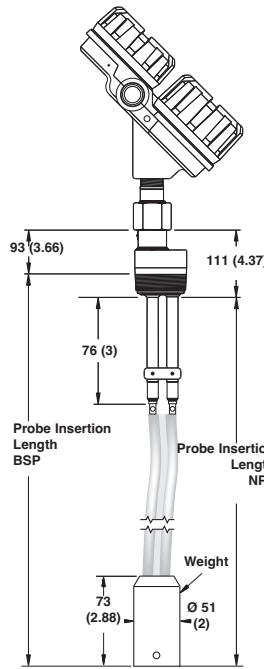

7M7
with threaded connection

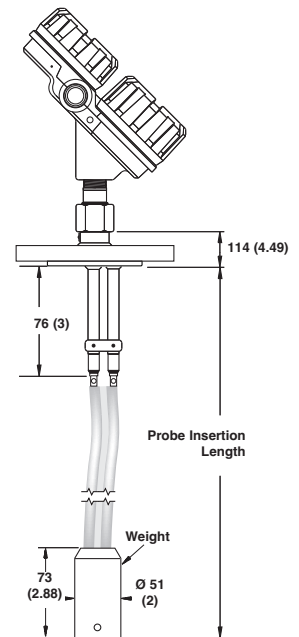

7M7
with flanged connection

ADDITIONAL WEIGHT (refer to page 6 for proper part numbers)

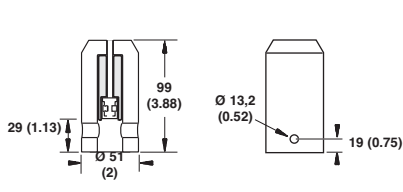

TFE Weight
450 g (1 lb.)
7M1

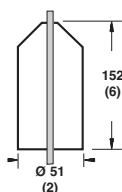

SST Weight
2,25 kg (5 lbs)
7M2

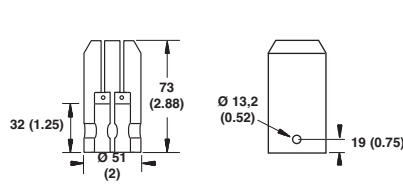

TFE Weight
284 g (10 oz.)
7M7

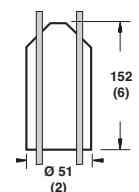

SST Weight
2,25 kg (5 lbs)
7M5

2. Order code for ECLIPSE 705 - flexible cable GWR probe for liquids or solids

BASIC MODEL NUMBER

7 M 1 - A	Single cable GWR probe in 316 stainless steel (1.4401) – for liquids $\epsilon_r \geq 1,9/10^{\text{①}}$ / max +150 °C
7 M 7 - A	Twin cable GWR probe in FEP coated 316 SST (1.4401) – for liquids $\epsilon_r \geq 1,9$ / max +150 °C
7 M 2 - A	Single cable GWR probe in 316 stainless steel (1.4401) – for solids $\epsilon_r \geq 4$ / max +65 °C
7 M 5 - A	Twin cable GWR probe in FEP coated 316 SST (1.4401) – for solids $\epsilon_r \geq 1,9$ / max +65 °C

① For dielectric range $\geq 1,9$ and < 10 , probe must be mounted within 50 - 150 mm (2" - 6") distance from the tank wall or in a cage or bridle. See mounting considerations on page 15

PROCESS CONNECTION - SIZE/TYPE

Threaded

4 1	2" NPT
4 2	2" BSP (G 2")

ANSI flanges

4 3	2" 150 lbs ANSI RF	– 7M1/7M2 only
4 4	2" 300 lbs ANSI RF	– 7M1/7M2 only
4 5	2" 600 lbs ANSI RF	– 7M1/7M2 only
5 3	3" 150 lbs ANSI RF	
5 4	3" 300 lbs ANSI RF	
5 5	3" 600 lbs ANSI RF	
6 3	4" 150 lbs ANSI RF	
6 4	4" 300 lbs ANSI RF	
6 5	4" 600 lbs ANSI RF	

EN (DIN) flanges

D A	DN 50 PN 16	EN 1092-1 Type A	– 7M1/7M2 only
D B	DN 50 PN 25/40	EN 1092-1 Type A	– 7M1/7M2 only
D D	DN 50 PN 63	EN 1092-1 Type B2	– 7M1/7M2 only
D E	DN 50 PN 100	EN 1092-1 Type B2	– 7M1/7M2 only
E A	DN 80 PN 16	EN 1092-1 Type A	
E B	DN 80 PN 25/40	EN 1092-1 Type A	
E D	DN 80 PN 63	EN 1092-1 Type B2	
E E	DN 80 PN 100	EN 1092-1 Type B2	
F A	DN 100 PN 16	EN 1092-1 Type A	
F B	DN 100 PN 25/40	EN 1092-1 Type A	
F D	DN 100 PN 63	EN 1092-1 Type B2	
F E	DN 100 PN 100	EN 1092-1 Type B2	

PROCESS SEAL - MATERIAL

For 7M1/7M7

0	Viton® GFLT seal - for universal use	-40 °C (-40 °F) / +150 °C (+300 °F)
2	Kalrez® 4079 seal - for aggressive media	-40 °C (-40 °F) / +150 °C (+300 °F)
8	Aegis PF 128 seal – for NACE applications	-20 °C (-4 °F) / +150 °C (+300 °F)

Consult factory for alternative seal materials. For ammonia/chloride applications, use the 7MD GWR probe.

For 7M2/7M5

0	Viton® GFLT seal - for universal use	-40 °C (-40 °F) / +65 °C (+150 °F)
---	--------------------------------------	------------------------------------

INSERTION LENGTH: – Specify per m (3,28') increment
Probes can be cut to exact length in the field

0 0 2	minimum 2 m (6.56')
0 2 2	maximum 22 m (72.18')



complete order code for ECLIPSE 705 - flexible cable GWR probe

➔ X = product with a specific customer requirement

TRANSMITTER SPECIFICATIONS

FUNCTIONAL/PHYSICAL

Description		Specification
Power (at terminals)		HART®: - Weatherproof / ATEX flameproof enclosure / ATEX non sparking: 11 to 36 V DC - ATEX Intrinsically Safe: 11 to 28,4 V DC Foundation Fieldbus™ / Profibus PA™: - Weatherproof / ATEX flameproof enclosure / ATEX FNICO: 9 to 32 V DC - ATEX FISCO: 9 to 17,5 V DC
Output		4-20 mA with HART®, 3,8 mA to 20,5 mA useable (meets NAMUR NE 43) – HART 6, Foundation Fieldbus™ H1 or Profibus PA™ H1
Span		15 cm to 22 m (6" to 72.18") depending on selected probe
Resolution		Analog: 0,01 mA Display: 0,1 (cm or inch)
Loop Resistance		630 Ω @ 20,5 mA - 24 V DC
Damping		Adjustable 0-10 s
Diagnostic Alarm		Adjustable 3,6 mA, 22 mA, HOLD last output
User Interface		HART® communicator, AMS® or PACTware™, Foundation Fieldbus™, Profibus PA™ and/or 3-button keypad
Display		2-line x 8-character LCD
Menu Language		English/Spanish/French/German (Foundation Fieldbus™, Profibus PA™: English)
Housing Material		IP 66/Aluminium A356T6 (< 0.20 % copper) or stainless steel
Approvals		ATEX II 3 (1) G EEx nA [ja] IIC T6, non sparking (probe can be used in flammable liquids) ATEX II 3 (1) G EEx nA [nL][ja] IIC T6, FNICO – non incendive ^① (probe can be used in flammable liquids) ATEX II 1 G Ex ia IIC T4 Ga, intrinsically safe ATEX II 1 G Ex ia IIC T4 Ga, FISCO – intrinsically safe ^① ATEX II 1/2 G Ex d[ja Ga] IIC T6 Gb ^② ATEX II 1/2 D Ex t[ja Da] IIC T85°C Db IP66 ^② IEC Ex d[ja Ga] IIC T6 Gb IEC Ex t[ja Da] IIC T85°C Db IP66 IEC Ex ia IIC T4 Ga, intrinsically safe IEC Ex ia IIC T4 Ga, FISCO – intrinsically safe ^① IEC Ex ic[ja Ga] IIC T4 Gc EN 12952-11 and EN 12953-9 CE approved for steam drums as primary level safety device TÜV – WHG § 63, VLAREM II 5.17-7 LRS – Lloyds Register of Shipping (marine applications) Other approvals are available, consult factory for more details
SIL ^③ (Safety Integrity Level)	Standard electronics	Functional safety to SIL 1 as 1oo1 / SIL 2 as 1oo2 in accordance to IEC 61508 – SFF of 84,5 %
	Enhanced electronics	Functional safety to SIL 2 as 1oo1 in accordance to IEC 61508 – SFF of 91 % Certified for use in SIL 3 loops.
Electrical Data		U _i = 28,4 V, I _i = 124 mA, P _i = 0,84 W (HART®) U _i = 17,5 V, I _i = 380 mA, P _i = 5,32 W (Foundation Fieldbus™ / Profibus PA™)
Equivalent Data		C _i = 2,2 nF, L _i = 3 μH (HART®) C _i = 3 nF, L _i = 3 μH (Foundation Fieldbus™ / Profibus PA™)
Shock/Vibration Class		ANSI/ISA-S71.03 Class SA1 (Shock), ANSI/ISA-S71.03 Class VC2 (Vibration)
Surge protection		Meets CE EN 61326 (1000V)
Net weight	Cast aluminium	2,7 kg (6.0 lbs) – transmitter head / electronics only
	Stainless steel	5,7 kg (12.6 lbs) – transmitter head / electronics only
Overall Dimensions		H 214 mm (8.43") x W 111 mm (4.38") x D 188 mm (7.40")
Foundation Fieldbus™ specifications	ITK Version	5.0
	H1 Device Class	Link Master (LAS) – selectable ON/OFF
	Function Blocks	1 x RB, 4 x AI, 1 x TB and 1 x PID
	Execution time	AI = 15 ms, PID = 40 ms
	Quiescent current draw	15 mA
	DD/CFF files	Available at www.fieldbus.org
Profibus PA specifications	Device revision	0x01
	Digital communication protocols	Version 3.0 MBP (31.25 kbits/sec)
	Function Blocks	1 x PB, 4 x AI blocks, 1 x TB
	Execution time	15 ms
	Quiescent current draw	15 mA
	GSD files	Available at www.profibus.com

① Foundation Fieldbus™ and Profibus PA™ units.

② For ATEX flameproof enclosure units use Ex d bushing material STYCAST 2057 FR.

③ Not applicable for Foundation Fieldbus™ and Profibus PA™ units.

PERFORMANCE

Description		Specification
Reference Conditions with a 1,8 m (72") coaxial type GWR probe		Reflection from liquid, with dielectric in center of selected range, at +20 °C (70 °F) with CFD threshold ^①
Linearity ^②	Coaxial/twin lead probes	< 0,1 % of probe length or 2,5 mm (0.1"), whichever is greater
	Single lead probes	< 0,3 % of probe length or 8 mm (0.3"), whichever is greater
Accuracy ^②	Coaxial/twin lead probes	< 0,1 % of probe length or 2,5 mm (0.1"), whichever is greater
	Single lead probes	± 0,5 % of probe length or 13 mm (0.5"), whichever is greater
	7MT/7ML interface	± 25 mm (1")
Resolution		± 2,5 mm (0.1")
Repeatability		< 2,5 mm (0.1")
Hysteresis		< 2,5 mm (0.1")
Response Time		< 1 second
Warm-up Time		< 5 seconds
Ambient Temp.		-40 °C to +80 °C (-40 °F to +175 °F) – blind transmitter -20 °C to +70 °C (-5 °F to +160 °F) – with digital display -40 °C to +70 °C (-40 °F to +160 °F) – for Ex ia and Ex d[ia] with blind transmitter -20 °C to +70 °C (-5 °F to +160 °F) – for Ex ia and Ex d[ia] with digital display
Process Dielectric Effect		< 7,5 mm (0.3") within selected range
Operating Temp. Effect		Approx. +0,02 % of probe length/°C for probes ≥ 2,5 m (8") ^③
Humidity		0-99 %, non-condensing
Electromagnetic Compatibility		Meets CE requirements (EN 61326: 1997 + A1 + A2) and NAMUR NE 21 (Single and Twin-Rod probe must be used in metallic vessel or stillwell)

PROBE SPECIFICATIONS

Description		7MR/7MM: overfill protection coaxial probe
Materials	Probe	316/316L (1.4401/1.4404), Hastelloy® C (2.4819) or Monel® (2.4360)
	Process seal	Teflon® with Viton® GFLT, Aegis PF 128 or Kalrez® 4079 (consult factory for alternatives)
	Spacers	Teflon®
Probe diameter		Inside rod 8 mm (0.315") – outer tube 22,5 mm (0.88")
Mounting		External cage and/or in-tank mounting
Process Connection		Threaded: 3/4" NPT or 1" BSP (G 1") Flanged: various ANSI, EN (DIN) or torque tube mating flanges
Probe length		From 60 cm to 610 cm (24" to 240")
Transition Zone ^④	Top	0 mm (0")
	Bottom	εr: 1,4 = 150 mm (6") / εr: 80 = 25 mm (1")
Process Temp. ^⑤	Max	+200 °C @ 18,6 bar (+400 °F @ 270 psi)
	Min	-40 °C @ 51,7 bar (-40 °F @ 750 psi)
Max. Process Pressure ^⑤		70 bar @ +20 °C (1000 psi @ +70 °F)
Max. Viscosity		500 mPa.s (cP)
Dielectric Range		1,4 to 100
Vacuum Service		Negative pressure but not hermetic seal
Media coating		In case of media coating, select 7MM probe

Description		7MD/7ML: high pressure / high temperature GWR probe
Materials	Probe	316/316L (1.4401/1.4404), Hastelloy® C (2.4819) or Monel® (2.4360)
	Process seal	Borosilicate / Inconel® X-750
	Spacers	7Mx-A, B and C: Ceramic 7Mx-W: Teflon® 7Mx-V: High Temp PEEK
Probe diameter		Inside rod 8 mm (0.315") – outer tube 22,5 mm (0,88")
Mounting		External cage and/or in-tank mounting
Process Connection		Threaded: 3/4" NPT or 1" BSP (G 1") Flanged: various ANSI, EN (DIN) or torque tube mating flanges
Probe length		From 60 cm to 610 cm (24" to 240")
Transition Zone ^④	Top	0 mm (0")
	Bottom	εr: 1,4 = 150 mm (6") / εr: 80 = 25 mm (1")
Process Temp. ^⑤	Max	+425 °C @ 103 bar (+800 °F @ 1500 psi) for 7Mx-A, B and C +345 °C @ 324 bar (+650 °F @ 4700 psi) for 7Mx-V +200 °C @ 393 bar (+400 °F @ 5700 psi) for 7Mx-W
	Min	-196 °C @ 138 bar (-320 °F @ 2000 psi)
Max. Process Pressure ^⑤		431 bar @ +20 °C (6250 psi @ +70 °F)
Max. Viscosity		500 mPa.s (cP)
Dielectric Range		1,4 to 100 for 7Mx-W 1,7 to 100 for 7Mx-V 2,0 to 100 for 7Mx-A, B and C
Vacuum service		Full vacuum (Helium leak < 10 ⁻⁹ cc/s @ 1 atmosphere vacuum)
Media coating		In case of media coating, select 7ML probe

① May degrade for 7MD/7ML probe or with fixed threshold.

② Top 600 mm (24") of twin rod probe: 30 mm (1.18").

Top 1220 mm (48") of single rod: application dependant.

Accuracy may degrade when using compensation.

③ Accuracy may degrade slightly < 2,5 m (8")

④ Transition Zone (zone with reduced accuracy) is dielectric dependent; εr = dielectric permittivity. It is recommended to set 4-20 mA signal outside transition zones.

⑤ See graphs at page 26 and 27.

Description		7MS: saturated steam GWR probe	7MQ: saturated steam GWR probe
Materials	Probe	316/316L (1.4401/1.4404)	
	Process seal	High Temp PEEK with Aegis PF 128	High Temp PEEK with Aegis PF 128 Alumina
	Spacers	High Temp PEEK	Silicon nitride
Probe diameter		Inside rod 8 mm (0.315) – outer tube 22,5 mm (0,88")	Inside rod 8 mm (0.315) – outer tube 32 mm (1,25")
Mounting		External cage and/or in-tank mounting	
Process Connection		Threaded: 3/4" NPT or 1" BSP (G 1") Flanged: various ANSI, EN (DIN) or torque tube mating flanges	Threaded: not available Flanged: various ANSI, EN (DIN) or torque tube mating flanges
Probe length		From 60 cm to 450 cm (24" to 177")	
Transition Zone ^①	Top	200 mm (8"); consult factory for overfill applications	
	Bottom	$\epsilon_r \geq 10 = 25 \text{ mm (1")}$	
Process Temp. ^②	Max	+300 °C @ 88 bar (+575 °F @ 1275 psi)	+345 °C @ 155 bar (+650 °F @ 2250 psi)
	Min	-15 °C @ 207 bar (0 °F @ 3000 psi)	
Max. Process Pressure ^②		88 bar @ +300 °C (1275 psi @ +575 °F)	155 bar @ +345 °C (2250 psi @ +650 °F)
Max. Viscosity		500 mPa.s (cP)	
Dielectric Range		10 to 100	
Vacuum service		Negative pressure but not hermetic seal	
Media coating		Not applicable	

Description		7MT/7MN: interface GWR probe	7MB: standard twin rod GWR probe
Materials	Probe	316/316L (1.4401/1.4404), Hastelloy® C (2.4819) or Monel® (2.4360)	
	Process seal	Teflon® with Viton® GFLT, Aegis PF 128 or Kalrez® 4079 (consult factory for alternatives)	
	Spacers	Teflon®	
Probe diameter		Inside rod 8 mm (0.315") – outer tube 22,5 mm (0,88")	Two 13 mm (0.5") Ø rods – 22,2 mm (0.875") ϕ to ϕ
Mounting		External cage and/or in-tank mounting	In-tank mounting only. Twin rod probe must be used in metallic vessel or stillwell > 25 mm (1") from any surface or obstruction.
Process Connection		Threaded: 3/4" NPT or 1" BSP (G 1") Flanged: various ANSI, EN (DIN) or torque tube mating flanges	Threaded: 2" NPT or 2" BSP (G 2") Flanged: various ANSI, EN (DIN) or torque tube mating flanges
Probe length		From 60 cm to 610 cm (24" to 240")	
Transition Zone ^①	Top	0 mm (0")	$\epsilon_r \geq 1,9 = 150 \text{ mm (6")}$
	Bottom	$\epsilon_r: 1,4 = 150 \text{ mm (6")}/\epsilon_r: 80 = 50 \text{ mm (2")}$	$\epsilon_r: 1,9 = 150 \text{ mm (6")}/\epsilon_r: 80 = 25 \text{ mm (1")}$
Process Temp. ^②	Max	+200 °C @ 18,6 bar (+400 °F @ 270 psi)	+150 °C @ 27,6 bar (+300 °F @ 400 psi)
	Min	-40 °C @ 51,7 bar (-40 °F @ 750 psi)	
Max. Process Pressure ^②		70 bar @ +20 °C (1000 psi @ +70 °F)	
Max. Viscosity		500 mPa.s (cP)	1500 mPa.s (cP)
Dielectric Range		Upper liquid: $\geq 1,4$ and ≤ 5 Lower liquid: ≥ 15	1,9 to 100
Vacuum service		Negative pressure but not hermetic seal	
Media coating		In case of media coating, select 7MN probe	Film: 3% error of coated length, bridging not recommended ^③

① Transition Zone (zone with reduced accuracy) is dielectric dependent; ϵ_r = dielectric permittivity. It is recommended to set 4-20 mA signal outside transition zones.

② See graphs at page 26 and 27.

③ Bridging is defined as continuous accumulation of material between the probe elements.

Description		7MF: standard single rod	7MJ: HTHP single rod
Materials	Probe	316/316L (1.4401/1.4404), Hastelloy® C (2.4819), Monel® (2.4360), or PFA insulated 316/316L (1.4401/1.4404)	316/316L (1.4401/1.4404), Hastelloy® C (2.4819) or Monel® (2.4360)
	Process seal	TFE with Viton® GFLT, Aegis PF 128 or Kalrez® 4079 (consult factory for alternatives)	PEEK with Aegis PF 128
Probe diameter		Bare: 13 mm (0.50") - PFA coated: 16 mm (0.625")	Bare: 13 mm (0.50")
Mounting		See mounting considerations on page 15	
Process Connection		Threaded: 2" NPT or 2" BSP (G 2") Flanged: various ANSI or EN (DIN) flanges	
Probe length		From 60 cm to 610 cm (24" to 240")	
Blocking distance (top)		120 mm up to 910 mm (4.8" up to 36") - depending probe length (adjustable)	
Transition Zone ^① (bottom)		$\epsilon_r \geq 10$: 25 mm (1")	
Process Temp. ^②	Max	+150 °C @ 27,6 bar (+300 °F @ 400 psi)	+315 °C @ 155 bar (+600 °F @ 2250 psi)
	Min	7MF-F: -40 °C @ 13,8 bar (-40 °F @ 200 psi) Other 7MF-probes: -40 °C @ 51,7 bar (-40 °F @ 750 psi)	-15 °C @ 245 bar (0 °F @ 3550 psi)
Max Process Pressure ^②		70 bar @ +20 °C (1000 psi @ +70 °F)	245 bar @ +20 °C (3550 psi @ +70 °F)
Max Viscosity		10.000 mPa.s (cP) – consult factory in case of agitation/turbulence	
Dielectric Range		ϵ_r : 10-100 (depending installation conditions, down to $\epsilon_r \geq 1,9$)	
Vacuum service		Negative pressure but not hermetic seal	
Media coating		Max error of 10 % of coated length. % Error is related to dielectric of medium, thickness of coating and coated probe length above level.	

Description		7M1 (liquids) / 7M2 (solids): single flexible	7M5 (solids) / 7M7 (liquids): twin flexible
Materials	Probe	316 SST (1.4401)	FEP coated 316 SST (1.4401)
	Process seal	7M1/7M7: Teflon® with Viton® GFLT, Aegis PF 128 or Kalrez® 4079 (consult factory for alternatives) 7M2/7M5: Teflon® with Viton® GFLT	
Probe diameter		7M1: 5 mm (0.19") 7M2: 6 mm (0.25")	6 mm (0.25")
Mounting		See mounting considerations on page 15	
Process Connection		Threaded: 2" NPT or 2" BSP (G 2") Flanged: various ANSI or EN (DIN) flanges	
Probe length		From 2 m (6.56') to max 22 m (72.18')	
Blocking distance (top)		120 mm up to 910 mm (4.8" up to 36") - depending probe length (adjustable)	300 mm to 500 mm (12" to 20")
Transition Zone ^① (bottom)		305 mm (12")	
Process Temp. ^②	Max	7M1/7M7: +150 °C @ 27,6 bar (+300 °F @ 400 psi) 7M2/7M5: +65 °C @ 3,45 bar (+150 °F @ 50 psi)	
	Min	7M1/7M7: -40 °C @ 51,7 bar (-40 °F @ 750 psi) 7M2/7M5: -40 °C @ 3,45 bar (-40 °F @ 50 psi)	
Max Process Pressure ^②		7M1/7M7: 70 bar @ +20 °C (1000 psi @ +70 °F) 7M2/7M5: 3,45 bar @ +20 °C (50 psi @ +70 °F)	
Max Viscosity		10.000 mPa.s (cP) – consult factory in case of agitation/ turbulence	1500 mPa.s (cP)
Dielectric Range		7M1: ϵ_r : 10-100 (depending installation conditions, down to $\epsilon_r \geq 1,9$) 7M2: ϵ_r : 4-100	ϵ_r : 1,9-100
Mechanical load		7M1: 9 kg (20 lbs)	
Pull-down force		7M2: 1360 kg (3000 lbs)	7M5: 1360 kg (3000 lbs)
Vacuum service		Negative pressure but not hermetic seal	
Media coating		Max error of 10 % of coated length. % Error is related to dielectric of medium, thickness of coating and coated probe length above level.	

① Transition Zone (zone with reduced accuracy) is dielectric dependent; ϵ_r = dielectric permittivity. It is recommended to set 4-20 mA signal outside the transition zone / blocking distance.

② See graphs at page 26 and 27.

TEMPERATURE-PRESSURE RATING FOR ECLIPSE PROBE SEALS

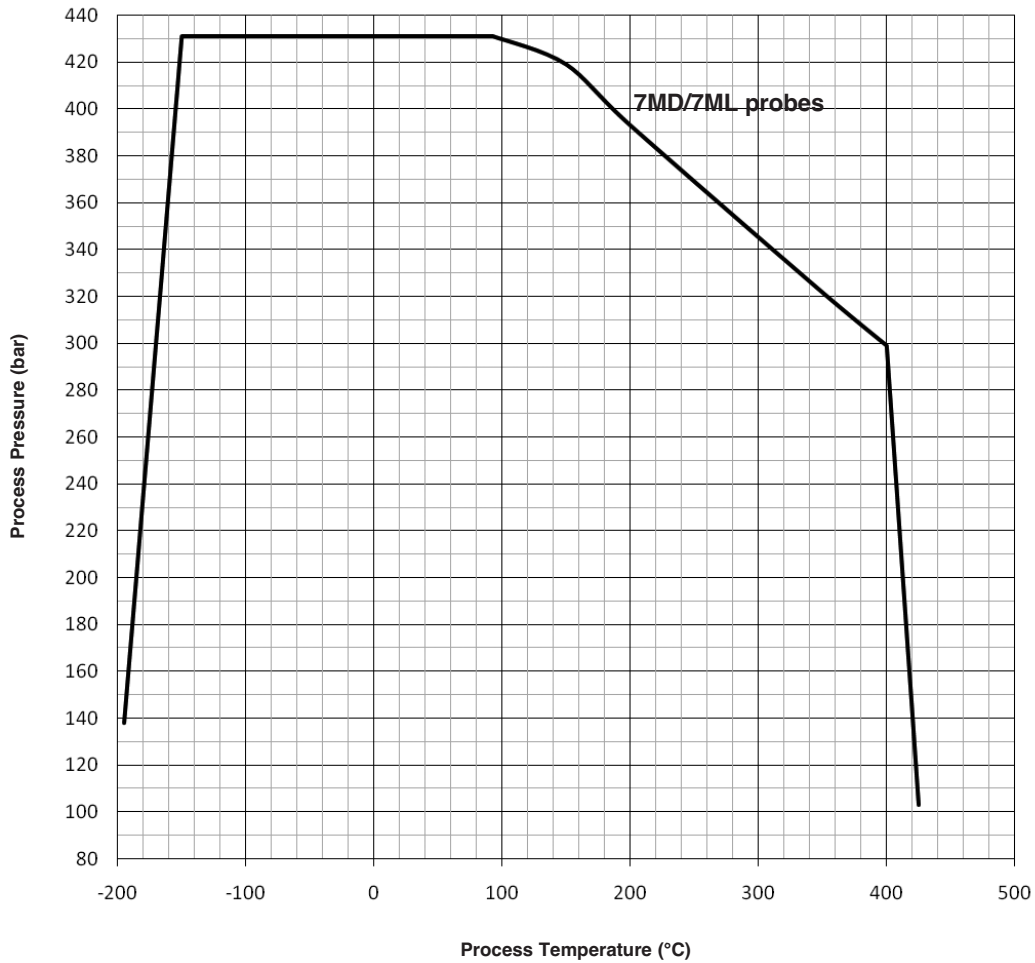
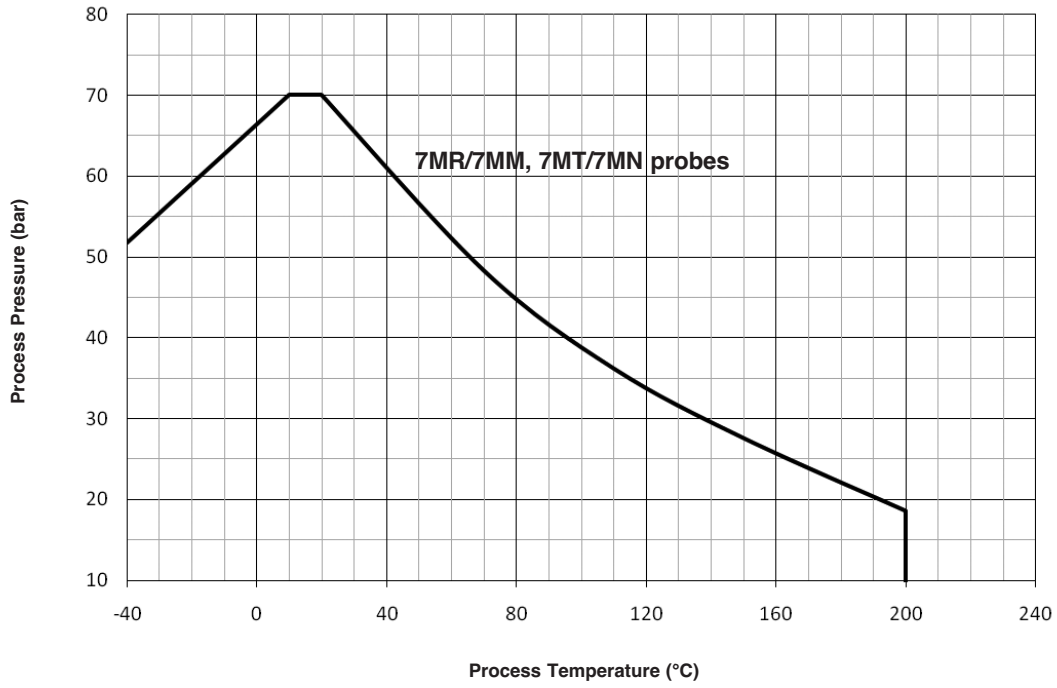

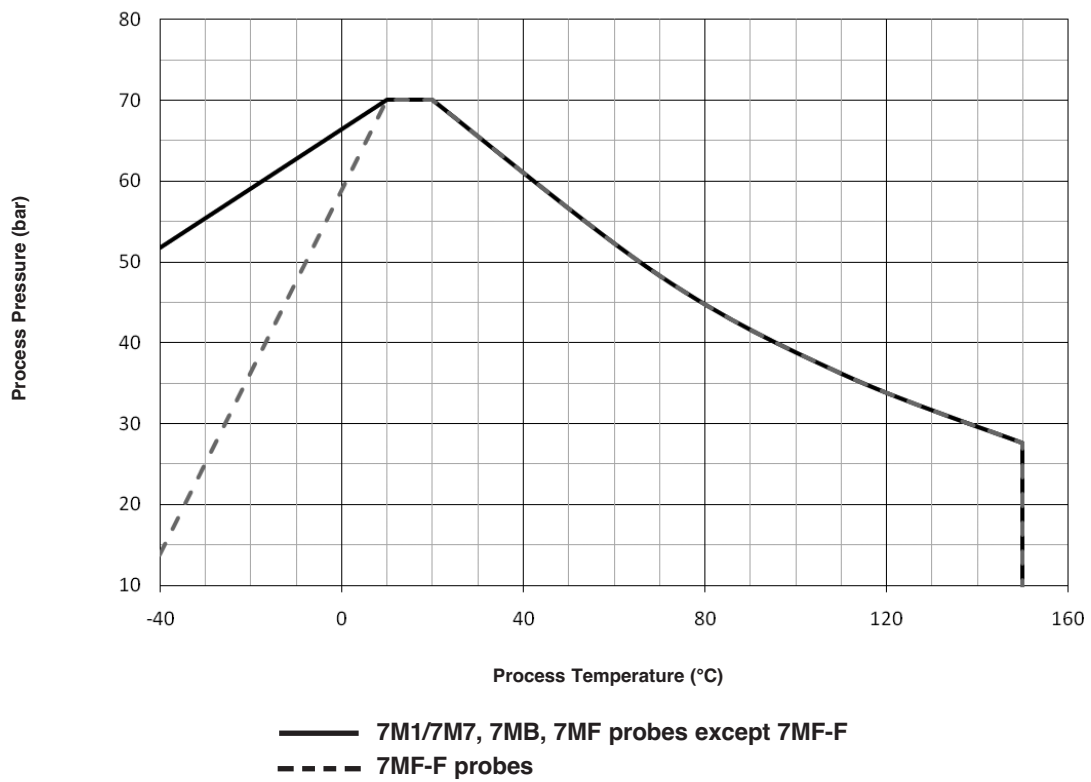
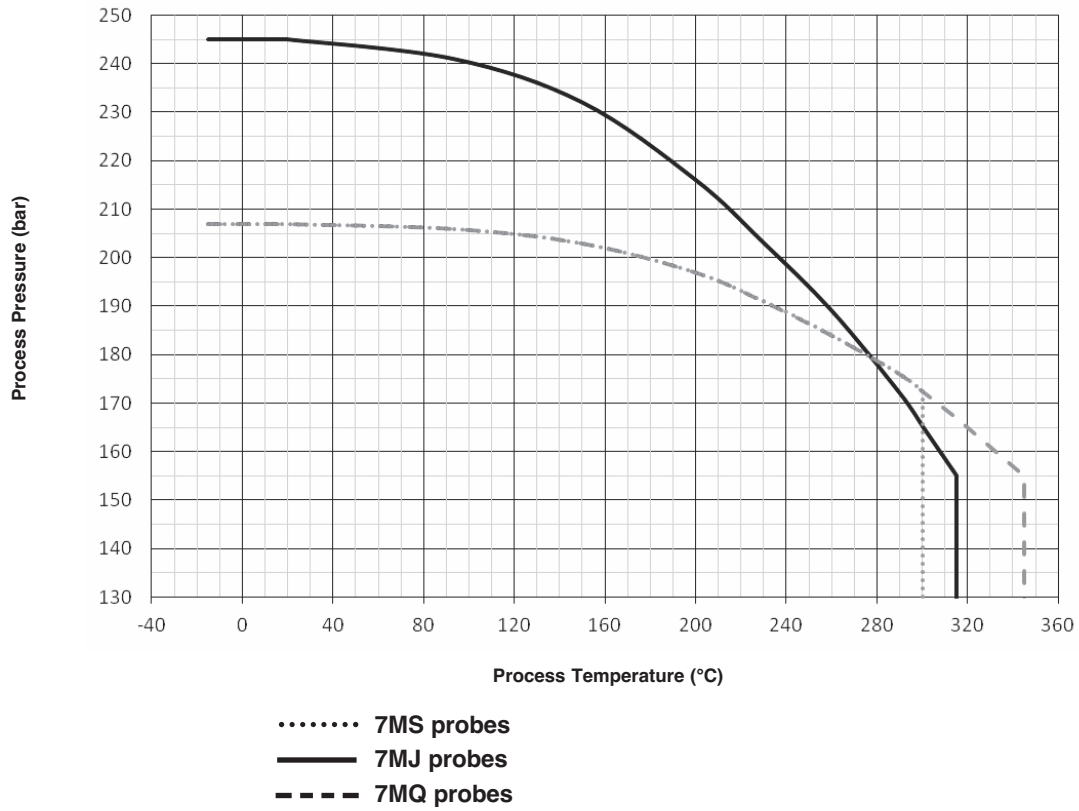



QUALITY ASSURANCE - ISO 9001:2008

THE QUALITY ASSURANCE SYSTEM IN PLACE AT MAGNETROL GUARANTEES THE HIGHEST LEVEL OF QUALITY DURING THE DESIGN, THE CONSTRUCTION AND THE SERVICE OF CONTROLS. OUR QUALITY ASSURANCE SYSTEM IS APPROVED AND CERTIFIED TO **ISO 9001:2008** AND OUR TOTAL COMPANY IS COMMITTED TO PROVIDING FULL CUSTOMER SATISFACTION BOTH IN QUALITY PRODUCTS AND QUALITY SERVICE.

PRODUCT WARRANTY

ALL MAGNETROL ELECTRONIC AND ULTRASONIC LEVEL CONTROLS ARE WARRANTED FREE OF DEFECTS IN MATERIALS AND WORKMANSHIP FOR ONE FULL YEAR FROM THE DATE OF ORIGINAL FACTORY SHIPMENT. IF RETURNED WITHIN THE WARRANTY PERIOD; AND, UPON FACTORY INSPECTION OF THE CONTROL, THE CAUSE OF THE CLAIM IS DETERMINED TO BE COVERED UNDER THE WARRANTY; THEN, MAGNETROL INTERNATIONAL WILL REPAIR OR REPLACE THE CONTROL AT NO COST TO THE PURCHASER (OR OWNER) OTHER THAN TRANSPORTATION. MAGNETROL SHALL NOT BE LIABLE FOR MISAPPLICATION, LABOR CLAIMS, DIRECT OR CONSEQUENTIAL DAMAGE OR EXPENSE ARISING FROM THE INSTALLATION OR USE OF THE EQUIPMENT. THERE ARE NO OTHER WARRANTIES EXPRESSED OR IMPLIED, EXCEPT, SPECIAL WRITTEN WARRANTIES COVERING SOME MAGNETROL PRODUCTS.



BULLETIN N°: BE 57-101.22
EFFECTIVE: SEPTEMBER 2015
SUPERSEDES: June 2013

UNDER RESERVE OF MODIFICATIONS

BENELUX FRANCE	Heikensstraat 6, 9240 Zele, België -Belgique Tel. +32 (0)52.45.11.11 • Fax. +32 (0)52.45.09.93 • E-Mail: info@magnetrol.be
DEUTSCHLAND	Alte Ziegelei 2-4, D-51491 Overath Tel. +49 (0)2204 / 9536-0 • Fax. +49 (0)2204 / 9536-53 • E-Mail: vertrieb@magnetrol.de
INDIA	B-506, Sagar Tech Plaza, Saki Naka Junction, Andheri (E), Mumbai - 400072 Tel. +91 22 2850 7903 • Fax. +91 22 2850 7904 • E-Mail: info@magnetrolindia.com
ITALIA	Via Arese 12, I-20159 Milano Tel. +39 02 607.22.98 • Fax. +39 02 668.66.52 • E-Mail: mit.gen@magnetrol.it
RUSSIA	198095 Saint-Petersburg, Marshala Govorova street, house 35A, office 427 Tel. +7 812 320 70 87 • E-Mail: info@magnetrol.ru
U.A.E.	DAFZA Office 5EA 722 • PO Box 293671 • Dubai Tel. +971-4-6091735 • Fax +971-4-6091736 • E-Mail: info@magnetrol.ae
UNITED KINGDOM	Unit 1 Regent Business Centre, Jubilee Road Burgess Hill West Sussex RH 15 9TL Tel. +44 (0)1444 871313 • Fax +44 (0)1444 871317 • E-Mail: sales@magnetrol.co.uk

www.magnetrol.com

OUR NEAREST REPRESENTATIVE