

A Higher Level of Performance



Data Sheet

Gladiator

Admittance Smart Switch Series

An All-round Point Level Switch

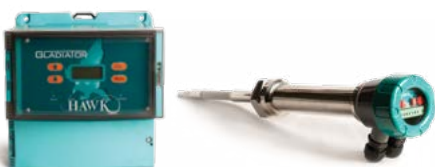

For more information, please visit >
www.hawkmeasure.com

Overview

Gladiator Admittance Smart Switch Series



The **Gladiator Admittance Smart Switch Series** is a third generation, state-of-the-art level probe, designed to operate in tough industrial environments.

Principle of Operation

The probe of the Admittance Switch forms one plate of a capacitance circuit, with the vessel wall making the second plate. The dielectric constant of the product between the probe and the vessel wall will cause a change of capacitance as the level approaches the probe. The change is detected, amplified and used to switch a relay for indication or control purposes. A special circuit is used to ignore product build-up between the sensing probe (active element) and guard, and also between the guard and vessel wall.

Typical Uses

- Failsafe high-level / low-level alarm
- High-level alarm
- Low-level alarm
- Blocked chute / Plugged chute
- Interface detection
- Pump control.

Function

The Gladiator Admittance Smart Switch is point level switch for liquids, solids and powders. The unit is suitable for a broad range of products and dielectric constants up to high temperature of 450°C (842°F).

Primary Areas of Application

- Asphalt
- Mining & Metals
- Semiconductor
- Brewing
- Oil & Gas
- Sugar
- Cement
- Packaging
- Textile
- Chemical
- Paint
- Water & Wastewater.
- Dairy
- Paper
- Edible oil
- Pharmaceutical
- Fertilizer
- Plastics
- Food & Beverage
- Power Generation
- Glass
- Refining

Features

- Excellent immunity to product build-up
- Excellent temperature stability - no false trips
- Non contact switching possible with many products
- Simple '1-minute' setup
- Remote sensor or Integral 'all in one' types
- Relay outputs: Integral probe (1) Remote (2)
- Remote test function
- Adjustable ON and OFF delays (0-20 sec)
- Remote 3G Connection option
- Remote amplifier to probe separation up to 500 meters (1640 ft)
- Bright visual status indication on Probe
- Independent housing alignment after mounting thread locked.

Typical Applications

Gladiator Admittance Smart Switch Series



High and low-level switch in a hopper

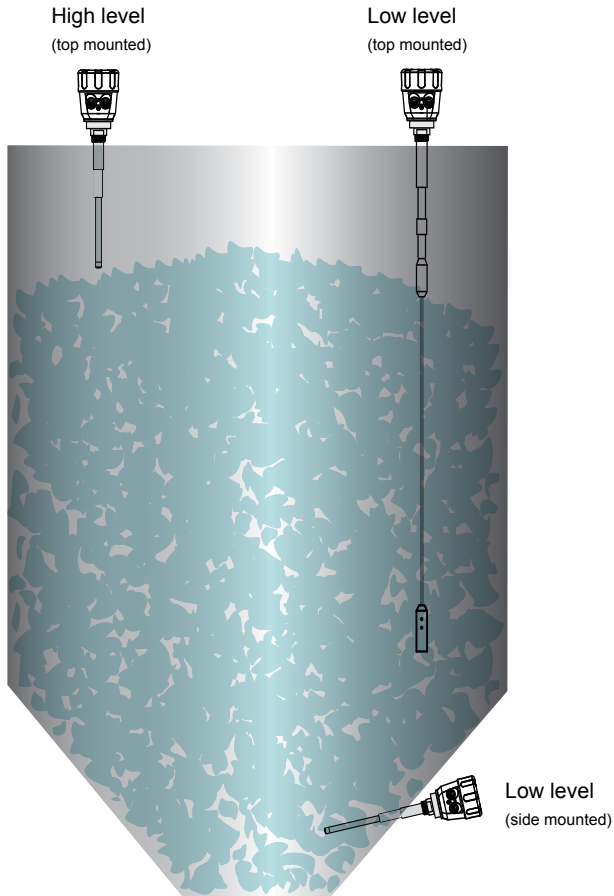

Cyclone bin level switch

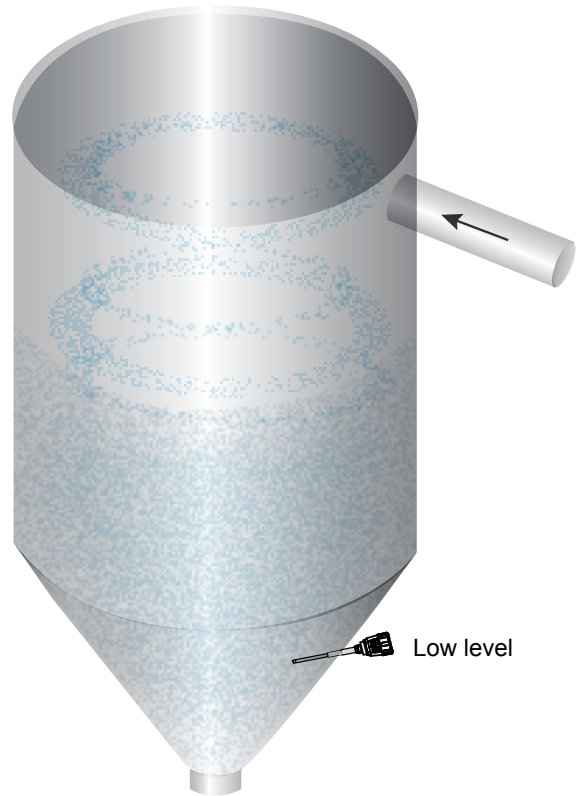

Presence / Absence of liquid in pipe detection

Sealing plug available allowing removal of unit without pipe leakage

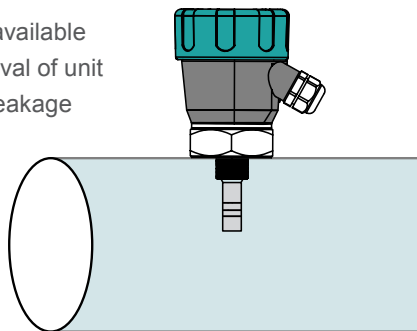

High level switch in grain application



Continuous filling with build-up on probe



Dimensions

Gladiator Admittance Smart Switch Series



Flexible Cable Probe

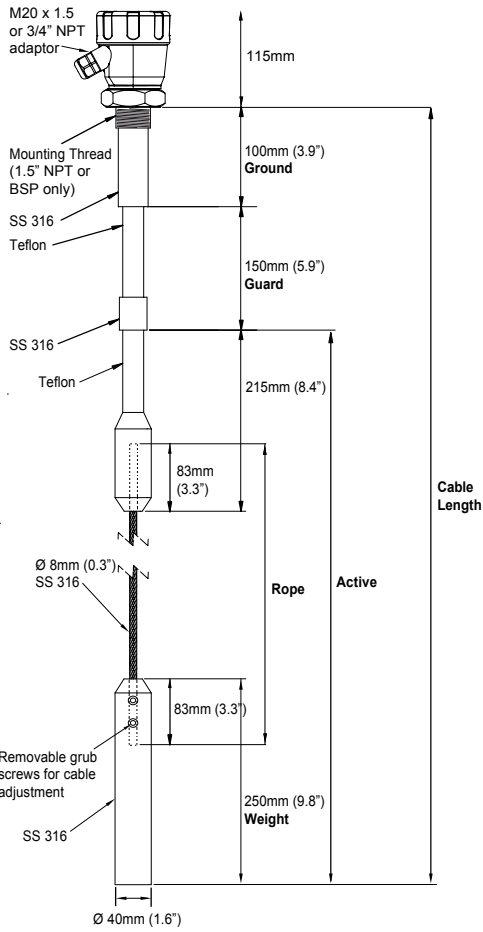

Probe Length (mm, inch)	Active	+ Guard + Ground	(Rope Length)
C100 (1000mm, 39.3")	= 750mm, 29.5"	+ 250mm, 9.8"	451mm, 17.8"
C200 (2000mm, 78.7")	= 1750mm, 68.9"	+ 250mm, 9.8"	1451mm, 57.1"
C300 (3000mm, 118.1")	= 2750mm, 108.3"	+ 250mm, 9.8"	2451mm, 96.5"

Remote Probe

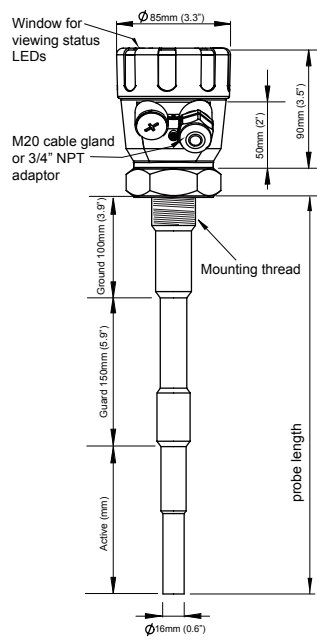

Integral Probe

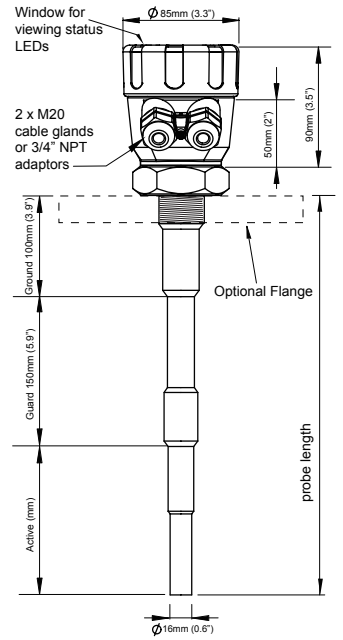

Probe Length (mm, inch)	Active	+ Guard + Ground
P05 (50mm, 2")	= 15mm, 0.6"	+ 35mm, 1.4"
P30 (300mm, 11.8")	= 50mm, 2"	+ 250mm, 9.8"
P50 (500mm, 19.7")	= 250mm, 9.8"	+ 250mm, 9.8"
P100 (1000mm, 39.4")	= 750mm, 29.5"	+ 250mm, 9.8"

Pump Protection Probe

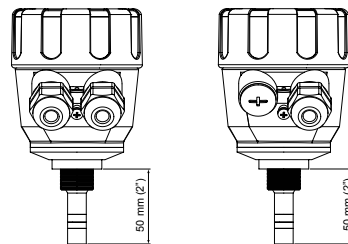

Sealing Cover

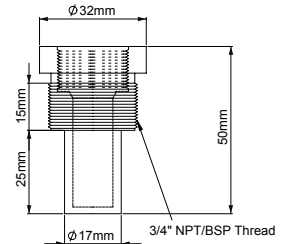

Remote Amplifier

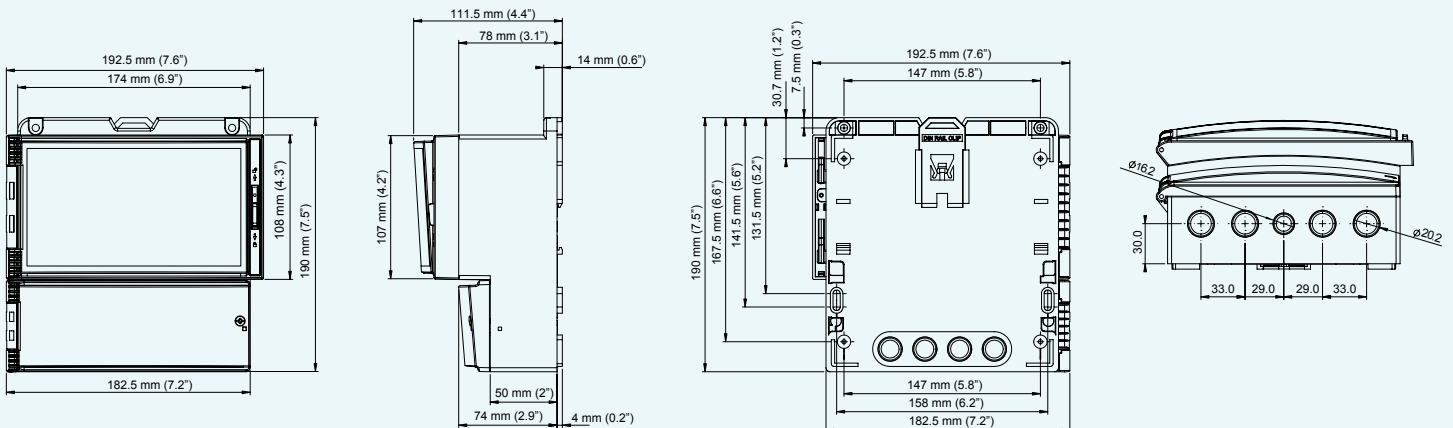

Dimensions

Gladiator Admittance Smart Switch Series



High Temperature Probe (<250°C, <482°F)

High Temperature Probe (450°C, 842°F)

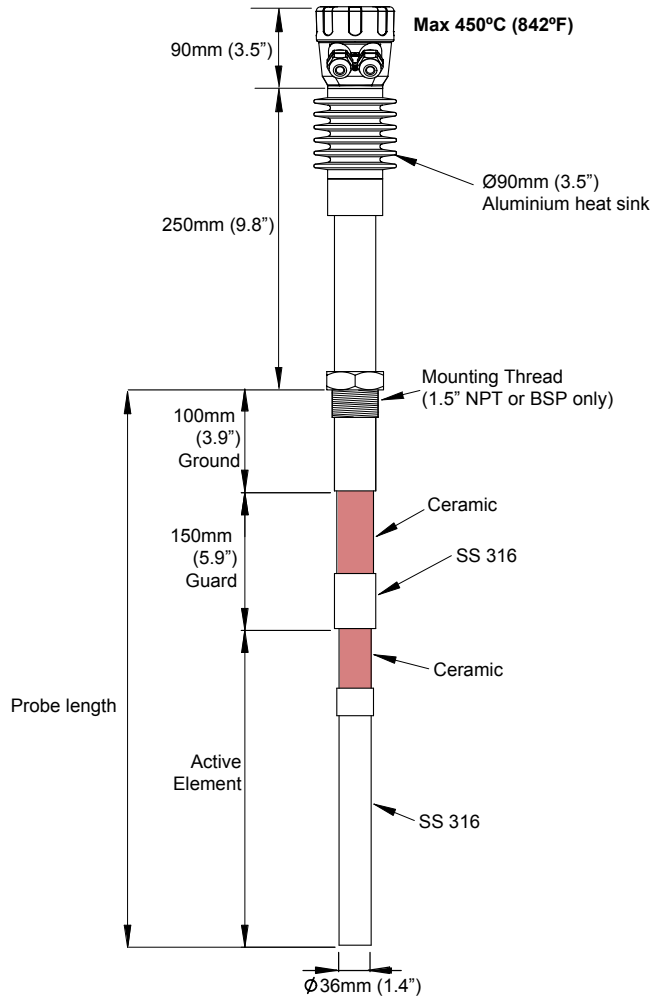
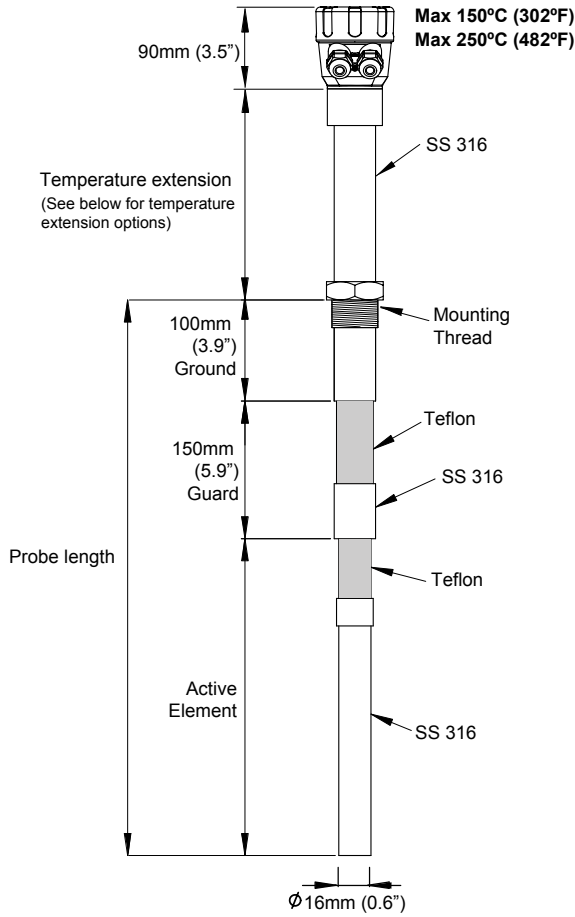

Optional Flange

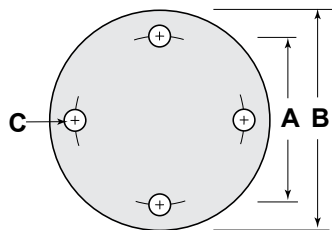

High Temperature Extensions (<250°C, 482°F)

Flange Dimensions - 50mm (2")

	A	B	C
ANSI (Class 150)	120.7 4.75"	152.4 6"	19.1 0.75"
DIN (PN40)	125 4.9"	165 6.5"	18 0.7"
JIS (10K)	120 4.7"	155 6.1"	19 0.75"

Remote Probe or Integral Probe

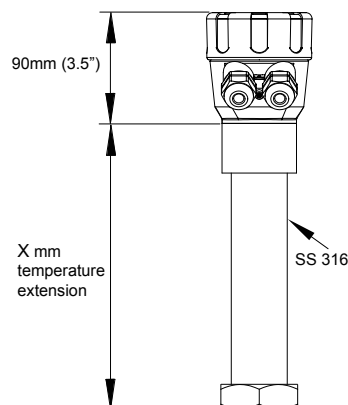

X mm:

- Max. 80°C (176°F) ~ no temperature extension required.
- Max. 150°C (302°F) ~ 150mm (5.9")
- Max. 250°C (482°F) ~ 250mm (9.8")
- For the 450°C (842°F) Probe, a different extension applies.



Integral Probe Wiring

Remove Plug-In terminal block for easier wiring.

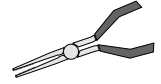
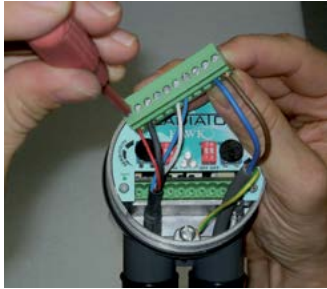

Use long nose pliers to extract terminal



The AC earth/ground cable must be connected to the ground screw inside the housing when using AC power.

Hole for securing of optional identification tag

M4 grounding screw

If only one cable is used for both power and output signal, then the second entry port must be plugged or blinded. Every Smart unit is supplied with two M20 glands (or 3/4" NPT adaptors) mounted on the unit and one blind plug loose.

Ground the housing to vessel, if vessel is metallic. Ground the housing to plant ground, if vessel is non-metallic.



Terminal Layout - Output Option S (SPDT)

RELAY				COMMS		DC-IN		AC-IN	
1.	2.	3.	4.	5.	6.	7.	8.	9.	10.
NC	COM	NO	Test	A	B	+	-	N	L1
				RS 485		12-30Vdc		80-265Vac	

Terminal Layout - Output Option D (DPDT)

RELAY						DC-IN		AC-IN	
1.	2.	3.	4.	5.	6.	7.	8.	9.	10.
NC1	COM1	NO1	NC2	COM2	NO2	+	-	N	L1
						7-30Vdc		80-265Vac	



Remote Probe to Amplifier Wiring

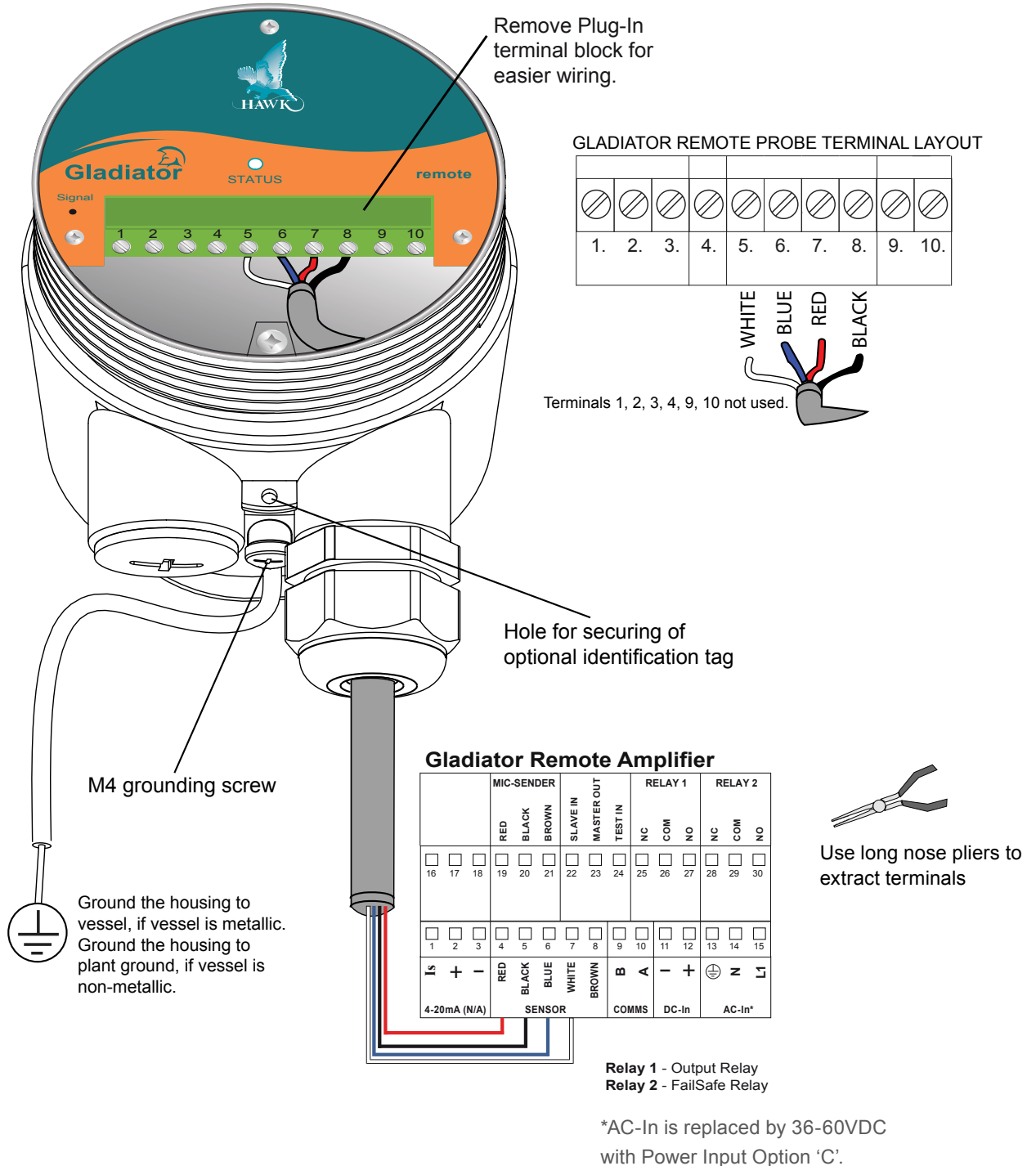

Cable type between Amplifier and Probe

- Cable type between Amplifier and Probe
- 4 conductor shielded twisted pair instrument cable
- Conductor size dependent on cable length
- BELDEN 3084A, DEKORON or equivalent
- Max: BELDEN 3084A = 500m (1640 ft)
- Max: DEKORON IED183AA002 = 350m (1150 ft).

Mounting Examples

Gladiator Admittance Smart Switch Series



Mounting

Probes can be mounted from above or from the side.

Use a protection plate for side mounting where the probe may be subject to impact damage.

Install the Probe far enough away from the vessel wall to prevent the probe from coming into contact with the wall, and prevent build-up of product from bridging the probe to the wall over time.

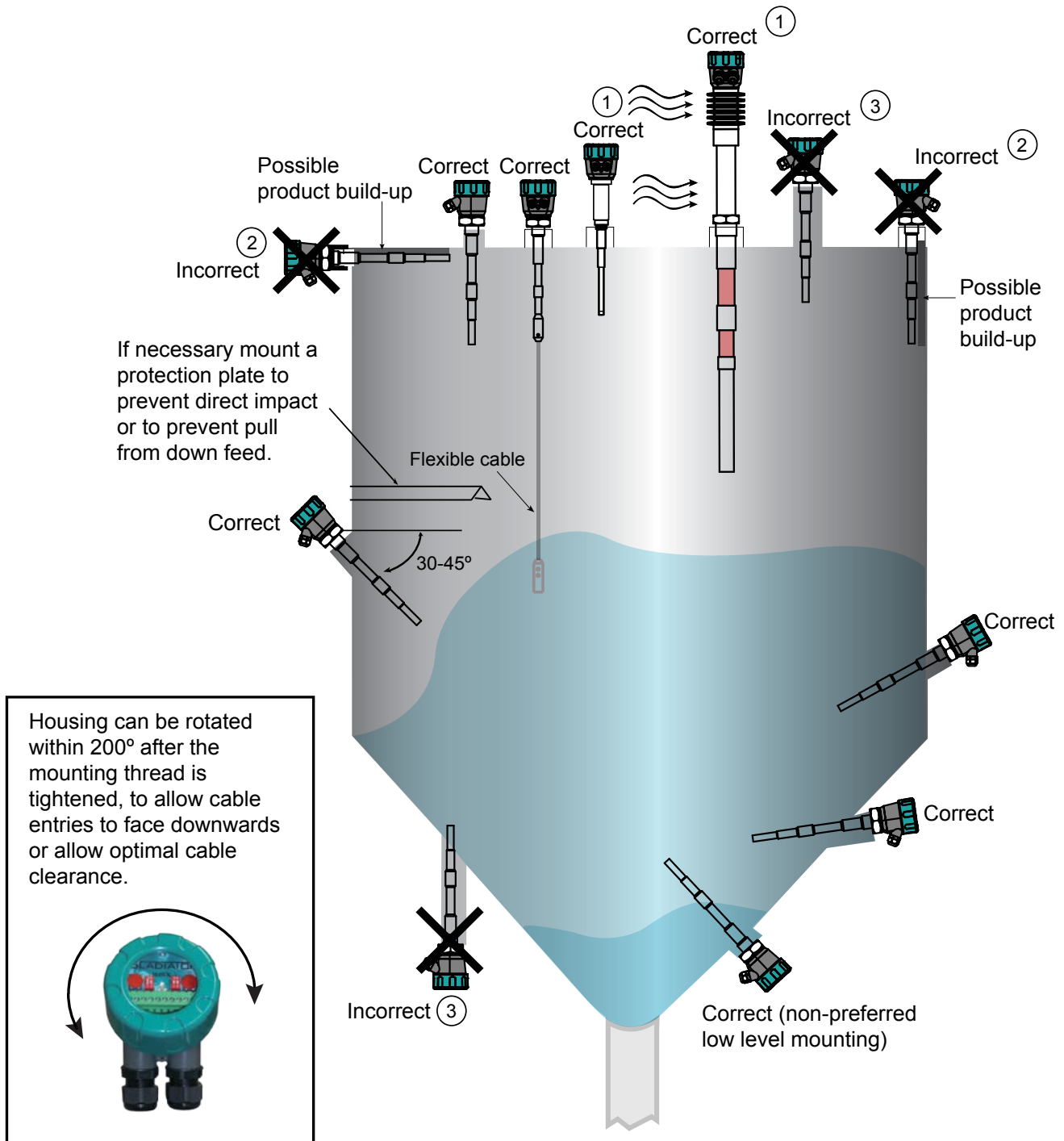



Integral Probe Version

AS2100 Gladiator Admittance Switch - Integral Probe

Power Supply

- B 12-30 VDC
- U 12-30VDC and 90-260VAC

Output Options

- S 1 x SPDT Relay, Modbus
- D 1 x DPDT Relay, Modbus

Housing

- S Powder Coated Aluminium
- C 316L Stainless Steel

Guard Length (excludes 100mm ground length)

- 1 150 mm (5.9")

Temperature

- 1 Max. 80°C (176°F)
- 2 Max. 150°C (302°F)
- 3 Max. 250°C (482°F)
- 4 Max. 450°C (842°F) (1.5" mounting thread only)

Probe Type

- 1 316L rod
- 2 Teflon Insulated 316L rod
- 3 Cable

Mounting

- TN07 3/4" NPT Thread
- TB07 3/4" BSP Thread
- TN10 1" NPT Thread
- TB10 1" BSP Thread
- TN15 1.5" NPT Thread
- TB15 1.5" BSP Thread
- FA2 2" ANSI SS Flange (Class 150)
- FD2 DIN50 SS Flange (PN 40)

Approvals (see Approvals Table)²

- X Not Required
- A20A
- A20
- i20A
- i20
- A22

(P)Probe³ (C)Cable Length

- P10 100mm (4")
- P30 300mm (11.8")
- P50 500mm (19.6")
- P100 1000mm (39.3")
- C100 1000mm (39.3")
- C200 2000mm (78.7")
- C300 3000mm (118.1")
- C500 5000mm (196.9")

²Approvals Table

A20A (Open Vessel)
ATEX Grp II Cat 1/2 D Ex iaD A20 IP65 T100°C for Tamb -20°C to 80°C
A20 (Closed Vessel)
(Internal of Vessel) ATEX Grp II Cat 1/2 D Ex iaD A20 IP65 T100°C
(External of Vessel) ATEX Grp II Cat 1/2 D Ex iaD A20 IP65 T100°C for Tamb -20°C to 80°C
i20A (Open Vessel)
IECEX Zone 20 (Ex iaD tD A20 IP65 T100°C Ta -20°C to 80°C)
i20 (Closed Vessel)
(Internal of Vessel) IECEX Zone 20 (Ex iaD 20 IP65 T100°C Ta -20°C to 80°C)
(External of Vessel)
IECEX Zone 21 (Ex iaD A21 IP65 T100°C Ta -20°C to 80°C)
A22
ATEX Grp II Cat 3 GD T75°C IP67 Tamb -40°C to 65°C

Some Approvals may require Intrinsically Safe Barriers.
Consult Safety Instructions for further information

³Custom lengths available. Consult Factory

AS2100 B S S 1 1 1 TB15 X P30

Part Numbering

Gladiator Admittance Smart Switch Series



Remote Version

Remote Amplifier

GSA Remote Gladiator System Amplifier

Housing

S Polycarbonate

Power Supply

B 12-30 VDC

C 36-60VDC

U 12-30VDC and 90-260VAC

Output Options (inc. Modbus)

S 2 x SPDT, 1 level relay, 1 failsafe relay

Approvals

X Not Required

A22 ATEX Grp II Cat 3 GD T75°C IP67

Tamb -40°C to 65°C

GSA S U S

Connection Cable

CA-GMR Pre-cut cable for remote system

10 10m cable

20 20m cable

30 30m cable

50 50m cable

100 100m cable

CA-GMR 10

Lengths above 100m available via special order

²Approvals Table

A20A (Open Vessel)

ATEX Grp II Cat 1/2 D Ex iaD A20 IP65 T100°C for Tamb -20°C to 80°C

A20 (Closed Vessel)

(Internal of Vessel) ATEX Grp II Cat 1/2 D Ex iaD A20 IP65 T100°C

(External of Vessel) ATEX Grp II Cat 1/2 D Ex iaD A20 IP65 T100°C for Tamb -20°C to 80°C

i20A (Open Vessel)

IECEX Zone 20 (Ex iaD tD A20 IP65 T100°C Ta -20°C to 80°C)

i20 (Closed Vessel)

(Internal of Vessel) IECEX Zone 20 (Ex iaD 20 IP65 T100°C Ta -20°C to 80°C)

(External of Vessel)

IECEX Zone 21 (Ex iaD A21 IP65 T100°C Ta -20°C to 80°C)

A22

ATEX Grp II Cat 3 GD T75°C IP67 Tamb -40°C to 65°C

Remote Probe

AS2200 Remote Gladiator Admittance Probe

Housing

S Powder Coated Aluminium

C 316L Stainless Steel

Guard Length (excludes 100mm ground length)

1 150 mm (5.9")

Temperature

1 Max. 80°C (176°F)

2 Max. 150°C (302°F)

3 Max. 250°C (482°F)

4 Max. 450°C (842°F) (1.5" mounting thread only)

Probe Type

1 316L rod

2 Teflon Insulated 316L rod

3 Cable

Mounting

TN07 3/4" NPT Thread

TB07 3/4" BSP Thread

TN10 1" NPT Thread

TB10 1" BSP Thread

TN15 1.5" NPT Thread

TB15 1.5" BSP Thread

FA2 2" ANSI SS Flange (Class 150)

FD2 DIN50 SS Flange (PN 40)

Approvals (see Approvals Table)²

X Not Required

A20

A20A

i20

i20A

A22

(P)Probe³ (C)Cable Length

P10 100mm (4")

P30 300mm (11.8")

P50 500mm (19.6")

P100 1000mm (39.3")

C100 1000mm (39.3")

C200 2000mm (78.7")

C300 3000mm (118.1")

C500 5000mm (196.9")

AS2200 S 1 1 1 TB15 X P30

³Custom lengths available. Consult Factory

Some Approvals may require Intrinsically Safe Barriers.
Consult Safety Instructions for further information



Pump Protection Version

AS2100 Gladiator Admittance Pump Protection Probe

Power Supply

- B 12-30 VDC
- U 12-30VDC and 90-260VAC

Output Options

- S 1 x SPDT Relay, Modbus
- D 1 x DPDT Relay, Modbus

Housing

- S Powder Coated Aluminium
- C 316L Stainless Steel

Guard Length

- 2 Short guard

Temperature

- 1 Max. 80°C (176°F)
- 2 Max. 150°C (302°F)
- 3 Max. 250°C (482°F)

Probe Type

- 1 316L rod

Mounting

- TB05 1/2" BSP thread
- TN05 1/2" NPT thread

Approvals (see Approvals Table)²

- X Not Required
- A20A
- A20
- i20A
- i20
- A22

(P)Probe Length

- P05 50mm

AS2100 B S S 1 1 1 TN05 X P05

²Approvals Table

A20A (Open Vessel)
ATEX Grp II Cat 1/2 D Ex iaD A20 IP65 T100°C for Tamb -20°C to 80°C
A20 (Closed Vessel)
(Internal of Vessel) ATEX Grp II Cat 1/2 D Ex iaD A20 IP65 T100°C
(External of Vessel) ATEX Grp II Cat 1/2 D Ex iaD A20 IP65 T100°C for Tamb -20°C to 80°C
i20A (Open Vessel)
IECEX Zone 20 (Ex iaD tD A20 IP65 T100°C Ta -20°C to 80°C)
i20 (Closed Vessel)
(Internal of Vessel) IECEX Zone 20 (Ex iaD 20 IP65 T100°C Ta -20°C to 80°C)
(External of Vessel) IECEX Zone 21 (Ex iaD A21 IP65 T100°C Ta -20°C to 80°C)
A22
ATEX Grp II Cat 3 GD T75°C IP67 Tamb -40°C to 65°C

Some Approvals may require Intrinsically Safe Barriers.
Consult Safety Instructions for further information

Specifications

Gladiator Admittance Smart Switch Series



Operating Voltage

- 12 - 30Vdc (residual ripple no greater than 100mV)
- 90 - 260Vac 50 / 60Hz.
- 36-60VDC.

Power Consumption

- <0.8W @ 24VDC
- <6W @ 48VDC
- <5VA @ 240VAC
- <3VA @ 115VAC

Communications

- GosHawk, Modbus
- Multidrop mode can address 1-250 units over 4 wires.

Relay Output: (1) Integral (2) Remote

- Remote: 2 x Form 'C' (SPDT) contacts, rated 5A at 240Vac resistive
- Integral: 1 x DPDT or 1 x SPDT rated 5A at 240Vac resistive
- Remote failsafe test facility for one relay (SPDT only)

Measurement Range

- 0.2pF - 100nF.

Resolution

- 0.01 pF.

Electronic Accuracy

- 0.05 pF.

Stability

- 0.01% / °C.

Operating Temperature

- Remote electronics -40°C (-40°F) to 80°C (176°F)
- Integral Probe -40°C (-40°F) to 450°C (842°F)*
- Remote Probe -40°C (-40°F) to 450°C (842°F)*.

*Correct temperature range probe must be specified when ordering.

Probe / Amplifier Separation

- Up to 500m (1640ft) using specified extension cable.

Cable type between Amplifier and Probe

- 4 conductor shielded twisted pair instrument cable.
- Conductor size dependent on cable length.
- BELDEN 3084A, DEKORON or equivalent.
- Max: BELDEN 3084A = 500m (1640 ft)
- Max: DEKORON IED183AA002 = 350m (1150 ft) .

Maximum Operating Pressure

- 10 BAR at 120 °C.

Display (Remote version only)

- 2 line x 12 character alphanumeric LCD
- Backlight standard.

Memory - Remote

- Non-Volatile (No backup battery required)
- >10 years data retention.

Enclosure Sealing

- Integral Probe IP67
- Remote Electronics IP65 (Nema 4x)
- Remote Probe IP67.

Cable Entries

BSP process mounting

- 2 x M20 Glands.

NPT process mounting

- 2 x 3/4" NPTF threaded adaptors.

Remote

- 3 x 20mm (0.8"), 1 x 16mm (0.6") knock outs.

Mounting

- 1/2" NPT or BSP Thread
- 3/4" NPT or BSP Thread
- 1" NPT or BSP Thread
- 1.5" NPT or BSP Thread
- 50mm (2") Flange (ANSI, DIN or JIS patterns available).

Remote Test Input

Press to test (used to check for malfunction of unit from remote position, PLC, SCADA etc).

Dielectric Constants Table

Please see www.hawkmeasure.com or consult the Gladiator manual.



HAWK, Since 1988

Hawk Measurement Systems Pty Ltd (HAWK) was established in 1988. It's founding members saw the universal requirement of various industries requiring improved process control and efficiency in their operations.

We Can Help

HAWK understands the difficulties customers face when seeking accurate level measurement. Every application is different, involving a multitude of environmental factors. This is where HAWK excels. Our aim is to ensure that customers feel comfortable with our technology, and are provided with long term and reliable solutions. We believe that a combination of application and product expertise, as well as forward thinking and proactive support policies are the foundation of successful customer-supplier relationships.

Progressive Technical Support

HAWK believes that the future of the Level Measurement Industry revolves around the quality of pre and post sales - support. Our aim is for all sales & support staff to be product experts, and more importantly application experts making our customers applications as efficient and consistent as possible.

Knowledge Sharing

HAWK believes that knowledge sharing is key to creating long term relationships. Empowering our customers and our worldwide distribution network, whilst being available at all times to lend a helping hand, is the perfect recipe for long term solutions and relationships. HAWK openly extends an invitation to share our 25 years of level measurement experience, and ensure that your day to day processes are efficient, understood, and always working.

Hawk Measurement Systems (Head Office)

15 - 17 Maurice Court
Nunawading VIC 3131, Australia
Phone: +61 3 9873 4750
Fax: +61 3 9873 4538
info@hawk.com.au

Hawk Measurement

96 Glenn Street
Lawrence, MA 01843, USA
Phone: +1 888 HAWKLEVEL (1-888-429-5538)
Phone: +1 978 304 3000
Fax: +1 978 304 1462
info@hawkmeasure.com

Represented by:

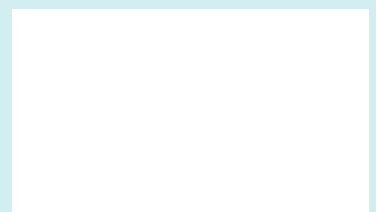

For more information and global representatives: www.hawkmeasure.com

Additional product warranty and application guarantees upon request.
Technical data subject to change without notice.