



BLS Level Sensor

- **for many applications**
- **easy to use**
- **easy to install**
- **maintenance free**

BLS Level Sensor – smart and innovative



The BLS Level Sensor, an innovative product for level detection and monitoring.

- One sensor detects different media (liquids, bulk goods, foams: sticky, pasty or high or low viscosity)
- Maximum temperature stability and repeat accuracy
- Resistant to shocks and vibrations
- Response time < 100 ms
- Fully integrated electronics
- Maintenance free
- Small and good looking design
- LED switching point indicator
- Factory setting for DK (€) ≥ 2.5



One sensor for many applications in different industries:

- Pharmaceutical
- Laboratory
- Food & beverage
- Watermanagement
- Railway and vehicle construction
- Machinery and apparatus engineering
- Plant construction
- Chemical and petrochemical industry
- Shipbuilding



BLS Level Sensor – technical data



Type	BLS 10	BLS 11	BLS 20	BLS 30 ¹⁾
Process connection	G 1/2"	G 1/2"	G 1/2"	G 1/2"
Process temperature	-40 to +115 °C	-40 to +115 °C	-40 to +85 °C	-40 to +115 °C
Ambient temperature	-40 to +85 °C	-40 to +85 °C	-40 to +70 °C	-40 to +85 °C
Max. process pressure	100 bar	100 bar	100 bar	100 bar
Electrical connection	Connector M12	Connector M12	Cable 5 m	Connector M12
Power supply	12...30 VDC, 35 mA max.	12...30 VDC, 35 mA max.	12...30 VDC, 35 mA max.	12...30 VDC, 35 mA max.
Enclosure	IP67	IP67	IP67	IP67
Output configuration	PNP	PNP	PNP	PNP
Housing material	1.4404 / AISI 316L	1.4301 / AISI 304	1.4404 / AISI 316L	1.4404 / AISI 316L
DNV Approval	x	x	x	x
ATEX Approval				Ex ia IIC T5, ATEX II 1G (Gas)

¹⁾ Isolation module on demand

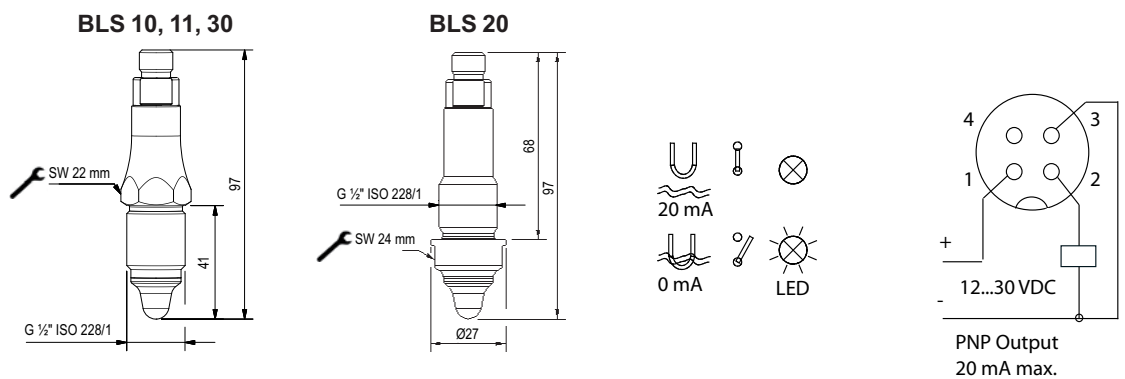

The tip of the sensor is made of PEEK plastic. The sensor works on the principle of frequency-sweep technology. The sensor output can be switched from digital to pulse width modulation (PWM). The sensor recognizes different media and can therefore be used for media separation. The analysis of the PWM signal must be done in the connected control unit (PLC).

BLS Level Sensor

Typical applications

- Level detection for storage tanks, containers and pipelines.
- Detection of different media.
- Protecting pumps from running dry.

BLS Level Sensor for DK-values (ϵ) ≥ 2.5
i.e. for almost all liquids ok, but also for
bulk goods, foams, sticky, pasty or high or
low viscosity.

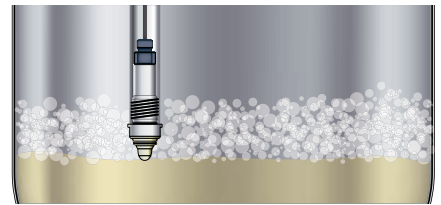
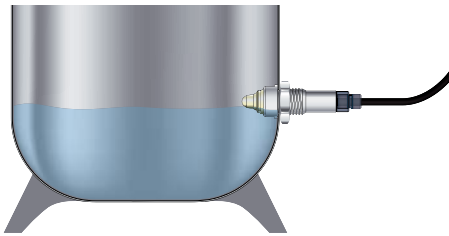

Pharmaceutical / Laboratory:

- Liquids
- Cream and paste
- Powder
- Granules
- Pills

Food and beverage industry:

- Water
- Milk products
- Beer
- Yogurt
- Coffee beans
- Liquid chocolate
- Edible oil
- Sauces

Industry / Petrochemical:

- Water
- Waste water
- Oil
- Ammonia
- Methanol

Approvals

- ATEX
- DNV Marine Approval
- FDA (on demand)



BACHOFEN
Industrial Automation

Bachofen AG

Ackerstrasse 42, CH-8610 Uster, Switzerland
Phone +41 44 944 11 11, info@trimod.ch, www.trimod.ch

LBXEN201510

Your BLS distributor

www.trimod.ch